

Atwood® Surge Brake Actuators

PROTOW®

Unique Design for Superior Braking

- Unique design creates more pressure at the brakes than in-line actuator systems.
- Parts interchangeability between 6K and 8K actuators. No need to stock additional parts for two sizes of actuators.
- Lock-out feature allows use with standard hydraulic brakes for backing up. No need for specific free-backing brakes.
- Disc brake actuators available specifically for use with disc brake systems. Supplies even more fluid pressure to brakes than standard hydraulic.
- Breakaway device will set trailer brakes automatically should separation from tow ball occur.
- 2 year limited warranty.

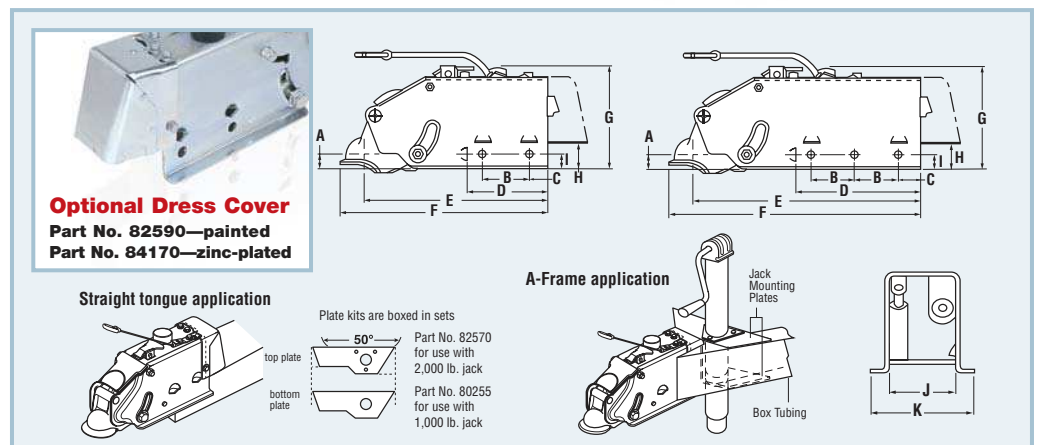

Surge Brake Actuator Selection Guide

Part No.	Description	Rated Capacity lbs.	Class	Tongue Load (max.)		A	B	C	D	E	F	G	H	I	J	K
82543	2" ball, painted	6,000	S.A.E. 4	900 lbs.	in.	7/8	3	1 1/8	5 1/8	11 9/16	13 3/16	6 5/8	11 1/16	1 1/16	3 1/16	4 5/8
					mm	22	76	29	130	294	335	168	43	17	78	117
83153*	2" ball, painted, zinc plated latch	6,000	S.A.E. 4	900 lbs.	in.	7/8	3	1 1/8	5 1/8	11 9/16	13 3/16	6 5/8	11 1/16	1 1/16	3 1/16	4 5/8
					mm	22	76	29	130	294	335	168	43	17	78	117
84132	2" ball, zinc plated	6,000	S.A.E. 4	900 lbs.	in.	7/8	3	1 1/8	5 1/8	11 9/16	13 3/16	6 5/8	11 1/16	1 1/16	3 1/16	4 5/8
					mm	22	76	29	130	294	335	168	43	17	78	117
84133*	2" ball, zinc plated, zinc plated latch	6,000	S.A.E. 4	900 lbs.	in.	7/8	3	1 1/8	5 1/8	11 9/16	13 3/16	6 5/8	11 1/16	1 1/16	3 1/16	4 5/8
					mm	22	76	29	130	294	335	168	43	17	78	117
88730	2" ball, zinc plated* for Disc Brakes	6,000	S.A.E. 4	900 lbs.	in.	7/8	3	1 1/8	5 1/8	11 9/16	13 3/16	6 5/8	11 1/16	1 1/16	3 1/16	4 5/8
					mm	22	76	29	130	294	335	168	43	17	78	117
88740	2" ball, painted for Disc Brakes	6,000	S.A.E. 4	900 lbs.	in.	7/8	3	1 1/8	5 1/8	11 9/16	13 3/16	6 5/8	11 1/16	1 1/16	3 1/16	4 5/8
					mm	22	76	29	130	294	335	168	43	17	78	117
83000	2" ball, painted, weld-on only	8,000	S.A.E. 4	1,000 lbs.	in.	7/8	3	1 1/8	8 1/8	14 9/16	16 3/16	6 5/8	11 1/16	—	3 1/16	4 5/8
					mm	22	76	29	206	370	411	168	43	—	78	117
83005	2" ball, painted, bolt-on	8,000	S.A.E. 4	1,000 lbs.	in.	7/8	3	1 1/8	8 1/8	14 9/16	16 3/16	6 3/4	11 13/16	1 1/16	3 1/16	4 5/8
					mm	22	76	29	206	370	411	171	46	17	78	117
83010	2" ball, zinc-plated, bolt-on	8,000	S.A.E. 4	1,000 lbs.	in.	7/8	3	1 1/8	8 1/8	14 9/16	16 3/16	6 3/4	11 13/16	1 1/16	3 1/16	4 5/8
					mm	22	76	29	206	370	411	171	46	17	78	117
80366	2" ball, zinc plated* bolt-on for disc brakes	8,000	S.A.E. 4	1,000 lbs.	in.	7/8	3	1 1/8	8 1/8	14 9/16	16 3/16	6 5/8	11 1/16	—	3 1/16	4 5/8
					mm	22	76	29	206	370	411	168	43	—	78	117
80360	2" ball, painted*, weld-on for disc brakes	8,000	S.A.E. 4	1,000 lbs.	in.	7/8	3	1 1/8	8 1/8	14 9/16	16 3/16	6 5/8	11 1/16	—	3 1/16	4 5/8
					mm	22	76	29	206	370	411	168	43	—	78	117

* Bulk pack — all others are in individual cartons. **8,000 lb. weld on actuators do not have holes for bolt attachment (weld on ONLY).

* Compatible with Kodiak® and Reliable® Disc Brake Systems