

Installation Instructions

LT37 Hand Tool Rack for Enclosed Landscape Trailers

Important!

Before you begin installing:

1. Read and understand these instructions completely.
2. Verify that you have received all the parts listed in the bill of materials.

CAUTION:

Always wear safety glasses when using power tools.

Tools and Materials Required:

- 1/2" Wrench or Socket
- Electric Drill
- 7/32" Drill Bit
- 3/4" Plywood Shim Strips
- Shim Screws

1. Locate a suitable place on the wall to mount the hand tool rack. The two racks should be mounted 32" apart on a 7°-10° angle such that the tools (when removed) extend upward out of the rear door of the trailer. It is recommended that you verify that there is enough space to accept the tool with the largest head (typically the leaf rake).

2. In order to mount this rack to the enclosed trailer, **you must first add 3/4" plywood shim strips to the walls.** These shim strips must be attached to at least two wall support studs with suitable fasteners. If you don't know what kind or length of fastener to use contact your trailer dealer or manufacturer for their recommendation.

3. After laying out the position of the rack and mounting the shims, hold the hand tool racks against the shims and mark the position of the four 5/16" holes in each rack. Make sure that the two racks are parallel with each other and are at the proper spacing. To verify that the racks are parallel, make sure that the distance between the racks on both ends is 32". It may be necessary to lightly tack one or both racks to the shims to determine the final positions.

WARNING! Check for locations of brake lines and electrical wiring etc., before drilling any holes. Any damage to trailer during installation is the installer's sole responsibility.

4. Drill eight 7/32" pilot holes in the positions just marked for the 5/16" lag screws. **Be extremely careful not to drill through the outside trailer wall.**

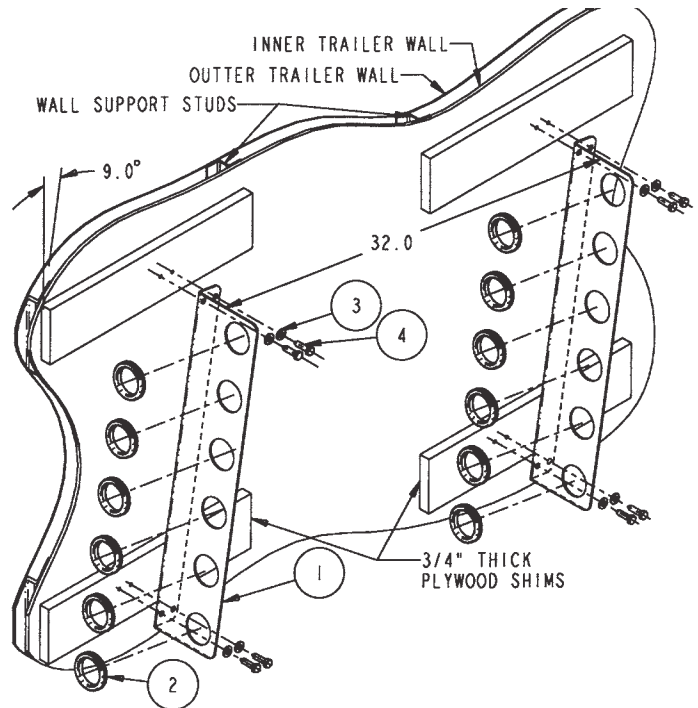

Bill of Materials

ITEM	PART NO.	QTY.	DESCRIPTION
1	3004448	2	Angle, Tool Holder
2	3004167	12	Grommet, Rubber, for 2" hole
3	-	8	Washer, 5/16 SAE Zn
4	-	8	Screw, Hex Head Lag, 5/16 x 1-1/4 Zn

5. Fasten the racks to the trailer wall with the eight 3/8" x 1-1/4" lag screws and eight 3/8" flat washers supplied.

6. Assemble the twelve grommets into the six 2" holes in each bracket.

Warranty Information

Buyers Products Co. warrants all truck/trailer hardware manufactured or distributed by it, to be free from defects in material and workmanship for a period of one year from date of shipment. Parts must be properly installed and used under normal conditions. Any product which has been altered, including modification, misuse, accident or lack of maintenance will not be considered under warranty. Normal wear is excluded. The sole responsibility of Buyers Products Co. under this warranty is limited to repairing or replacing any part or parts which are returned, prepaid, and are found to be defective by Buyers Products Co. Authorization from Buyers Products Co. must be obtained before returning any part. No charges for transportation or labor performed on Buyers' products will be allowed under this warranty.