

Operating Instructions:

1. Before operating, inspect hitch assembly for proper operation and worn, damaged, or missing parts. Correct any flaws before use.
2. Verify that the plunger is retracted. Release air pressure to retract plunger if necessary.
3. Remove safety pin, lift toggle, and rotate jaw to opened position.
4. Lower drawbar eye over the horn of the pintle.
5. Pull jaw downward until toggle seats and insert safety pin. Verify latch does not open by lifting upwards on jaw.

WARNING

Other steps and inspections are also required. Consult DOT regulations and American Trucking Association for complete coupling and uncoupling procedures.

Maintenance:

1. Clean and check for proper operation.
2. Inspect and replace worn, damaged, or missing parts. Replace worn parts after the wear exceeds 1/8" from the original surface.
3. Keep all pivot points well lubricated with light oil.
4. Check mounting bolts for proper torque.
5. Check for proper plunger adjustment. See step 8 under mounting instructions.

General Information:

1. Do not modify or add to the product.
2. Wear safety glasses during the installation, removal and servicing of the hitch.
3. Never strike any part of this hitch with a steel hammer.
4. Do not weld on this product.

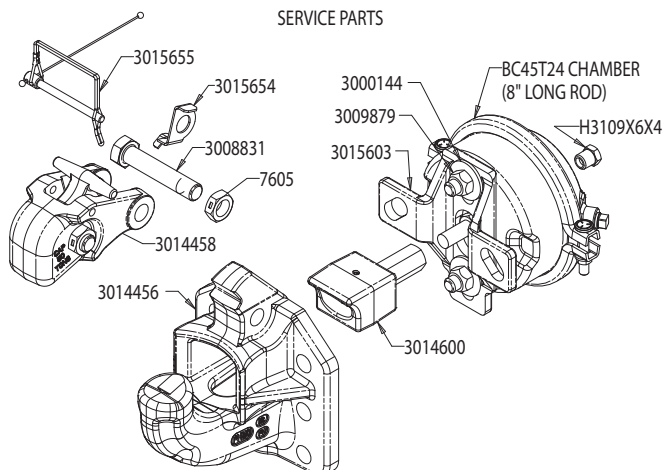
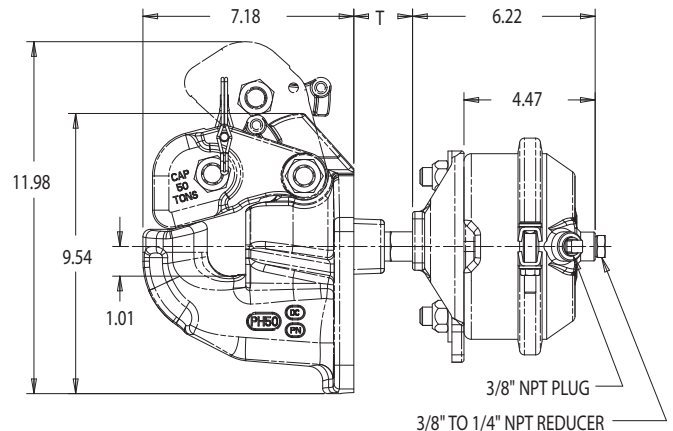
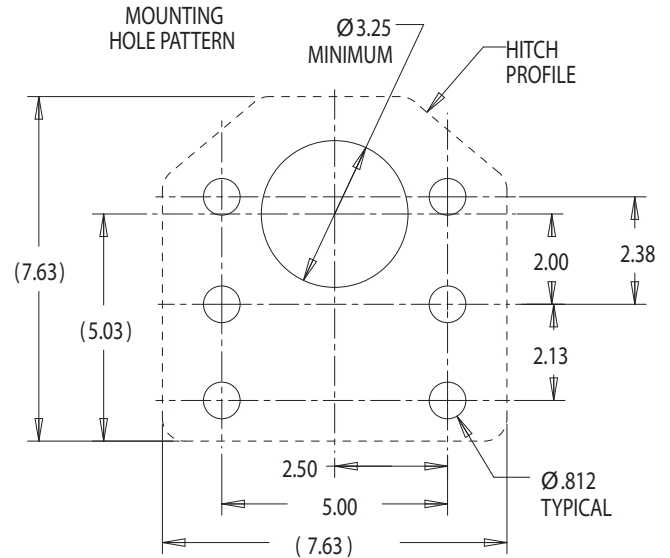

Warranty

Buyers Products Co. warrants all truck/trailer hardware manufactured or distributed by it, to be free from defects in material and workmanship for a period of one year from date of shipment. Parts must be properly installed and used under normal conditions. Any product which has been altered, including modification, misuse, accident or lack of maintenance will not be considered under warranty. Normal wear is excluded. The sole responsibility of Buyers Products Co. under this warranty is limited to repairing or replacing any part or parts which are returned, prepaid, and are found to be defective by Buyers Products Co. Authorization from Buyers Products Co. must be obtained before returning any part. No charges for transportation or labor performed on Buyers' products will be allowed under this warranty.

Installation Instructions

PH50/PH50AC 50-Ton Pintle Hooks

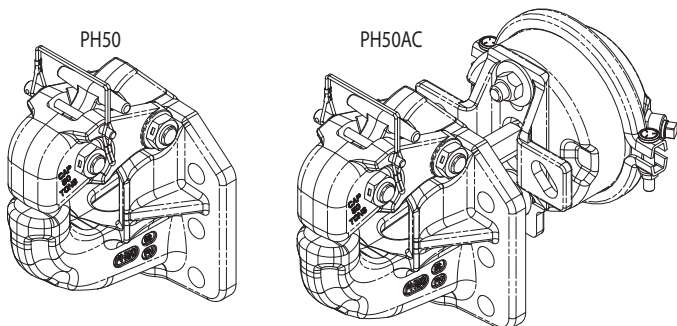

Capacity

100,000 lbs. Maximum Gross Trailer Weight
 20,000 lbs. Maximum Vertical Load

Description:

Rigid type pintle hook with air actuated plunger (recommended). The plunger provides minimum clearance with some shock absorption. This pintle hook can be utilized with or without the air chamber and plunger.

WARNING

Maintain adequate vertical (tongue) load to properly control the trailer (generally 10%) but do not exceed the above rated capacities.

Towing Applications:

Trailers, full trailers, doubles, and triples operating within the stated capacities. Reduce capacities by 25% for off road applications and use with swivel type trailer drawbar.

Drawbar Eye Dimensions:

2-3/8" to 3" inside diameter with 1-1/4" to 1-5/8" diameter cross-section

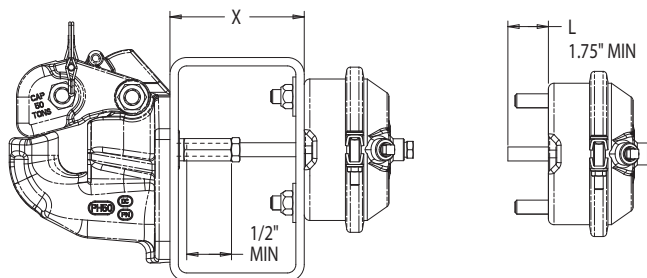

Mounting Instructions:

For installations without an air chamber, use steps 1, 2, & 6 below.

- 1.** Use mounting structure of sufficient strength to support the rated capacity of the pintle hook in accordance with SAE J849 (Type II).
- 2.** Use the hole pattern dimensions shown. See mounting hole pattern drawing.
- 3.** Determine the cut length for the air chamber rod and cut rod to length (steps 3a or 3b). Before cutting the rod, assemble jam nut past the determined cut point and remove after cutting to clean up the threads. Do not cut chamber rod any shorter than 1.75".
 - 3a.** If the mounting configuration uses the supplied chamber mount bracket: Cut length (L) = mounting plate thickness (T) + 1.00
 - 3b.** If the mounting configuration does not utilize the chamber mount bracket: Cut length (L) = total mounting thickness (X) - 0.75
- 4.** Assemble air chamber to mount bracket or custom mounting structure. Torque fasteners to 133-155 ft-lbs.
- 5.** Assemble jam nut and plunger to the air chamber's rod. The plunger should be threaded onto the end of the rod with approximately 1.5" of engagement.
- 6.** Install pintle hook assembly using six new 3/4" grade 8 bolts. Torque fasteners to a minimum torque of 200 ft-lbs. Do not exceed the bolt manufacturer's recommended torque.
- 7.** Connect the air supply. Refer to vehicle manufacture for their recommendations for an air source, plumbing, and pressure protection.
- 8.** Check the plunger adjustment. The plunger should extend enough to clamp on a 1-1/4" drawbar and retract enough to easily remove 1-5/8" drawbar. To adjust the plunger, loosen the jam nut on the chamber rod and tighten or loosen the plunger to increase or decrease the amount of extension and re-tighten the jam nut after the adjustment is completed. The plunger must be threaded onto the chamber rod a minimum of 1/2" after the adjustments have been made.

WARNING

Do not damage latch. Be careful with the drawbar when coupling or uncoupling hitch.