

Electric Fuel Sender

YOUR MOELLER PROMISE: Every unit has been pre-inspected to guarantee full range of calibrated readings and designed for gaso-line applications. You can also use diesel if separate return line is available. **DO NOT USE WITH WATER.** For your safety and for best results, pre-read the following instructions completely before installation. We, at Moeller Marine, thank you for your purchase!

BEFORE YOU INSTALL:

- **Replace an existing unit** by removing the old unit noting the direction of movement of the float arm. This assures clearance with tank wall.
- **Position new unit above tank**, aligning it with screw hole pattern in the mounting plate with hole pattern in top of tank. Observe the direction of movement of float arm. If arm position causes it to hit wall, you must rotate the sending unit (see next step.) If arm moves freely, proceed to "NEED TO ADJUST BRACKET" or "NEED TO ADJUST FLOAT ARM LENGTH."
- **Rotate the sending unit** by loosening nut at top of sending unit just enough to enable the mounting plate to be raised approximately 1/8" (3.25 mm) to clear the square. This allows you to turn screw assembly in 90° increments (see Diagram 1.) Turn until the float arm is situated to clear the tank wall freely.
- **Tighten screw at top** of sending unit to 15"lb. using a torque wrench.

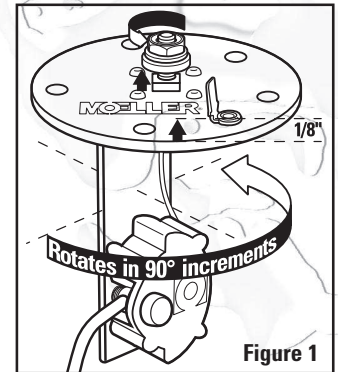

Figure 1

NEED TO ADJUST BRACKET?

- **Decide tank depth** by measuring from inside bottom to outside top of tank. Measure from underside of mounting plate along bracket. Mark bracket at half tank depth plus 1/2" (13mm) and use a hacksaw to cut bracket.
- **Position float arm case on bracket** 1/4" (6.5mm) from bottom of bracket and secure with two self-tap screws. NOTE: MAKE SURE YOU PUT WIRE BETWEEN CASE AND BRACKET.

NEED TO ADJUST FLOAT ARM LENGTH?

- **See Diagram 1.** Use measured tank depth dimension (if exact tank depth is not listed, use next highest depth) then locate float arm length.
- **Slide float and push-on fasteners** toward case until outer end of float is 5/16" (8mm) less than float arm dimension.
- **Cut arm** at float arm dimension.

| Diagram 1 Tank Depth | | Float Arm Length | |
|-------------------------|-----|---------------------|-----|
| Inches | MM | Inches | MM |
| 6 | 152 | 4 | 102 |
| 6-1/2 | 165 | 4-1/2 | 114 |
| 7 | 179 | 5 | 127 |
| 7-1/2 | 191 | 5-13/16 | 148 |
| 8 | 203 | 6-5/16 | 160 |
| 8-1/2 | 216 | 6-13/16 | 173 |
| 9 | 229 | 7-5/16 | 186 |
| 9-1/2 | 241 | 7-13/16 | 198 |
| 10 | 254 | 8-5/16 | 211 |
| 10-1/2 | 267 | 8-13/16 | 224 |
| 11 | 279 | 9-5/16 | 237 |
| 11-1/2 | 292 | 9-13/16 | 249 |
| 12 | 305 | 10-5/16 | 262 |

ADJUST FLOAT ARM LENGTH:

1. Use measured tank depth dimension and locate float arm length (see Diagram 1.)
2. Slide float and push-on fasteners toward case until outer end of float is 5/16" (8mm) less than float arm dimension.
3. **IMPORTANT:** Keep 1/16" (1.75mm) space between float and inner fastener.
4. Cut float arm at float arm dimension.

PROPER SENDING UNIT TANK INSTALLATION:

5. Carefully slide gasket over float arm and sending unit to fit flat against underside of mounting plate. Now you're ready to install completed unit into tank by carefully inserting first the float arm, and then the sending unit through the tank hole. **DO NOT BEND THE FLOAT ARM. THIS COULD CAUSE THE SENDING UNIT TO MALFUNCTION.**
6. Align gasket properly with the mounting plate and tank. NOTE: The gasket's 5-hole screw pattern only fits one way (see Figure 2.)
7. Tighten screws just until white sealant shows beneath the screw head. **DO NOT OVER-TIGHTEN. THIS WEAKENS THE SEAL.**

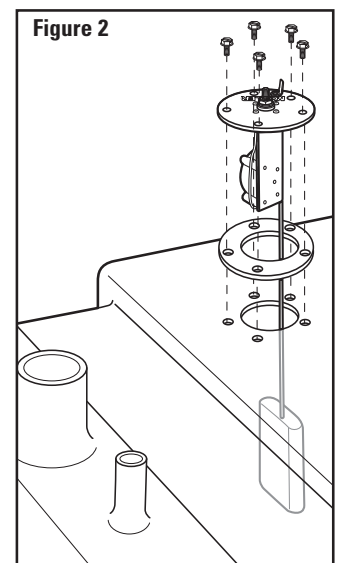

Figure 2

Electric Fuel Sender

8. For a **NO LEAK install**, a leak test of this area should be conducted by pressurizing the tank to 3 PSI. Then look for bubbles using soapy water. (See Figure 3) **IMPORTANT: IF UNSURE OF THIS OR ANY OF THE DETAILED PROCEDURES, SEEK PROFESSIONAL ASSISTANCE.**

⚠ WARNING Seek professional assistance if unsure of electrical wiring connections or any of the above instructions. **GASOLINE IS EXTREMELY FLAMMABLE. KEEP TANK AREA FREE FROM SPARKS AND FLAMES. EMPTY TANK OF FUEL AND FUMES BEFORE CONTINUING WITH INSTALLATION.**

PROPER WIRING INSTALLATION:

1. **Connect sender(s)** wire from fuel gauge to the threaded terminal on sender.
2. **Connect ground** wire to 1/4" fasson terminal on sender.

