



INSTALLATION AND OPERATION MANUAL

SHURflo's Pro Baitmaster pumps are designed to handle the harsh marine environment. The motor is protected by an integral thermal breaker, and is U/L Marine listed. Baitmaster pressure switches are sealed and the motors are finished with Electro-coating to inhibit corrosion. A Baitmaster pump can be mounted in an environment where "splashed water" may be present. The Baitmaster pumps are enclosed to prevent incidental moisture from entering; however, they **are not submersible**. The Baitmaster delivers water on demand. With the output side closed (valve off) the pump will turn off. As the valve is opened the pressure within the output side drops. Once the pressure drops below a predetermined point the pressure switch closes and the pump turns on. If the output side is wide open the pump operates continuously. When the valve is partially opened the pump may cycle ON/OFF (intermittent duty) as it is able to pressurize faster than the water is being released.

MOUNTING

1. Consider a dry location that allows easy access if maintenance is required. The pump should not be located in an area of less than one cubic foot unless adequate ventilation is provided. Excessive heat may trigger the integral thermal breaker and interrupt operation. When the temperature drops the breaker will automatically reset and the pump will start.
2. Mount higher than the outside water (sea) level. The pump is capable of 6 ft. [1.82M] vertical prime above the outside water level. The pump can be mounted in any position. If mounting the pump vertically, the pump head should be in the down position.

TYPICAL INSTALLATION

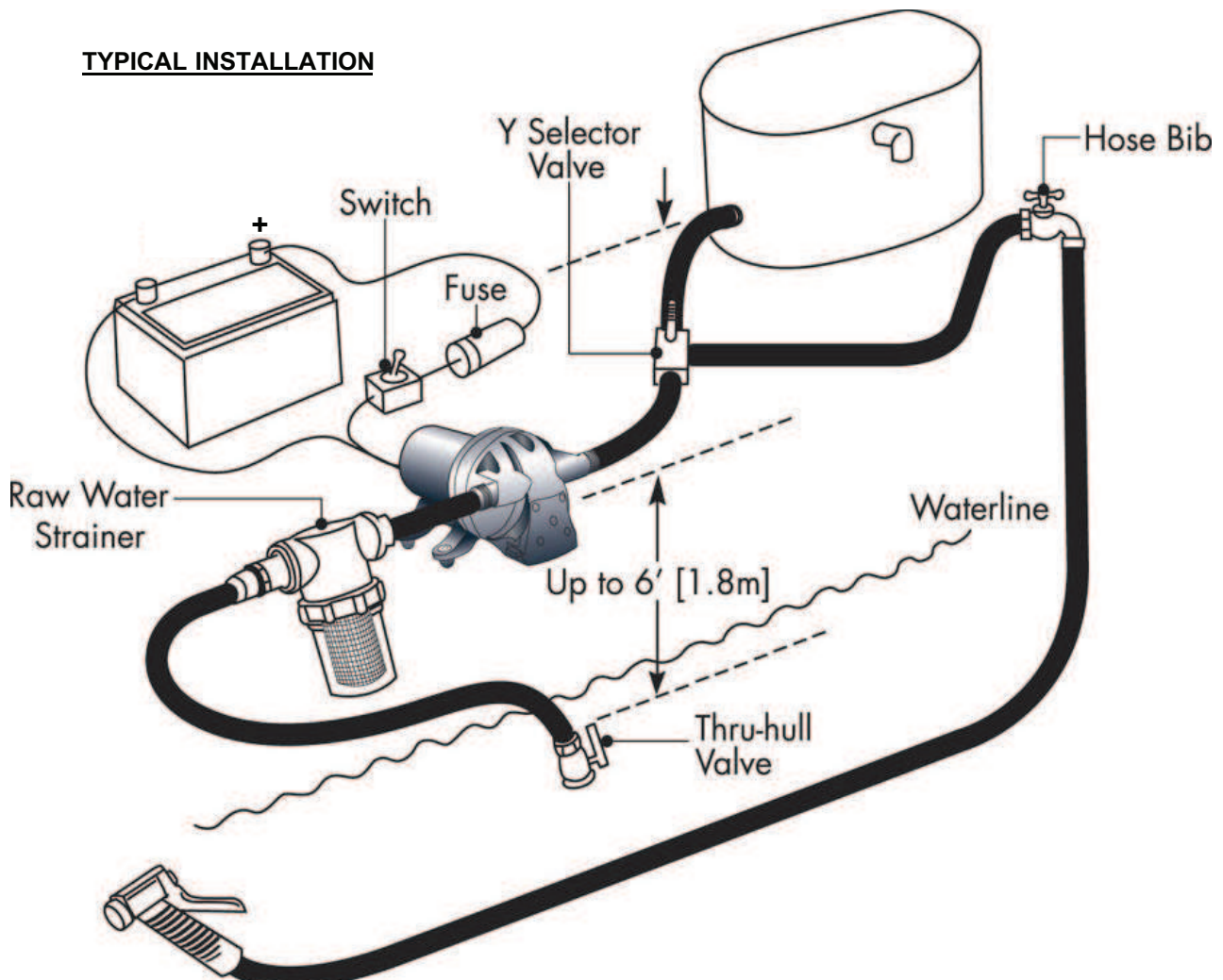

CAUTION: *Do not* drive screws through the vessel's hull.

3. The pump baseplate should be fastened to a **solid** surface (bulkhead or stringer) that will not amplify pump operation. The mounting pads are intended to isolate the pump from the mounting surface. Over tightening, flattening, or use of screws will reduce the mounting pads ability to isolate vibration/noise.

DUTY CYCLE

Bait Tank Applications: The pump is rated for "continuous duty" (no ON/OFF cycling), when operated at open flow (less than 10 psi. [.7 bar] backpressure).

CAUTION:

The motor may become hot when operated continuously. **DO NOT** locate near low temperature plastics or combustible material.

Wash-down Applications: If used for wash-down, the pump is rated for "intermittent duty", because it operates at higher average amperage and outlet pressures. Operating a pump in a wash-down application for more than twenty (20) minutes, within an hour, is not recommended. Actual duty cycle is determined by amp draw, temperature, and rate of cycling. **NOTE:** Rapid cycling should be minimized to ensure long life. Rapid cycling is defined as ON/OFF within two seconds.

BAIT TANK CRITERIA

There are many factors that must be considered to assure the correct operation of a bait or live well system. The pump is one part of the selection. Keeping the bait healthy is dependent upon; the amount of water in relation to the quantity of bait, flow pattern, water renewal/changes, and water temperature. SHURflo Baitmaster pumps are generally suited for livewells that have a water capacity of 20 to 35 gallons [75-132 L]. Ideally, the tank should be oblong in shape. Currents within the tank should be kept in a slow, smooth, C.C.W. circulating pattern. The bait should swim freely, and not become overworked or exhausted in swift currents or turbulence. The bait will become stressed, or not receive enough oxygen if water flow/currents are incorrect. Bait is generally kept very active and healthy within cooler water temperatures (up to the mid-60's°F[15°C]). As the temperature approaches 70°F[21°C] the water must be renewed (water changes) more often to keep the bait active and healthy. The pump should be selected based on its open flow specification. Allowing the pump to run at open flow will permit continuous low amp draw operation. A pump is correct for a particular live well if its open flow G.P.M. fills or renews within a six to ten-minute period. (Actual live well gallons divided by open flow specification) If the water temperatures are normally in the low to mid 60°F [15°C] range, water should be renewed closer to the ten-minute time span. Although, if used primarily in warm water, a pump capable of renewing the tank more often (6 min.), should be selected.

ELECTRICAL

- An ignition protected switch (U/L approved marine duty) rated at or above 15 amps is recommended and must interrupt current on the positive (+ red) lead.

CAUTION: Use of "open" type switches (not ignition protected) may cause an explosion of fuel vapors.

- The pump should be on a dedicated (individual) circuit protected on the positive (+ red) lead with the proper size "slow blow" fuse. The fuse rating indicated by the motor label is intended for "intermittent duty" applications. For bait tank applications (continuous duty/open flow) fuse rating may be 30% less than the indicated fuse rating due to lower operating amperage. The total current draw on the circuit **must not** exceed 15 amps.
- Wire size (gauge/mm²) is based on the distance from the power source to the pump. The minimum recommended wire size is #14 gauge [2.5 mm²]. For lengths of 20-50 ft. [6-15M] use #12 gauge [4 mm²] or larger. The pump must be grounded to a "known ground" (battery). The ground wire must be the same size as the positive wire.

PLUMBING

- SHURflo swivel hex/barb fittings provide easy removal if maintenance or access is required. The fittings are designed with a "taper-seal", creating a water tight connection when **hand-tightened** ¼ turn after contact. Always secure barb tubing connections with properly sized stainless steel clamps to prevent leaks. For connecting to the pumps 1/2" threaded ports SHURflo supplies taper-seal swivel-barb fittings for various tubing sizes.

* Included with retail Baitmaster pump kits

- Inlet tubing (1/2" I.D. min.) from the sea-cock valve to the pump should be rated for vacuum. If rigid tubing or pipe is utilized, SHURflo recommends the inlet port be plumbed with a minimum of 1 ft.[.3M] of flexible vacuum rated tubing. Standard garden hose is not suitable as inlet tubing as it may collapse under vacuum, reducing water flow.
- The pump outlet port **should not** be connected to rigid (plastic) pipe. Normal oscillation of the pump may transmit through rigid plumbing causing noise and possibly loosen or crack components. A minimum of 1 ft.[.3M] length of flexible high pressure tubing is suggested. Avoid any sharp radius in tubing that may kink over time. Route tubing away from any heat (exhaust manifolds etc.) and fasten securely.

RAW WATER STRAINER

A bait system is only as dependable as the water available to pump. A strainer with adequate capacity to trap debris **must** be part of the system. Using #50 mesh or larger provides sufficient capacity under most conditions. The interval for cleaning will be determined by the amount of debris encountered. Check the strainer before and after each use. **Failure due to debris in the pump will not be covered under warranty.**

CAUTION:

The strainer **must** be mounted above the outside water line to prevent water from siphoning during cleaning, without closing the sea-cock valve. Mount the strainer where it can be inspected and cleaned easily.

NOTES & CAUTIONS

- To prevent cavitation, through hull fittings should be located at least 12 in. off the center line of the water pick-up for the motor.
- The through hull fitting should have a sea-cock valve to shut-off in case of an emergency.
- Double clamp all tubing connections that are below the water line.
- Always use high quality non-corrosive fittings, valves, and hardware to assure long term reliability.
- Electrical connections should be soldered and insulated to prevent shorts and corrosion. Wiring should be routed away from areas prone to water, excess moisture, and heat. Properly seal all pipe threads before the strainer to prevent unforeseen leaks. **Never** use Teflon tape or sealing compounds on pump threads. Sealer may enter the pump causing a failure not covered under warranty.

WINTERIZING

If water is allowed to freeze in the system, serious damage to the plumbing and pump may occur. Failures of this type will void the warranty. The best guarantee against damage is to completely drain the system as follows:

1. Turn power OFF to the pump. Close the sea-cock valve at the through-hull fitting. All water in the inlet tubing should be drained.
2. Remove both inlet/outlet port connections at the pump and drain the tubing.
3. Turn the pump ON and allow water inside the pump to be purged.
It is recommended that the pump's inlet/outlet port not be reconnected.
4. Make a note at both the sea-cock valve and bait tank that the "Plumbing is Disconnected".

GENERAL SAFETY PRECAUTIONS

- When the vessel is not in use, the main power switch and sea-cock valves should be OFF. However, if left afloat the bilge pump should still have power. Never operate the engine or electrical equipment if fuel vapor is detected until the source is located and/or properly vented.

TROUBLESHOOTING

Vibration induced by sea conditions or transporting may cause plumbing or pump hardware to loosen. Check for system components that are loose. Many symptoms could be resolved by simply tightening. Check the following items along with other particulars of the system.

PUMP WILL NOT START/ BLOWS CIRCUIT:

- ✓ Is the motor hot? Thermal breaker may have triggered; it will reset when cool.
- ✓ Electrical connections, fuse, main switch, and ground. (corrosion)
- ✓ Is voltage present at the switch? Bypass the pressure switch. Does the pump operate?
- ✓ Charging System for voltage ($\pm 10\%$) and good ground.
- ✓ For improper fuse rating or wire size.
- ✓ For an open or grounded circuit, or motor.
- ✓ For seized or locked drive/diaphragm assembly.

WILL NOT PRIME/SPUTTERS: (No discharge/Motor runs)

- ✓ Is the strainer clogged with debris?
- ✓ Is there debris in the through hull fitting?
- ✓ Is the inlet plumbing sucking in air at tubing connections (vacuum leak)?
- ✓ Is inlet/outlet plumbing severely restricted or kinked?
- ✓ Proper voltage with the pump operating ($\pm 10\%$).
- ✓ For debris in pump inlet/outlet valves or swollen/dry valves.
- ✓ Pump housing for cracks or loose drive assembly screws.

PUMP WILL NOT SHUT-OFF / RUNS WHEN NOZZLE IS CLOSED:

- ✓ Output side (pressure) plumbing for leaks.
- ✓ For air trapped in outlet side or pump head.
- ✓ For correct voltage to pump ($\pm 10\%$).
- ✓ For loose drive assembly or pump head screws.
- ✓ Is the internal check valve held open? Are the valves swollen or held open by debris?
- ✓ Pressure switch operation/adjustment incorrect.

NOISY OR ROUGH OPERATION:

- ✓ For plumbing which may have vibrated loose.
- ✓ Is the pump plumbed with rigid pipe causing noise to transmit?
- ✓ Does the mounting surface multiply noise (flexible)?
- ✓ For mounting feet that are loose or compressed too tight.
- ✓ For loose pump head or drive screws.
- ✓ The motor with pump head removed (3 long screws). Is noise from motor or pump head?

LEAKS FROM PUMP HEAD OR SWITCH:

- ✓ For loose screws at switch or pump head.
- ✓ Switch diaphragm ruptured or pinched.
- ✓ For punctured diaphragm if water is present in drive assembly.
- ✓ Check for damaged pump head (cracked).

HEX-WING FITTINGS AVAILABLE

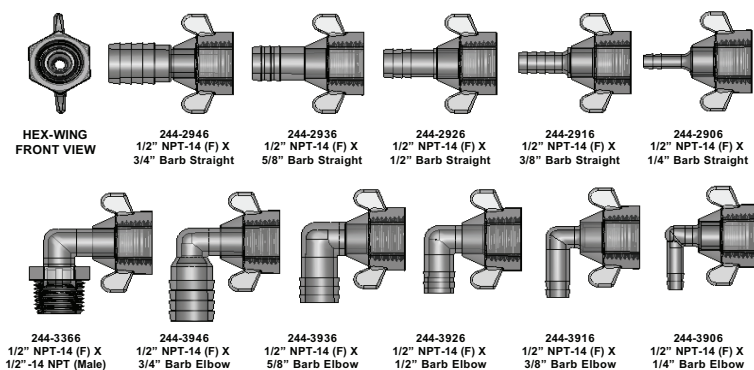

SERVICE KITS

- 1. Pressure Switch 94-668-00
- 3. Valve Assembly 94-669-00
- 4. Drive Assembly 94-670-00
- 2. Upper Housing 94-670-01
- 5. Motor 12V DC 77-025-17
- 6. Motor 24V DC 77-026-17

Raw Water Strainers Available

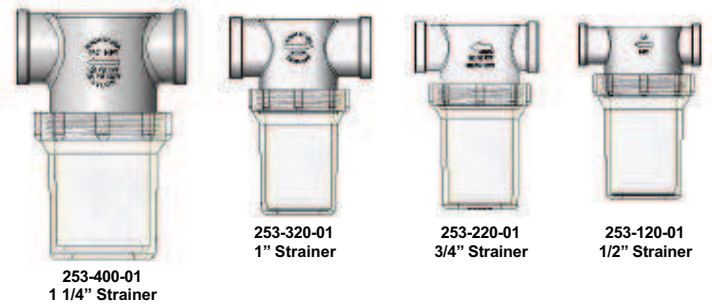
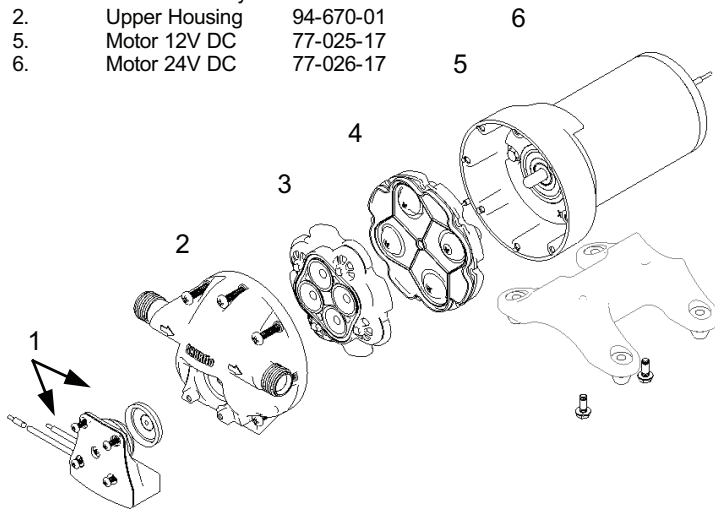

LIMITED WARRANTY

SHURflo warrants The Pro Baitmaster series pump to be free from material and workmanship defects under normal use and service for a period of (2) two years from the date of purchase. In the absence of proof of purchase the warranty is (2) two years from the date of manufacture indicated on the motor nameplate, not to exceed two years in any event. Pumps used in commercial applications are warranted for three (3) months from date of purchase only (proof required). The limited warranty will not apply to pumps that were improperly installed, misapplied, or incompatible with components not manufactured by SHURflo. Pump failure due to foreign debris is not covered under the terms of this limited warranty. SHURflo will not warrant any pump that is physically damaged, or altered outside the SHURflo factory. Warranty claims may be resolved by an authorized dealer service center, or by a SHURflo service center. All returns are to be shipped with charges pre-paid. Package all returns carefully. SHURflo will not be responsible for freight damage incurred during shipping to a service center. SHURflo's obligation under this warranty policy is limited to the repair or replacement of the pump. Pumps found not defective (under the terms of this limited warranty) are subject to charges to be paid by the returnee for the testing and packaging of "tested good" units. Warranty returns will be shipped on a freight allowed basis. SHURflo reserves the right to choose the method of transportation. SHURflo is not responsible nor will it reimburse for labor necessary to remove and reinstall a pump, if found defective. This warranty is only a representation of the complete Marine Products Limited Warranty outlined by Service Bulletin #1050.



- ES** Favor de referirse a www.shurflo.com para instrucciones de la instalación del producto y su operación, disponible en varios idiomas.
- DE** Mehrsprachige Hinweise zu Installation und Betrieb des Produktes finden Sie unter www.shurflo.com
- IT** Fare riferimento al sito www.shurflo.com per manuali multilingue di installazione ed utilizzo prodotti.
- FR** Veuillez vous référer au site www.shurflo.com pour l'installation produit multilingue ainsi que pour le mode d'emploi.
- UK** Please refer to www.shurflo.com for multi-lingual product installation and operating instructions'

SHURflo reserves the right to update specifications, prices, or make substitutions.



SHURflo, LLC Headquarters
 5900 Katella Avenue
 Cypress, California 90630
 Phone (562) 795-5200 • Toll Free (800) 854-3218
 Fax (562) 795-7564

SHURflo, LLC East
 52748 Park Six Court
 Elkhart, Indiana 46514-5427
 Phone (562) 795-5200 • Toll Free (800) 854-3218
 Fax (574) 264-2169

SHURflo Europe, Middle East, Africa
Pentair Water Belgium bvba,
 Industriepark Wolfstee, Toekomstlaan 30
 B-2200 Herentals, Belgium
 Phone +32-14-283500 • Fax +32-14-283505