

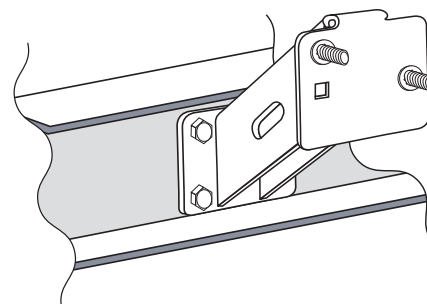

best in the  
**LongRun**



## Spare Tire Carrier Instructions

For Aluminum Trailers Part #86064

### TOOLS REQUIRED:

Wrench or 1/2" Socket Wrench, Drill & 9/16" Bit

1. Using the spare tire carrier and spare tire as a guide, determine a suitable mounting location on trailer I-beam. Using a felt tip marker, mark drill hole patterns for the four mounting holes.
2. Drill four 9/16" holes through the I-beam.
3. Place the carrier against the I-beam. Align mounting holes with hex head bolts.
4. Place the mounting plate against the outside of the frame with the 1/2" bolts.
5. Hand tighten nyloc nuts.
6. Using the spare tire to determine the correct holes to use, place the carriage bolts provided for mounting the spare tire in the holes of the rectangular plate. Bolt heads should be on the back side of the tire carrier.
7. Check position of the tire mount for proper clearance with the spare tire before tightening bolts.
8. Tighten remaining nuts and bolts on the I-beam.
9. Mount spare tire and tighten with lug nuts.

Drill hole measurements:

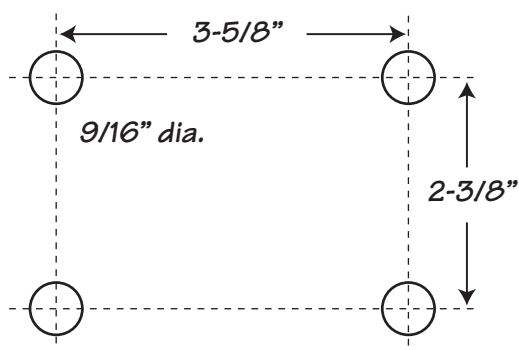

1/2" Nyloc Hex Nuts (4)

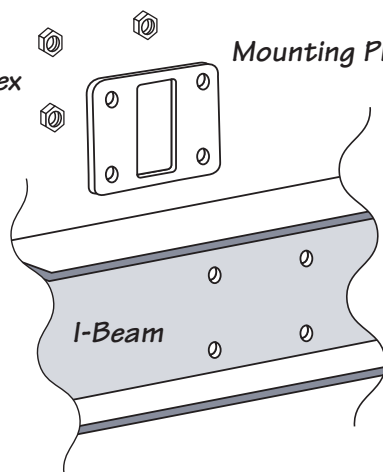

Mounting Plate

I-Beam

1/2" x 1-3/4" Carriage Bolts (2)

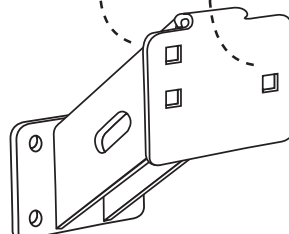

Star Washers

1/2" x 1-1/2" Bolts (4)

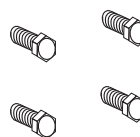

Instruction Sheet #08073

**TIE DOWN ENGINEERING • 255 Villanova Drive SW • Atlanta, GA 30336**  
**www.tiedown.com (404) 344-0000 Fax (404) 349-0401**



022210-A878