

INSTALLATION INSTRUCTION AND SERVICE MANUAL

Actuator/Trailer Dealer - Please provide these instructions to the consumer.
Consumer - Read and follow these instructions. Keep them with the trailer for future reference.

TITAN MODEL 10

SURG-O-MATIC ACTUATOR FOR TRAILER BRAKES

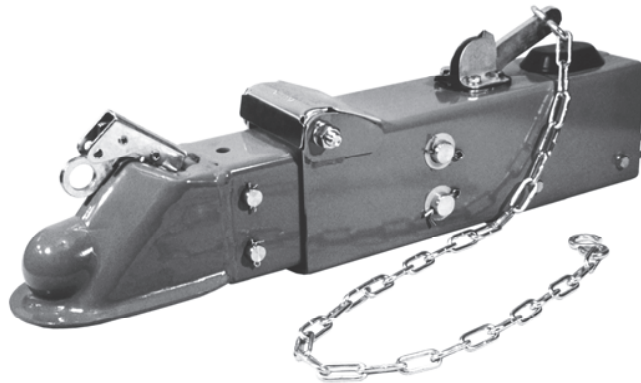

INTRODUCTION TO SURGE BRAKING

Surge braking is accomplished by replacing a trailer's standard tongue coupler with an actuator and adding hydraulic brake assemblies. The "surge" or "push" of the trailer toward the tow vehicle during deceleration automatically synchronizes these trailer brakes with the tow vehicle brakes. As the trailer pushes against the vehicle, the actuator telescopes together and applies force to its master cylinder, supplying hydraulic pressure to the trailer's brakes.

Surge actuators of this type provide a service life of approximately five years with proper installation, usage, and maintenance. However, a well cared-for actuator can often exceed this estimate. To get the most benefit from your TITAN surge actuator, follow the instructions given in this manual and use common sense in caring for the TITAN MODEL 10 actuator and your entire trailer brake system.

RATED CAPACITY AND USAGE

⚠ WARNING ⚠
DO NOT exceed these ratings

10,000 POUNDS MAXIMUM GROSS LOAD (weight of the trailer fully loaded with all cargo and equipment). To find your trailer's Gross Load, use a commercial vehicle scale at a truck weigh station, grain elevator, etc.

800 POUNDS MAXIMUM TONGUE LOAD (weight applied downward by the fully loaded trailer's coupler onto the tow vehicle's hitch). Your trailer's tongue load may be checked using a commercial scale. Make sure the tongue is in horizontal position and the jack is the only component on the scale. Upward tongue loads are not permissible.

The Model 10 actuator is intended for use on heavier recreational and light industrial trailers. The actual in-service rating is limited to that of the ball and hitch being used or the trailer manufacturer's G.V.W.R. shown on the certification label, which ever is lower.

TITAN
A Titan Company
2345 East Market Street
Des Moines, IA 50317
800-USA-BEAR or 800-872-2327
FAX 515-265-9301

INSTALLATION

⚠ WARNING ⚠

DO NOT submerge the actuator. Internal corrosion may result and cause brake failure. Salt water, granular fertilizers, and other corrosive materials are destructive to metal. To minimize the damaging effect of corrosion on a braking system used under corrosive conditions, we recommend that the actuator be externally flushed after use with a high pressure water hose. Be sure to lubricate all moving parts after the unit has dried. Whenever the unit will be out of service for an extended period of time, or after hard use, remove the brake drums and clean inside the brakes. Pack wheel bearings with grease before the drum is installed. Failure to properly and adequately grease and maintain the actuator could weaken it and/or cause it to fail and result in serious injury and/or property damage.

- The MODEL 10 Actuator is completely assembled and ready to bolt or weld into place onto straight three inch wide trailer tongues. Welding will make repair or replacement difficult but may be preferred. If the actuator must be painted for aesthetic reasons, then TITAN recommends painting ONLY the outer case and disassembling the unit prior to painting. Application of heavy coats of paint may interfere with component operation. If the actuator is welded on, then be sure to weld in a well ventilated area. Confirm the coupler and breakaway mechanisms work properly before operation. Store actuators indoors and in their original shipping carton until the time of installation.
- For bolt on applications, bolt the actuator to the tongue using two 1/2 inch by 4 inch grade 5 or better bolts, nuts, and lock washers if using outer case #16568 or #24777 <46>. Figure 1 shows the standard mounting patterns used on three inch wide trailer tongues. If outer case #16855 or #24782 <47> is used, then the use of two 5/8 inch by 4 inch grade 5 or better bolts, nuts and lock washers is recommended. Light weight tongues require spacer tubes inside for reinforcement when bolting. Using a torque wrench, tighten mounting bolts to eighty (80) foot-pounds torque.

FIG. 1 - TRAILER AND TRAILER TONGUE BOLT PATTERN (side view shown)

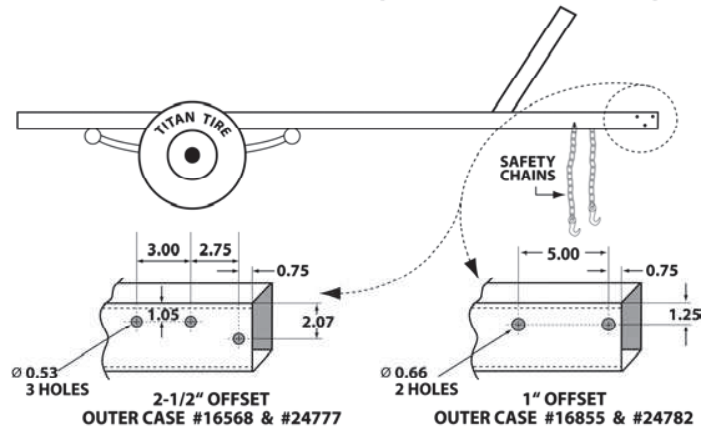

- Install the hydraulic brakes and brake lines on the trailer as described in the installation manual supplied with the brakes. TITAN recommends 3/16 inch brazed double wall tubing per S.A.E. J527 for use with all our actuator and brake products. Use forty-five degree (45°) double-flare tube ends per S.A.E. J533. **DO NOT** remove or modify the orifice connector <23> at the rear of your actuator's master cylinder. It connects directly to the brake tubing and ensures proper fluid flow characteristics. **FLEXIBLE BRAKE LINE HOSE MUST BE USED** to connect the orifice connector at the master cylinder to the hydraulic brake line on the trailer. This is necessary because the master cylinder is spring mounted to provide overload protection and thus moves relative to the outer case.
- After installation of the actuator, brakes, and brake lines as described above, proceed immediately to the "BRAKE FLUID FILLING AND BLEEDING" instructions (step #5).

⚠ WARNING ⚠

Failure to complete the "BRAKE FLUID FILLING AND BLEEDING" procedures promptly after installation may result in internal master cylinder corrosion and cause brake failure.

* NOTE: <#> is the reference number shown in the assembly diagram of the actuator located at the end of this manual
Page 2 of 13

INSTALLATION (cont.)

⚠ WARNING ⚠

Use only fresh brake fluid from a sealed container. DO NOT reuse fluid. After filling and bleeding, remember to refill the actuator. Failure to maintain an adequate fluid level may cause brake failure.

5. Fill the system with DOT 3-4 heavy-duty brake fluid. The braking system may be bled manually or with a vacuum or pressure brake bleeding system. Both types of brake bleeding equipment should be available at your local automotive jobber. Follow manufacturer's instructions.

Brake Fluid Filling and Bleeding

- 5a. After completing the "Installation" instructions, remove the master cylinder cap and fill the reservoir to three-quarters full with DOT-3 brake fluid. DO NOT allow brake fluid to contact painted surfaces since it will damage the finish. Wipe up any spills immediately and wash the area with water.
- 5b. If you choose to manually bleed the system, an assistant makes the job easier. Manually pull the actuator out to fully extended position. Loosen the four bolts on the breakaway lever (see Figures 3 & 4). Remove the back two bolts, rotate the two breakaway locks to the side and tighten the front two bolts. Pull the lever forward until nearly vertical and return normal operating position. Repeat this stroking action until the air stops bubbling inside the master cylinder. This pumps brake fluid into the trailer braking system.
- 5c. When the air bubbling stops inside the master cylinder, install a bleeder hose on the bleeder screw of the first wheel cylinder or disc brake caliper to be bled. Be sure to use the bleeder screw on top of the caliper. Start with the rear axle on tandem axle trailers. Submerge the other end of the hose in a glass container of brake fluid so that air bubbles can be observed. Open the bleeder screw one turn. Pull the breakaway lever completely forward or vertical and close the bleeder screw to prevent air from being pulled back into the system. Air trapped in the brake lines will greatly reduce your braking efficiency. Push the breakaway lever down to nearly flat position. Repeat this process until no more air bubbles are released with each stroke. Be sure to close the bleeder screw securely.
- 5e. Repeat the bleeding operation at each wheel cylinder or caliper. During the bleeding process, replenish the brake fluid so the level does not fall below half full level in the master cylinder reservoir. When bleeding is complete, fill the reservoir to within 3/8" of the top. Install the filler cap securely. To reset the breakaway lever, loosen the front two bolts. Position the breakaway lever and rotate the two breakaway locks (item 32 and 33) to their original operating or ready position. See figure 4. Install the two rear bolts and lock washers and tighten all four bolts to 90-120 inch pounds of torque.

TESTING TITAN SURGE BRAKE SYSTEMS

⚠ WARNING ⚠

It should be noted that the field-test procedure indicates only if the trailer brake system is functional, but **DOES NOT** provide information on how efficiently it will operate. Regular inspection, maintenance, and adjustment of all brake system components (including the surge actuator, tubing, hoses, brake clusters, drums or disc brake calipers and rotors and associated hardware/support structure) are still required to ensure maximum brake performance and smooth, even brake operation.

Hydraulic surge actuator systems provide automatic and smooth trailer braking without special application by the tow vehicle driver. While this is extremely convenient it can sometimes be difficult to determine if the surge setup is functioning properly. The following steps provide a quick field-test to confirm that the trailer brake system is operational.

1. Move the trailer to flat, level ground, pulling FORWARD several feet before parking. This forward motion will ensure trailers equipped with free-backing brakes are in their normal operating mode. Disconnect the trailer from the tow vehicle and jack the trailer's tongue until it is horizontal.
2. Hook the trailer's safety chains (NOT the actuator's break-away cable/chain) together to form a loop, which is centered below the actuator's coupler as shown in Figure 2.
3. Place a sturdy board, such as a 2 inch by 4 inch piece of lumber, into the chain loop below the coupler. The board should be 4 feet or longer so it will extend several feet above the actuator. Keep the end of the board a few inches off the ground, and position it to press against the front end of the actuator's coupler.
4. Stand in front of the trailer and face the rear. Apply force to the top end of the board to use it as a lever. Press back towards the rear of the trailer. The board will begin moving the coupler case (inner slide) into the actuator's outer housing.
5. Keep pressing the top of the board to stroke the actuator and its internal master cylinder. If the trailer brake system is operational, the brakes will apply and keep the trailer from rolling away from you. Disc brakes and properly adjusted uni-servo or duo-servo type brakes will prevent you from moving the trailer back more than a few inches. Free-backing type brakes will initially provide rolling resistance, but continued force on the board will switch them into free-backing mode, and you'll be able to move the trailer backwards.
6. If you have uni-servo, duo-servo, or disc brakes, if stroking the actuator (as described previously) causes the trailer to roll away from you freely or with only minimal resistance, the brakes are **NOT** applying properly. If you have free-backing brakes, and stroking the actuator (as described previously) causes the trailer to roll away without initial resistance, the brakes are **NOT** applying properly. The brake system **MUST** be evaluated to determine the cause of the problem, and corrective action **MUST** be taken before the trailer is used.

FIG. 2 - FIELD TEST SETUP

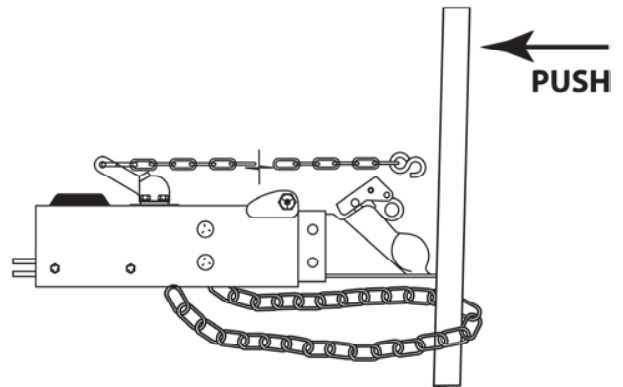

Use this procedure each time you tow your trailer to check your surge brake system operation.

HITCHING TRAILER

⚠ WARNING ⚠

To ensure proper engagement of the actuator's coupler to the tow ball, DO NOT use a multi-piece ball, an incorrectly sized ball, or a worn/damaged ball.

1. Confirm the towing hitch and ball have a rating equal to or greater than the trailer G.V.W.R. and are properly and securely attached to the tow vehicle. The hitch **MUST** be installed so the trailer tongue is level (horizontal) when coupled to the tow vehicle.
2. To hitch the 2-5/16 inch coupler to the tow vehicle, perform the following procedure. Open the coupler by lifting the handle assembly's lock trigger so it unhooks from the locked position, and then by swinging the top of the handle toward the rear of the actuator. Lower the coupler onto the ball confirming that the ball is fully seated in the coupler socket. Swing the handle back forward until the lock trigger hooks into the locked position to secure the ball. Check that the ball has been trapped in the coupler socket. A properly adjusted coupler will have between 1/64 inch and 1/32 inch of free play between the ball and ball socket. Do not tow the trailer if the coupler is damaged.
3. Check that the actuator's coupler, lunette eye, or clevis is securely attached to the tow vehicle by extending the trailer's tongue jack to the ground. Use it to lift the trailer tongue and tow vehicle hitch two to four inches. The actuator and hitch should remain engaged. **DO NOT** tow the trailer unless the actuator is securely connected to the tow vehicle. Retract the trailer tongue jack before towing.

⚠ WARNING ⚠

An incorrect lever or chain position may cause the trailer brakes to drag and overheat, or may keep the brakes from being applied in a break-away situation. After any usage of the break-away mechanism, either real or accidental, check all system components (lever, chain, S-hooks, break-away locks, and break-away bolts etc.) for damage. Replace any damaged items with genuine TITAN service parts.

4. The 2-5/16 ball coupler mechanism may be further secured by performing the following steps. With the handle in the locked (down) position, insert either a standard padlock or spring pin through the hole in the side of the handle assembly. This will lock the handle in the down position and further prevent the handle ball latch assembly from swinging upward and opening. Do not use padlocks or pins which interfere with the telescoping action of the actuator and thereby compromise braking performance.

⚠ WARNING ⚠

The trailer safety chains' length **MUST be set short enough so the actuator's break-away cable is **NOT** pulled if the coupler separates from the tow vehicle's hitch but remains connected by the safety chains. The break-away system should only be activated after **BOTH** the trailer's coupler **AND** safety chains have failed and allowed the trailer to completely separate from the tow vehicle. Provide just enough slack in the trailer safety chains to allow tight turns. The chains should not drag on the ground. Safety chains must be used.**

5. To uncouple the trailer, first block the wheels to keep the trailer from rolling. Lift the actuator handle fully to disengage the hitch ball. Use the tongue jack to lift the trailer tongue off the hitch ball.
6. As shown in Figure 3, your tow vehicle's hitch provides a safety chain hole or ring on each side. Consult your trailer manufacturer for proper safety chain recommendations. Attach your trailer's safety chains securely to these connection points, being sure to cross the chains **UNDER** the trailer tongue. Safety chains **MUST** be used. This will prevent the trailer tongue from dropping to the road if the coupler separates from the tow vehicle's hitch. If your tow vehicle's hitch does not provide safety chain connection points, have appropriate ones added by a reputable hitch installer.

* NOTE: <#> is the reference number shown in the assembly diagram of the actuator located at the end of this manual
Page 5 of 13

HITCHING TRAILER (cont.)

7. Attach the actuator's break-away chain S-hook securely to one of the tow vehicle hitch's safety chain connection points (see Fig. 3). Confirm that the trailer's safety chains are adjusted relative to the actuator's breakaway chain as noted above. DO NOT loop the breakaway chain around a bracket and hook it back onto itself.

FIG. 3 - SAFETY CHAIN AND BREAK-AWAY CHAIN ATTACHMENT
(top view shown)

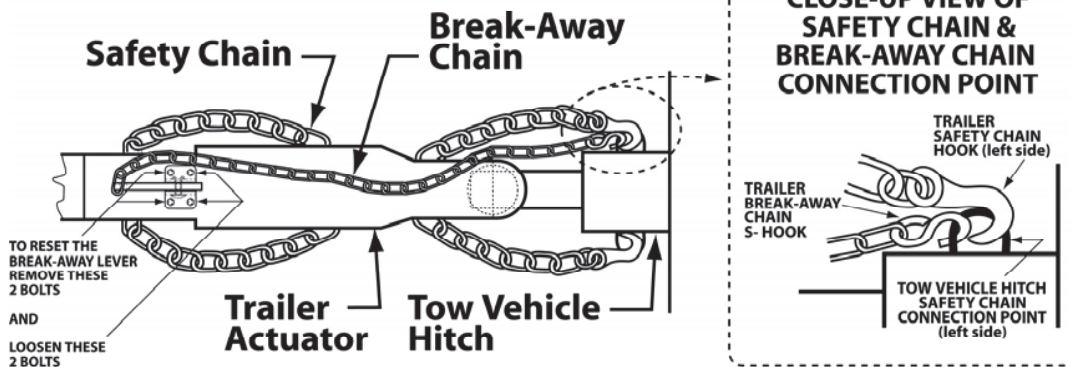

8. Before towing, check that the break-away lever and chain are properly positioned as shown in Figure 4. If the break-away lever and chain are not located correctly as described above, due to either the chain being pulled during use or by accident, it MUST be reset prior to the trailer being moved.

FIG. 4 - BREAK-AWAY LEVER

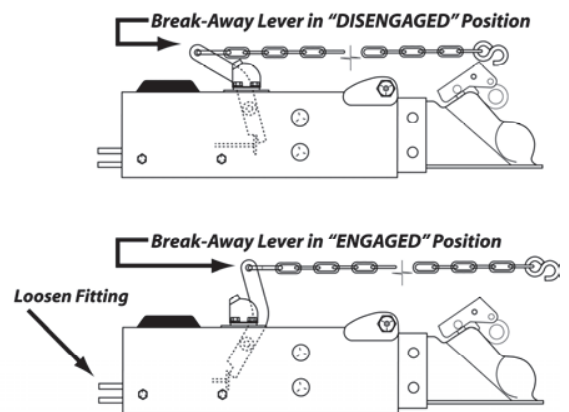

9. **Resetting the Breakaway Lever** (see Fig. 3 & 4) Carefully loosen the brake line fitting going into the actuator. After the pressure is gradually released, retighten the fitting. Then remove the two rearward bolts <15>, one located on each side of the breakaway lever <10>. These two bolts hold down the break-away locks <12 & 13>. Loosen, but do not remove the two remaining bolts <15>. This will allow the two locks to be swung aside and the lever can be pushed back into its resting position. Rotate the break-away locks to their original positions and use a torque wrench to tighten the four bolts to 90-120 inch-pounds of torque.

10. When this actuator is used with disc brakes or non free-backing brakes, our solenoid backup valve part number 4748800 will allow the trailer to be backed without activating the brakes. Do not block actuator movement in and out to back up the trailer. Failure to remove the blocking device will prevent all trailer braking.

⚠ **WARNING** ⚠

The hydraulic pressure held in the system may cause the lever to snap back quickly. Keep hands and fingers clear as you reset the break-away mechanism.

⚠ **WARNING** ⚠

The break-away system is not designed to operate if the trailer does not separate completely from the tow vehicle, or if the trailer tongue "submarines" and goes beneath the tow vehicle. DO NOT use the break-away system as a parking brake.

* NOTE: <#> is the reference number shown in the assembly diagram of the actuator located at the end of this manual
Page 6 of 13

MAINTENANCE

1. Before each towing, perform the following steps:

- Check that the brake fluid reservoir is three-quarters full of DOT 3-4 brake fluid. Check for leaks and repair as required.

⚠ WARNING ⚠

Use only fresh brake fluid from a sealed container. DO NOT reuse fluid. After filling and bleeding, remember to refill the actuator. Failure to maintain an adequate fluid level may cause brake failure.

- Examine the actuator for wear, bent parts, corroded/seized parts, or other damage. Have the affected components replaced with genuine TITAN service parts. Check to determine that the actuator mounting bolts (where applicable) are tightened to eighty (80) foot-pounds torque using a torque wrench.
 - Test the actuator and brake function as described in the "TESTING TITAN SURGE BRAKE SYSTEMS" section of this manual. Actuator travel over one inch indicates that the brakes need adjustment (or that the actuator has been structurally damaged). Actuator travel is the distance the coupler case assembly <3> moves relative to the outer case <2> during braking. Adjust the brakes following the instructions given in the brake installation manual. In general, back off adjusters ten clicks from locked drum rotation. Adjust free-backing brakes by rotating in the forward direction only. Failure to adjust brakes will result in loss of braking.
2. A film of grease on the hitch ball will extend coupler and ball life while eliminating squeaking. Wipe clean and renew film each time trailer is used.
3. There are no adjustments on the actuator.
4. Actuator travel (over one inch) shown by front roller path indicates a need to adjust the brakes. Adjust per instructions found in brake installation manual. In general, back-off adjusters 10 clicks from locked rotation. Adjust Free-Backing brakes by rotating in forward direction only. Failure to adjust may result in loss of braking.
5. Before storage or after extended use, TITAN recommends applying motor oil to the coupler components, lockout mechanism, and the three internal rollers to keep them moving freely and to prevent corrosion.

MODEL 10 ASSEMBLY

1. Over time, you may need to disassemble your TITAN Model 10 for service or to replace components. Use the following steps to put the actuator back together, checking this manual's assy. diagram and parts list for reference.
2. Position the small diameter end of the damper < 29 > to line up with the lower holes in the front of the inner slide < 18 >. Install damper pin < 33 > and secure it with a cotter pin < 6 >. Repeat the process with the second damper in the upper holes of the inner. It may be easier to reassemble the inner by making two "dummy" pins out of 3/4" diameter wooden dowels. Cut them the same length as the width of the inner. Insert one of the wooden dowels into the edge of the top slot of the inner < 18 >. Then slide the dowel through a rear roller < 30 > with the chamfered edge out, then through the end of the damper < 29 >, and finally through another rear roller with the chamfered edge out. Then install the second dowel into the bottom slot and through the end of the bottom damper. Carefully insert the inner slide < 18 > into the outer case, maintaining the position of the components. Take a master pin < 31 > and position it end to end with the top dowel. Use the master pin to slide the dowel through the inner slide and components. Then install a nylon washer < 48 > on the master pin and secure it with cotter pin. Repeat the process with the bottom master pin.

⚠ WARNING ⚠

An incorrect lever or chain position may cause the trailer brakes to drag and overheat, or may keep the brakes from being applied in a break-away situation. After any usage of the break-away mechanism, either real or accidental, check all system components (lever, chain, S-hooks, break-away locks, and break-away bolts etc.) for damage. Replace any damaged items with genuine TITAN service parts.

3. Take the front roller < 4 > and place in position in the front roller cover < 7 >. Line up the holes in the roller cover and the outer case and thread the roller bolt < 5 > through the outer case, roller cover, and the roller. Secure the bolt with the lock washer < 40 > and the nut < 41 >. Tighten nut to 75 ft - lbs.
4. Place the breakaway lever assembly < 10 > in the rectangular opening in the top of the outer case. Install the weather seal < 11 > with the slot forward on top of the brackets. Position the right < 13 > and left < 12 > breakaway locks and start the four 5/16" bolts < 15 > with lock washers < 14 >. Move the breakaway lever to vertical position and use locking pliers to hold the breakaway locks close to the lever to assure the tabs will hold the lever in position. Then tighten the bolts to 90 – 120 inch pounds of torque. Spread the top of the breakaway locks to allow the breakaway lever to move down to normal operating position (about 45 degrees).
5. Remove the filler cap from the master cylinder and slide the assembly into the back of the outer case. Line up the front holes first and start two 5/16" bolts < 15 > and lock washers < 14 >. Repeat the process for remaining bolts and tighten all bolts. Then thread the filler cap in the master cylinder and install the cylinder cover < 16 >.
6. The actuator should now be fully assembled and ready for installation as described in this manual.

ADJUSTABLE ASSEMBLIES

Part #	Description
2330900	2 5/16" Ball Coupler (Includes Channel, Bolts, and Nuts)
0909500	3/4" Clevis (Includes Channel, Bolts, and Nuts)
1812800	3" Lunette Eye (Includes Channel, Bolts, and Nuts)

ADJUSTABLE ASSEMBLY PARTS ONLY

Ref #	Part #	Description
34	0897800	Channel
35	0897900	3/4" Clevis, 2 bolt
36	0909300	Bolt, Hex 5/8" NC x 4 1/2"
37	1040500	Lock Nut 5/8" NC
44	1882000	2 5/16" adjustable ball coupler
45	1613700	3" Lunette Eye

REPAIR KITS

Part #	Description
1018700	1 1/4" Master Cylinder Repair Kit
1848700	2 5/16" Ball Coupler Repair Kit

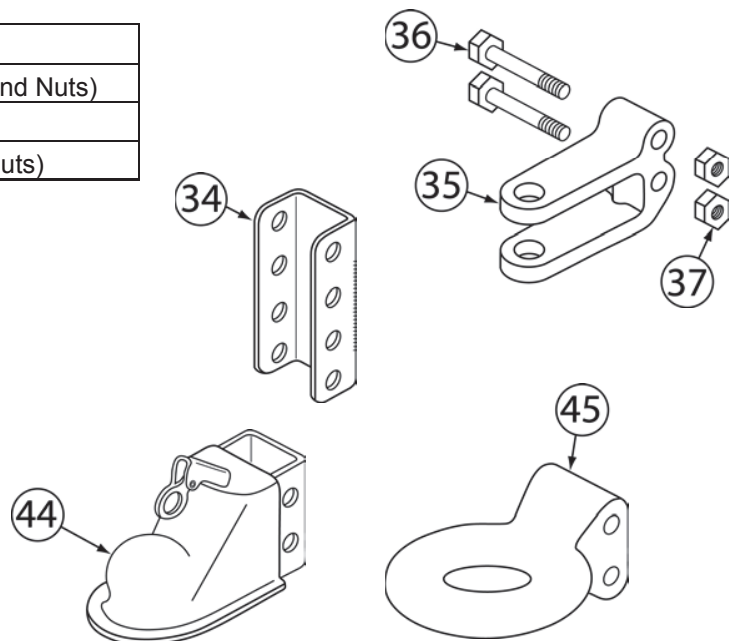

* NOTE: <#> is the reference number shown in the assembly diagram of the actuator located at the end of this manual
Page 8 of 13

MODEL 10 ACTUATOR PARTS DIAGRAM

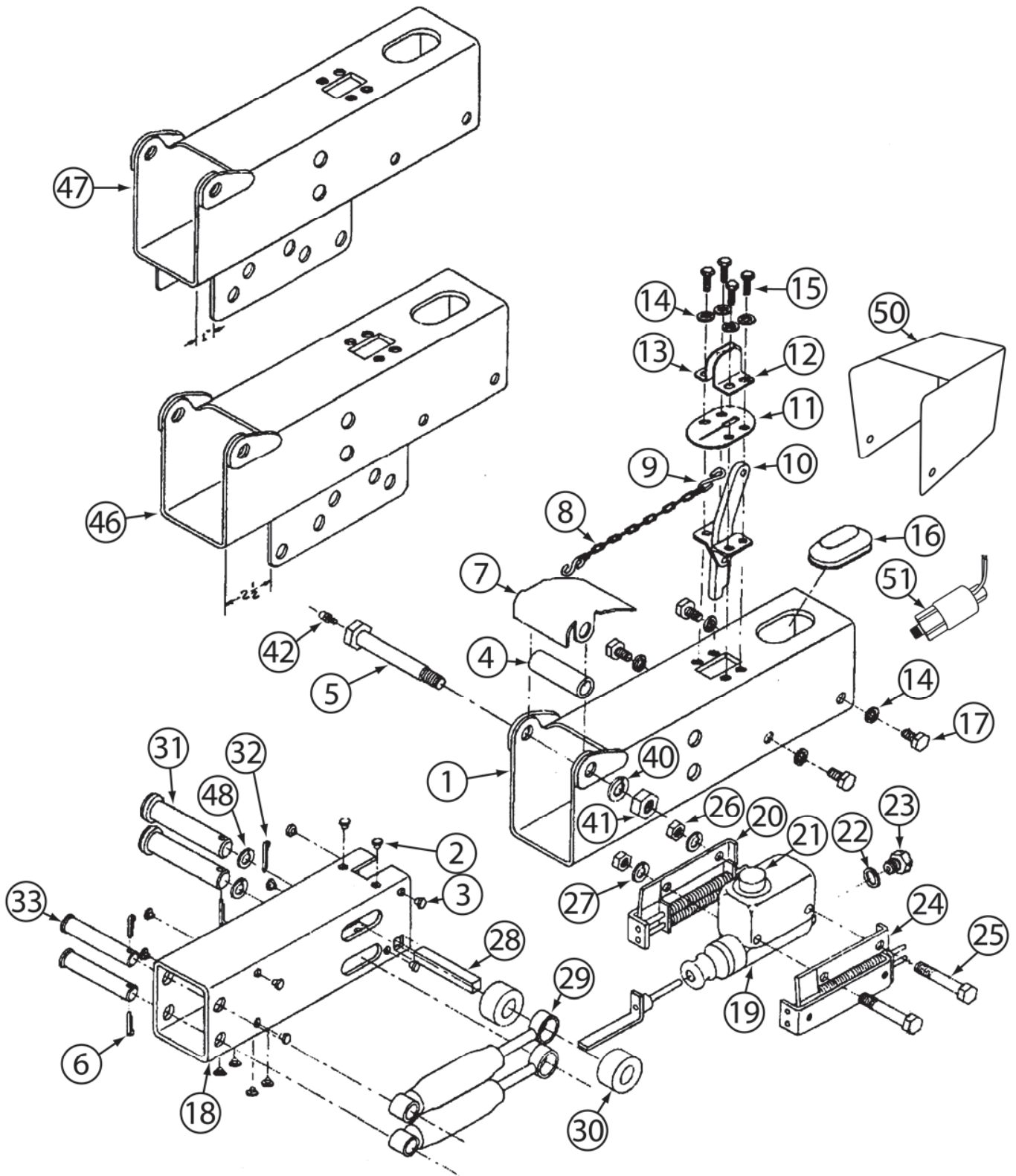

MODEL 10 ACTUATOR PARTS LIST

(ref. Parts Diagram on page 9)

KEY #	PART NUMBER	DESCRIPTION	QTY
1	1601600	Outer case, painted	1
2	1020900	Bearing (top & bottom) .125" thick	6
3	1242700	Bearing (side) .075" thick	8
4	1601900	Front Roller	1
5	0828800	Front Roller Bolt	1
6	0799700	Cotter Pin 1/8" X 1"	2
7	1601800	Front Roller Cover	1
8	0776800	Breakaway Chain	4
9	1055500	S-Hook	2
10	1054100	Breakaway Lever Assembly	1
11	1055200	Weather Seal	1
12	1052600	Breakaway Lock - Left Hand	1
13	1052700	Breakaway Lock - Right Hand	1
14	0793800	Lockwasher 5/16" standard	8
15	0794900	Bolt - Hex 5/16" -18NC x 5/8" long	4
16	1507000	Cylinder Cover	1
17	0794800	Bolt - Hex 5/16" -18NC x 1/2" long	4
18	1593300	Inner Slide	1
19	2374400	Master Cylinder, 1 1/4" bore, drum brake	1
*	4831600	Master Cylinder, drum, with 1209800 orifice	
	4747100	Master Cylinder, 1 1/4" bore, disc brake	
20	0838800	Cylinder Bracket, Right Hand	1
21	1250300	Filler Cap (included in 2374400)	1
22	0774500	Gasket, for use with 1209900 orifice	1
23	1209800	Orifice connector, drum brake, 1/8" NPT	1
	1209900	Orifice, drum, early type, 1/2" NF thread	1
24	0838900	Cylinder Bracket, Left Hand	1
25	0827100	Bolt - Hex 3/8" - 16NC X 3" long	2
26	0797600	Hex Nut 3/8" - 16NC	2
27	1255200	Star Lockwasher 3/8"	2
28	0830100	Push Rod Block	1
29	1242600	Damper	2
30	0829100	Rear Roller	2
31	1593500	Master Pin	2
32	0815200	Cotter Pin 3/16" X 1 1/4"	2
33	1593400	Damper Pin	2
40	0793700	Lockwasher 1/2"	1
41	0798500	Hex Nut 1/2" - 13NC	1
42	0144901	Grease Zerk	1
46	2477700183	Outer case, 2.5" offset mtg channel, plated	1
	2477700317	Outer case, 2.5" offset mtg channel, painted	1
47	2478200	Outer case, 1" offset mtg channel, plated	1
	1685500	Outer case, 1" offset mtg channel, painted	1
48	1861900	Nylon Washer	2

* = not shown

MODEL 10 ACTUATOR PARTS LIST (cont.)

(ref. Parts Diagram on page 9)

KEY #	PART NUMBER	DESCRIPTION	QTY
49	2374600	Drum Brake Master Cylinder Assembly complete with brackets	1
	4749501042	Disc Brake Master Cylinder Assembly complete with brackets	1
50	4836100183	Back up valve cover, plated	1
	4836100	Back up valve cover, painted	
*	1018700	Master cylinder repair kit	
51	4748800	Solenoid back up valve, male 1/8" NPT and female	1
		3/8" x 24 NF with inverted seat	
*	4750200	Adapter 1/2" NF to 1/8" NPT, for back up valve	1

* = not shown

MODEL 10 ACTUATOR PRODUCT LIST

DRUM BRAKE	DISC BRAKE	DESCRIPTION	ATTACHMENT	INNER	OUTER
1608000		No coupler, painted	Weld-on	1593300	1601600
2404600	4838000	W/leveler channel, painted	Weld-on	1608700317	1601600
4809700	4809900	W/leveler channel, plated	Bolt-on 5/8"	4721700	2478200
	4810000	W/leveler channel, plated, w/lunette eye	Bolt-on 5/8"	4721700	2478200
	4810020	Same as above w/solenoid valve & cover	Bolt-on 5/8"	4721700	2478200
4721600		W/leveler channel, plated	Bolt-on 1/2"	4721700	2477700183
1607500	4749600	2 5/16 coupler, straight, painted	Weld-on	1608400317	1601600
	4749610	2 5/16 coupler, straight, ptd, with cover	Weld-on	1608400317	1601600
	4749620	2 5/16 straight, ptd, with valve & cover	Weld-on	1608400317	1601600
1664300		2 5/16 coupler, 2.5" offset, painted	Bolt-on 1/2"	1608400317	2477700317
2477600	4750800	2 5/16 coupler, 2.5" offset, plated	Bolt-on 1/2"	1608400183	2477700183
	4750820	Same as above w/solenoid valve & cover	Bolt-on 1/2"	1608400183	2477700183
1735200	4830300	2 5/16 drop coupler, painted	Weld-on	2478300317	1601600
1772700	4830100	2 5/16 drop, 1" offset mtg channel	Bolt-on 5/8"	2478300317	1685500
	4837900	2 5/16 drop, painted	Weld-on	2478300317	1601600
2478100	4750600	2 5/16 drop, plated	Bolt-on 5/8"	2478300183	2478200
	4750610	2 5/16 drop, plated, with cover	Bolt-on 5/8"	2478300183	2478200
	4750620	2 5/16 drop, plated, with valve and cover	Bolt-on 5/8"	2478300183	2478200
1890900		2 5/16 adj coupler, painted	Weld-on	1608700317	1601600
4836700		W/leveler channel, 1" offset mtg channel	Bolt-on 5/8"	1608700317	1685500
4238300		2 5/16 adj coupler, 1" offset channel	Bolt-on 5/8"	1608700317	1685500
1891100		3" adjustable lunette eye, painted	Weld-on	1608700317	1601600
1607900		Adjustable clevis hitch, painted	Weld-on	1608700317	1601600
1607700		3" lunette eye, painted	Weld-on	1608600	1601600
1664500		3" lunette eye, 2.5" offset mtg channel	Bolt-on 1/2"	1608600	2477700317
1664900		No coupler, 2.5" offset mtg channel	Bolt-on 1/2"	1593300	2477700317
4238500		3" adj lunette eye, 1" offset mtg channel	Bolt-on 5/8"	1608700317	1685500
4299600		2 5/16 drop, 2.5" offset mtg channel	Bolt-on 1/2"	2478300183	2477700183
2324800		W/leveler channel, 2.5" offset mtg channel	Bolt-on 1/2"	1608700317	2477700317

MODEL 10 ACTUATORS

(ref. Product List on page 11)

1608000
BODY ONLY WELD ON

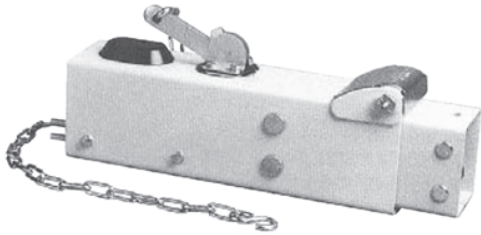

2477600
2-5/16" COUPLER 1/2" BOLT ON, PLATED

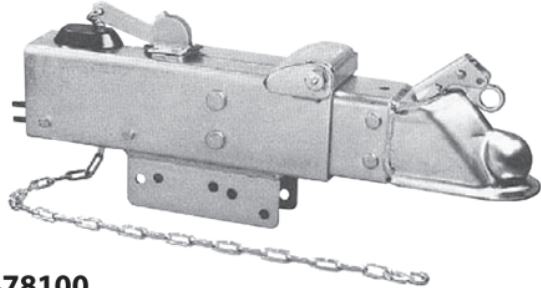

1607500
2-5/16" BALL COUPLER WELD ON

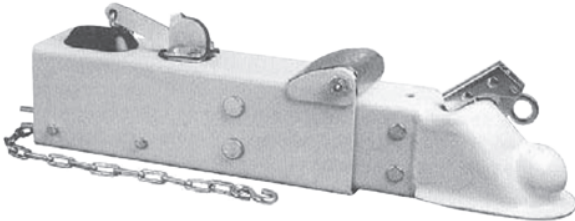

2478100
2-5/16" DROP COUPLER 5/8" BOLT ON, PLATED

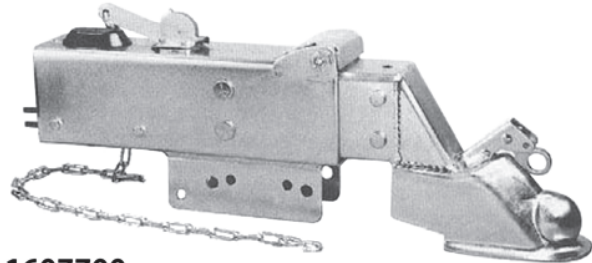

2404600
BODY ONLY ADJUSTABLE WELD ON

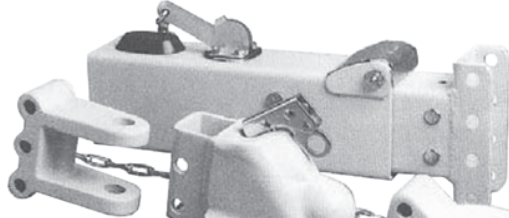

1607700
3" LUNETTE EYE WELD ON

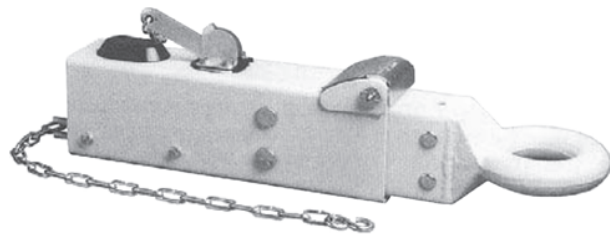

1807800
1" CLEVIS **1882000**
2-5/16" BALL COUPLER

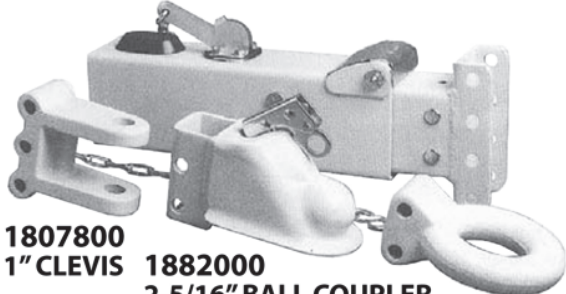

1613700
LUNETTE EYE



LIMITED WARRANTY

Limited Warranty Titan Tire Corporation (TITAN) warrants its products to be free from defects in material and workmanship for one year from date of delivery to the original purchaser when properly installed, used and maintained by the purchaser.

This warranty does not apply to damage or loss caused by any or all of the following circumstances or conditions:

- Freight damage.
- Parts, accessories, materials or components not obtained former approved in writing by TITAN.
- Misapplication, misuse and failure to follow the directions or observe cautions and warnings on installation, operation, application, inspection or maintenance specified in any TITAN quotations, acknowledgements, sales literature, specification sheet or installation instructions and service manual ("applicable literature")

If any TITAN products are found upon TITAN's examination to have been defective when supplied, TITAN will either: credit the purchaser's account for the purchase price of the TITAN product; or repair the product. TITAN has sole discretion in choosing which option to provide. For this LIMITED WARRANTY to apply, TITAN must receive notice of the alleged defect within 30 days of either the discovery of the alleged defect or the expiration of the warranty period, whichever is earlier. Any claim not made with in this period shall conclusively be deemed waived.

If requested by TITAN, purchaser shall return the alleged defective product to TITAN for examination at Titan's direction and expense. TITAN will not pay for expenses incurred in returning a product to TITAN without TITAN'S prior written authority. TITAN shall not be liable for any other expenses purchaser incurs to remedy any defect. Purchasers waive subrogation on all claims under any insurance.

Limitation of Liability It is expressly agreed that the liability of TITAN is limited and TITAN does not function as an insurer. THE REMEDIES SET FORTH IN THIS WARRANTY SHALL CONSTITUTE THE EXCLUSIVE REMEDIES AVAILABLE TO THE PURCHASER OR USER AND ARE IN LIEU OF ALL OTHER REMEDIES, EXPRESS OR IMPLIED. THE LIABILITY OF TITAN, WHETHER IN CONTRACT, IN TORT, UNDER ANY WARRANTY OR OTHERWISE, SHALL NOT EXCEED THE PURCHASE PRICE OF THE PARTICULAR PRODUCT MANUFACTURED, SOLD OR SUPPLIED BY TITAN.

To Obtain Technical Assistance To enable TITAN to respond to a request for assistance or evaluation of customer or user operation difficulty, please provide at a minimum the following information by calling 1-800-872-2327 or within Iowa 1-515-265-9200:

- Model number, serial number and all other data on the specific component which appears to be involved in the difficulty.
- The date and from whom you purchased your TITAN product.
- State your difficulty, being sure to mention at least the following: Application, Nature of load involved, and Weight of the load.

Field Service If field service at the request of the purchaser is rendered and the difficulty is found not to be with TITAN'S product, the purchaser shall pay the time and expense (at the prevailing rate at the time of service) of the seller's field representative(s). Charges for service, labor and other expenses that have been incurred by the purchaser, its customer or agent without prior written authorization of TITAN will not be accepted.

TITAN EXTENDS NO WARRANTY, EXPRESS OR IMPLIED, ON PRODUCTS NOT MANUFACTURED BY TITAN OR TO TITAN'S DESIGN SPECIFICATION, INCLUDING BUT NOT LIMITED TO SUCH ITEMS AS NON-TITAN TIRES, BRAKES, ACTUATORS, BEARINGS, HOSE AND TUBING, PURCHASER'S RECOURSE SHALL BE LIMITED TO ANY WARRANTY OF THE PERSPECTIVE MANUFACTURERS.

THIS WARRANTY EXCLUDES ALL IMPLIED WARRANTIES OF MERCHANTABILITY OR FITNESS FOR A PARTICULAR PURPOSE OR ANY PURPOSE.

THIS WARRANTY DOES NOT COVER NOR EXTEND TO INCIDENTAL OR CONSEQUENTIAL DAMAGE. Some states do not allow the exclusion or limitation of incidental or consequential damages, so the above limitation or exclusion may not apply to you.

No representative has authority to make any representation, promise or agreement except as stated in this Limited Warranty. TITAN reserves the right to make design and other changes upon its products without any obligation to install the same on any previously sold or delivered products.

THERE ARE NO WARRANTIES WHICH EXTEND BEYOND THOSE DESCRIBED ABOVE. EFFECTIVE JANUARY 1, 1998 THIS WARRANTY SUPERSEDES ALL PRIOR WARRRANTIES, WRITTEN OR IMPLIED.