



Pneumatic Control Schematics

- **Applications shown in the document are:** Lift axle circuits, suspension dump circuits and tailgate control circuits for single acting air cylinders. (Air to open spring to close) Single acting air cylinders require what is known as a 3 way valve function. Because Velvac valves are multi-purpose we can also control double acting air cylinders (air to open air to close) if required using the same valve but as a 4 way function.
- **Solenoid or “Electric Over Air” Valves:** Many of the circuits shown here use solenoid operated valves as well as air pilot operated valves and a few manual valve control circuits.
- **Remote Manual Operation (on the trailer):** The circuits shown here all are drawn with the ability to control the valve from inside the cab with an electrical “flip switch” or the operator can also control the axle, suspension or tailgate from outside the cab with a manual valve. The manual valve can be either a separate Push-Pull style valve or, can also be a 3 way function manual valve mounted right to the power valve we have both options.
- **The “12” Flow Condition:** All valves shown in this document are known as “12” flow condition valves. This means that when the valve is used as a **single pressure supply** valve and the solenoid is not energized and air will flow from port #1 to port #2 and air will exhaust from port #4 to port #5. When the solenoid is energized the valve shifts and supply air flows from port #1 to port #4 and exhausts from port #2 to port #3.



Pneumatic Control Schematics

- **Dual Pressure Applications - Lift Axle Control:** All 5 ported valves offered by Velvac Inc, and shown in this document are capable of being used as dual pressure valves for lift axle control applications.
- **Dual Pressure Function:** air is supplied to ports #3 and port #5 and port #1 becomes a common exhaust port. When the solenoid is not energized air will flow from port #5 to port #4 and air will exhaust from port #2 to port #1. When the solenoid is energized the valve shifts and supply air flows from port #3 to port #2 and exhausts from port #4 to port #1.
- **Three Basic Plumbing Layouts For Dual Pressure Lift Axle Control:**
- **1. Dual Pressure supply with a Leveling Valve (or Height Control Valve - HCV)** supplying the reduced pressure for down bags. The valve is plumbed as a dual pressure supply valve. Reduced air pressure is supplied to port #3 from the Leveling Valve (LV) or HCV and port #5 is supplied with full line pressure port #1 becomes a common exhaust port. When the **solenoid is not energized** high pressure air will flow from port #5 to port #4 and fill the lift bags and air will exhaust from port #2 to port #1. When the solenoid is energized the valve shifts and supply reduced air pressure from the Leveling Valve flows from port #3 to the down bags at port #2 and exhausts from port #4 to port #1. (See Slide #4 & #5)
- **2. Dual Pressure with Regulator supplying the reduced pressure** for down bags. The valve is plumbed as a dual pressure supply valve. Reduced air pressure is supplied to port #3 from a pressure regulator and port #5 is supplied with full line pressure port #1 becomes a common exhaust port. When the **solenoid is not energized** high pressure air will flow from port #5 to port #4 and fill the lift bags and air will exhaust from port #2 to port #1. When the solenoid is energized the valve shifts and supply reduced air pressure from the regulator flows from port #3 to the down bags at port #2 and exhausts from port #4 to port #1. (See Slide #6 & #7)



Pneumatic Control Schematics

- **3. Single full line pressure supplied to the valve at port #1 down bag pressure reduced “after” the valve.** Full line pressure is supplied to the “up or lift bags” straight through the valve. Reduced pressure is supplied to the “down bags” by placing a pressure regulator (pressure reducing valve) in the air lines connected to the “down bags” after the lift axle control valve (also known as power valve). The regulator must have what is known as “full flow in reverse capability” or it can cause sluggish or inconsistent operation. *(See Slide #10 & #11)*
- *There are many additional ways to plumb control circuits for lift axle control but the three methods listed above are the most commonly used.*
- **You Must Always Externally Pilot All Dual Pressure Supplied Valves:** All solenoid valves that are used in the dual pressure supply mode must be supplied with at least 75 PSI to the 1/8” external pilot port located on the bottom of the solenoid operator. This is usually done by using a Tee fitting tied into a high pressure supply line from an air tank.
- You have the option of externally piloting any solenoid valve from Velvac but it is **only required** if the internal pilot supply is not a high enough pressure for proper operation (65-75 PSIG) or an internal pilot supply cannot be communicated to the solenoid operator because the #1 port is not being used as the supply port; this is the case when valves are used as dual pressure supply valves.

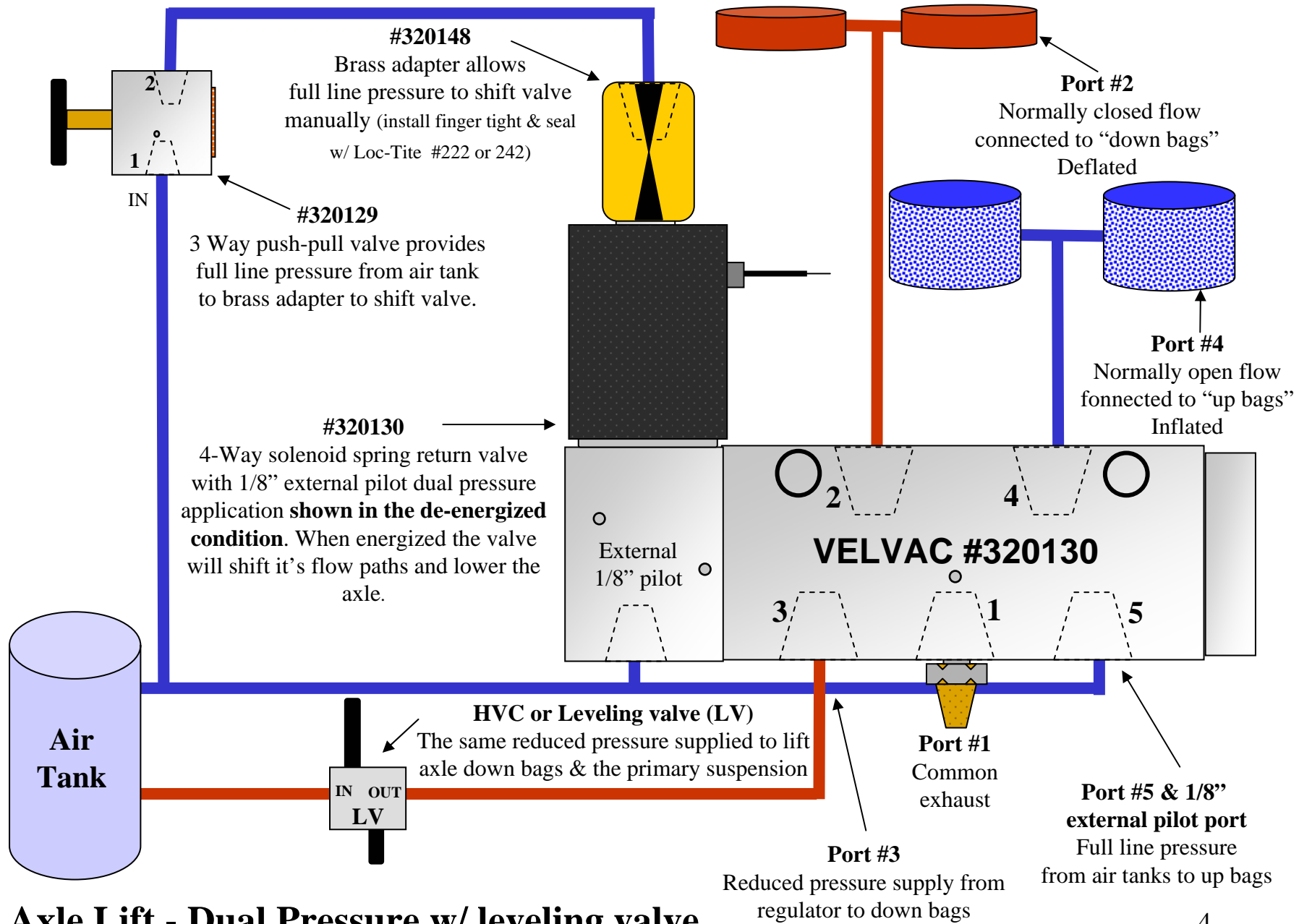

Axle Lift - Dual Pressure w/ leveling valve

#320144

4-Way solenoid spring return air operated manual override dual pressure application shown in the de-energized condition.

When energized the valve will shift it's flow paths and lower the axle.

Manual override knob detented air pressure shifts the valve (electric on = axle down)

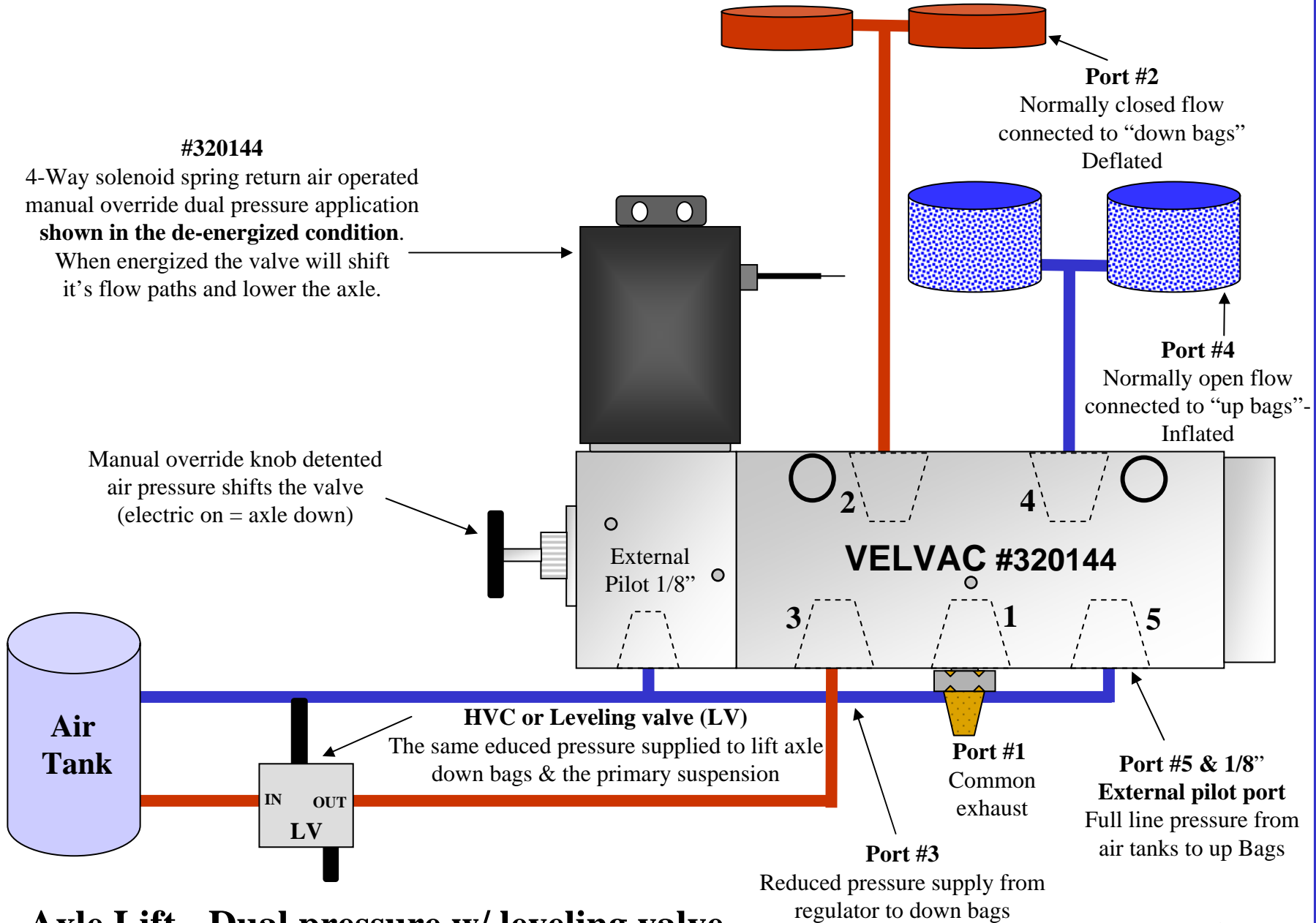

Axle Lift - Dual pressure w/ leveling valve

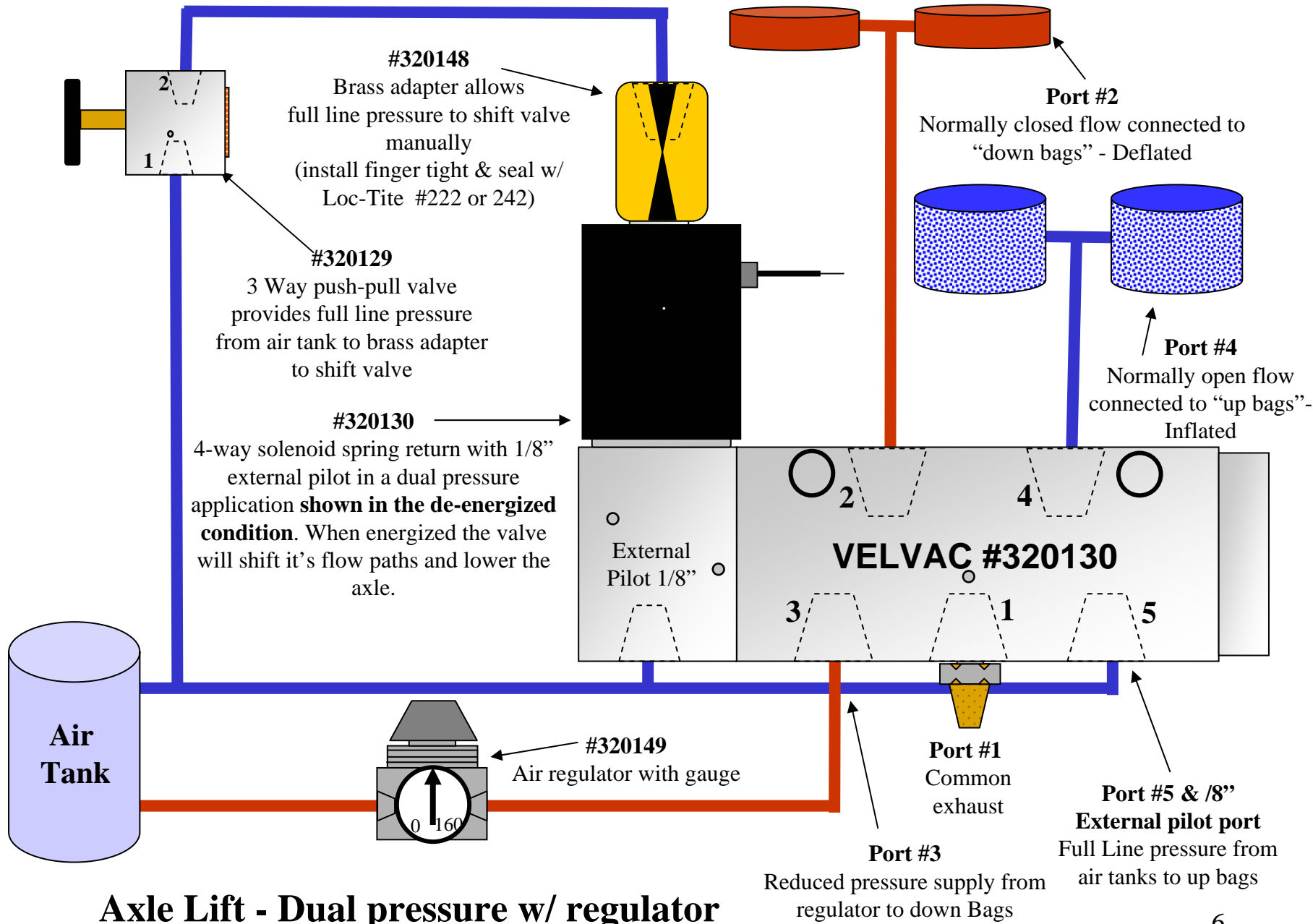

Axle Lift - Dual pressure w/ regulator

#320144

4-Way solenoid spring return air operated manual override dual pressure application shown in the de-energized condition.

When energized the valve will shift it's flow paths and lower the axle.

Dual Pressure Axle Lift - HCV

Manual override knob detented air pressure shifts the valve (electric on = axle down)

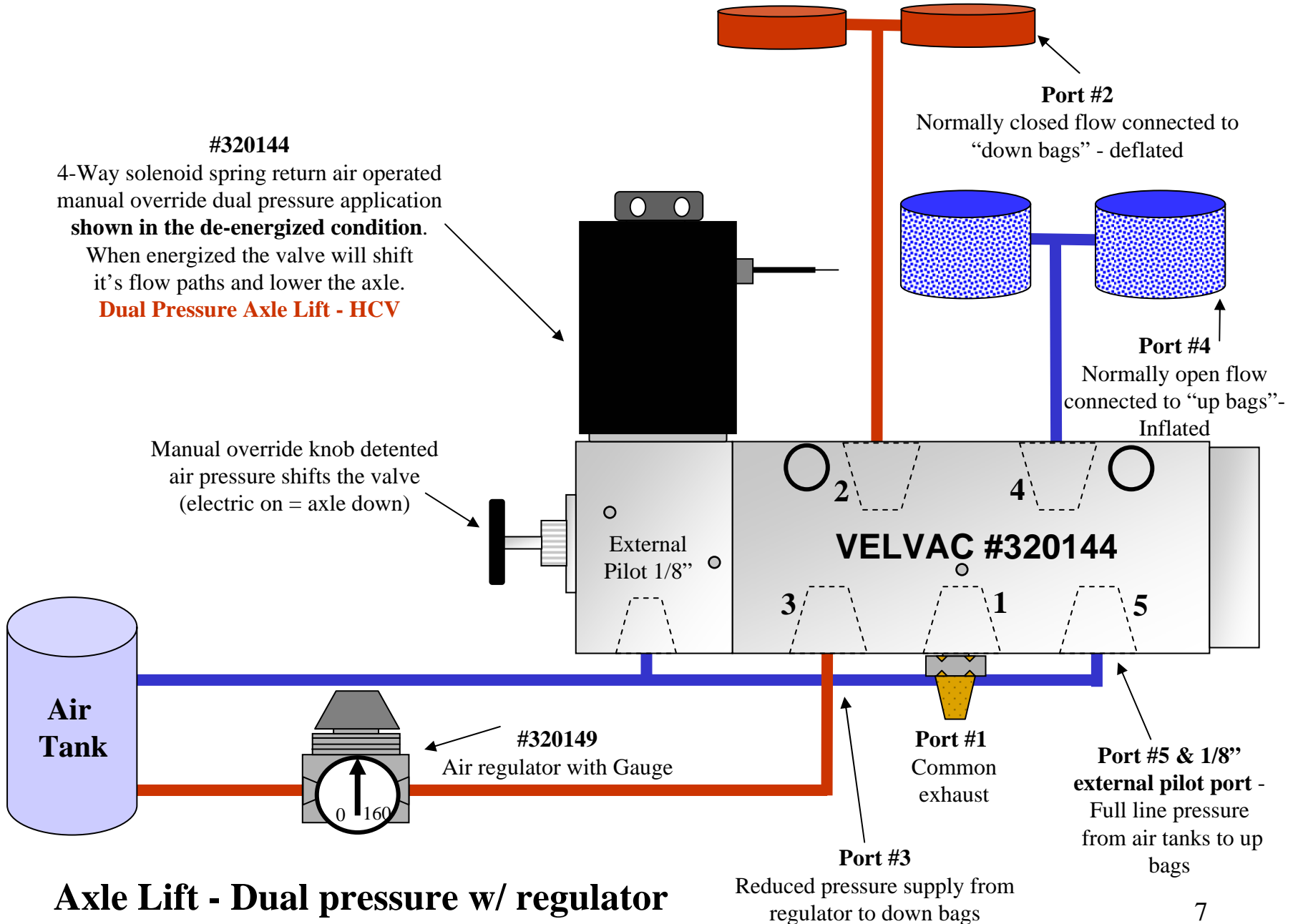

Axle Lift - Dual pressure w/ regulator

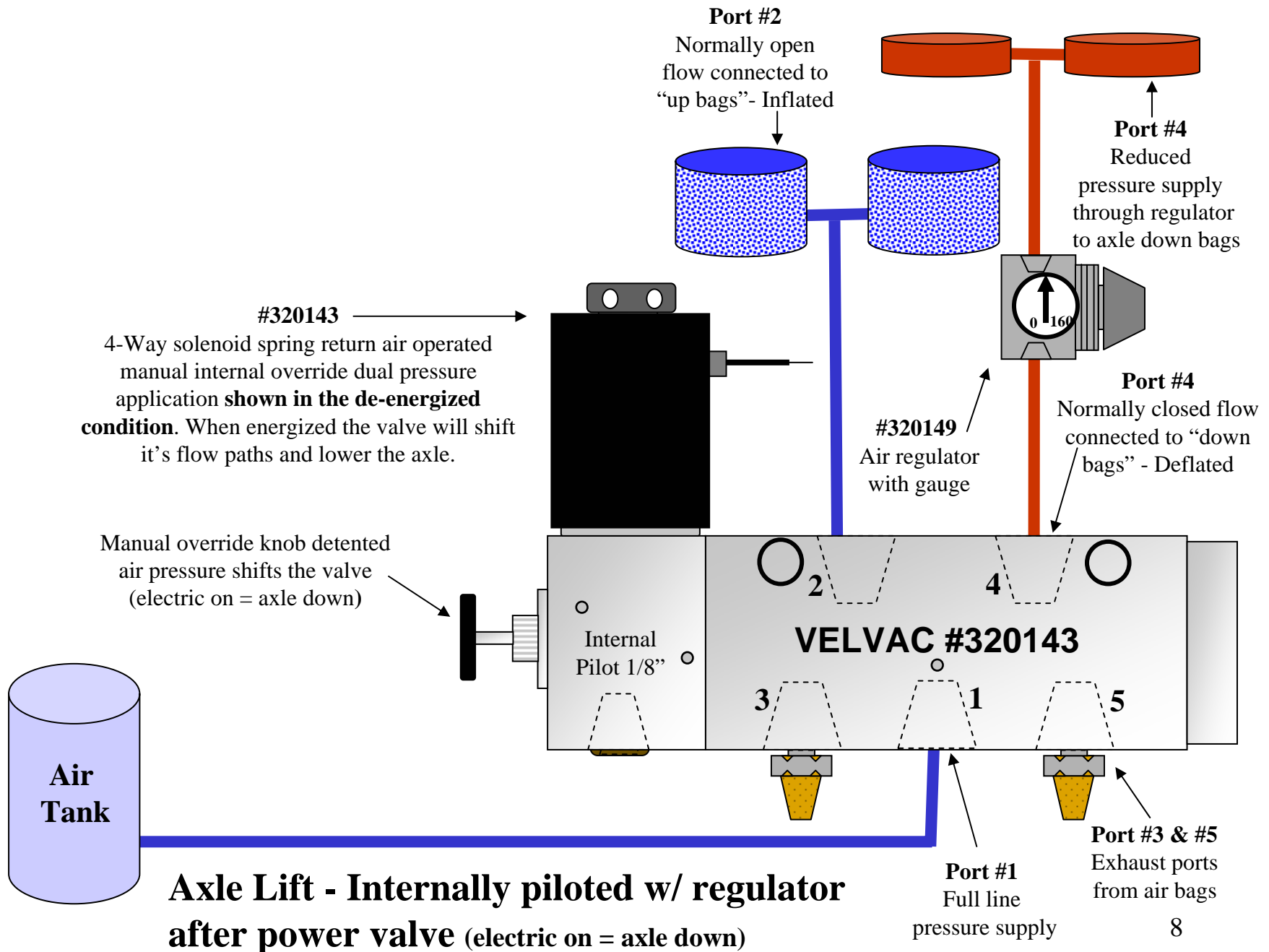

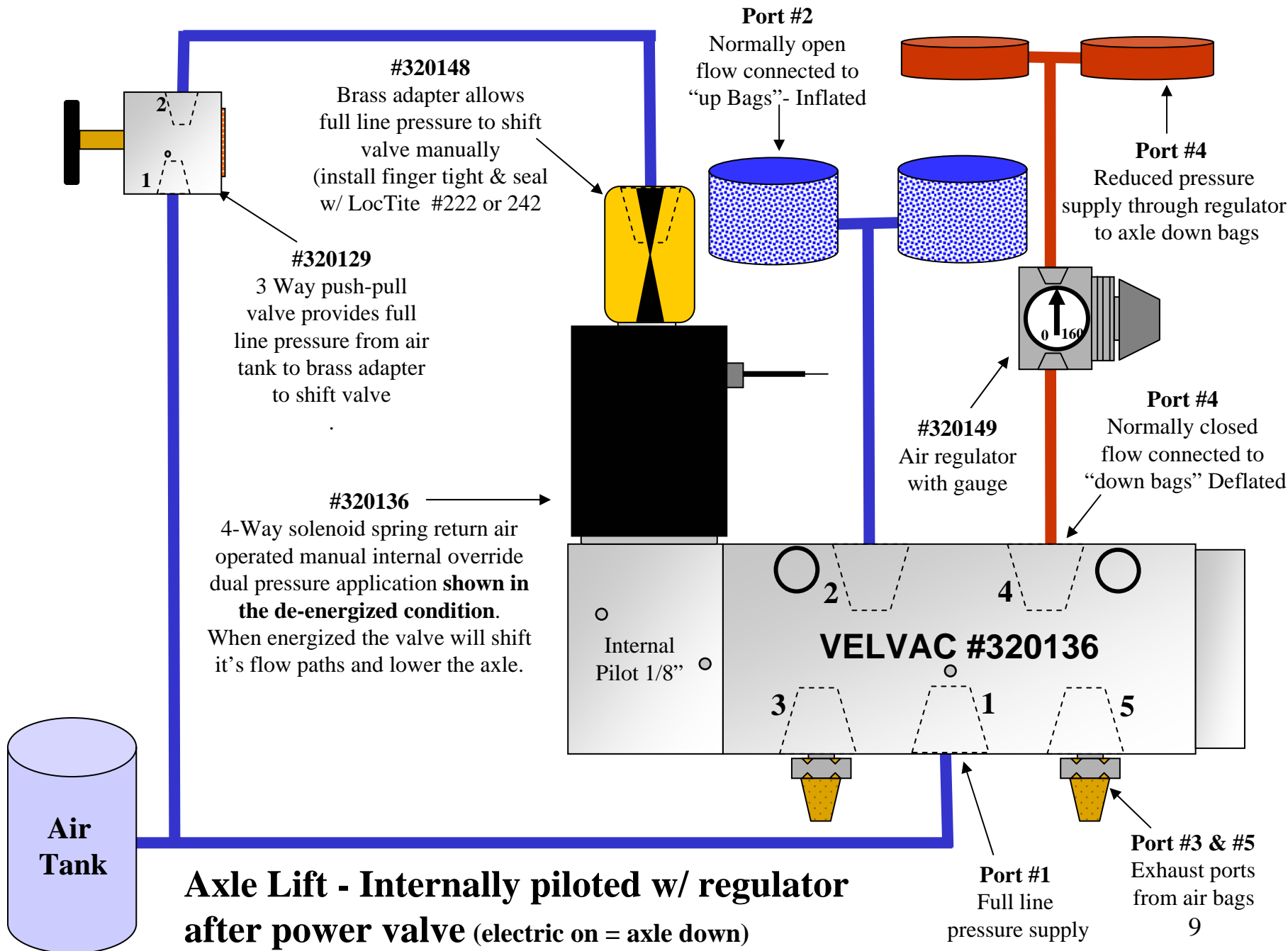

Axle Lift - Internally piloted w/ regulator after power valve (electric on = axle down)

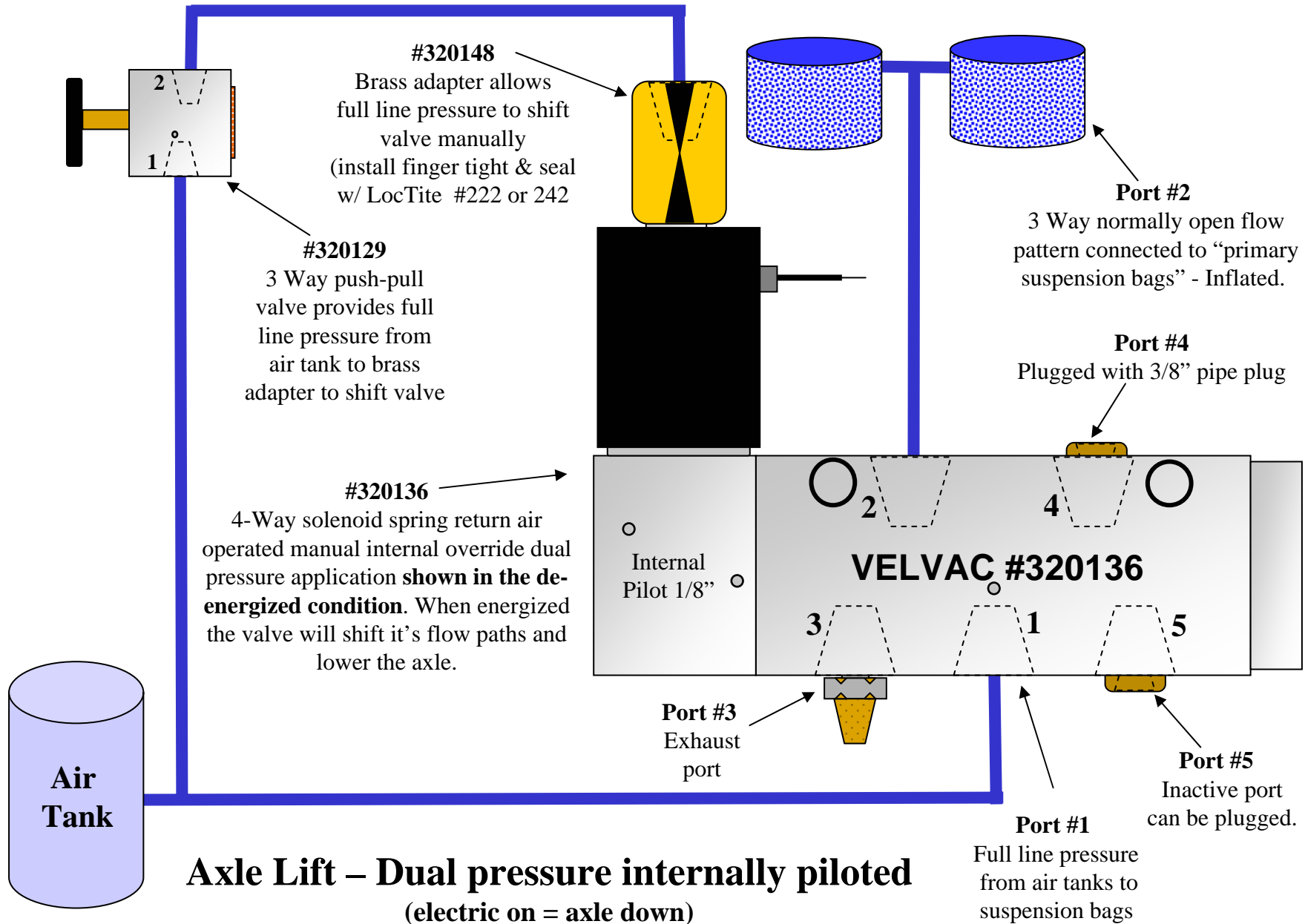

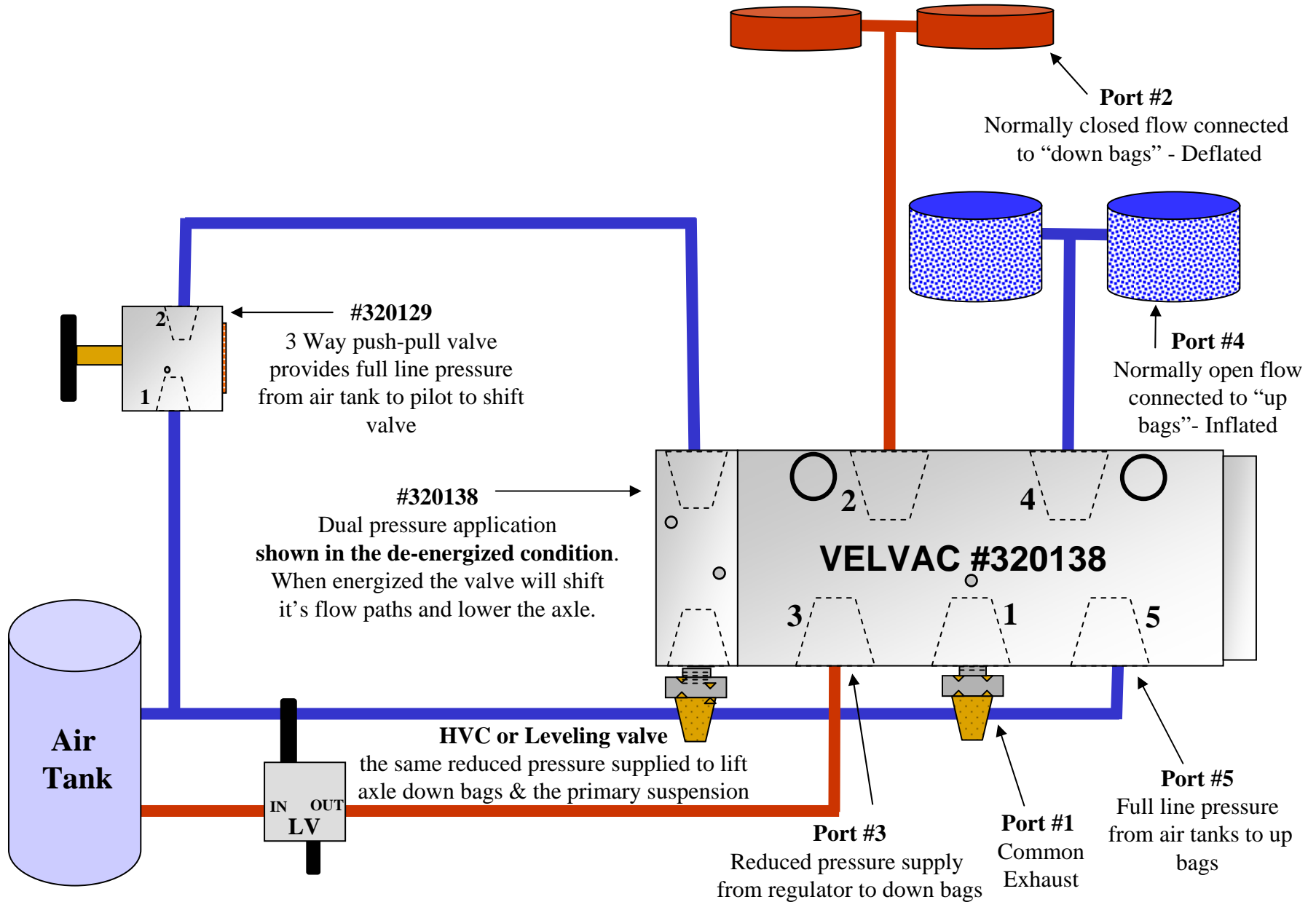

Axle Lift – Air piloted operated w/ leveling valve

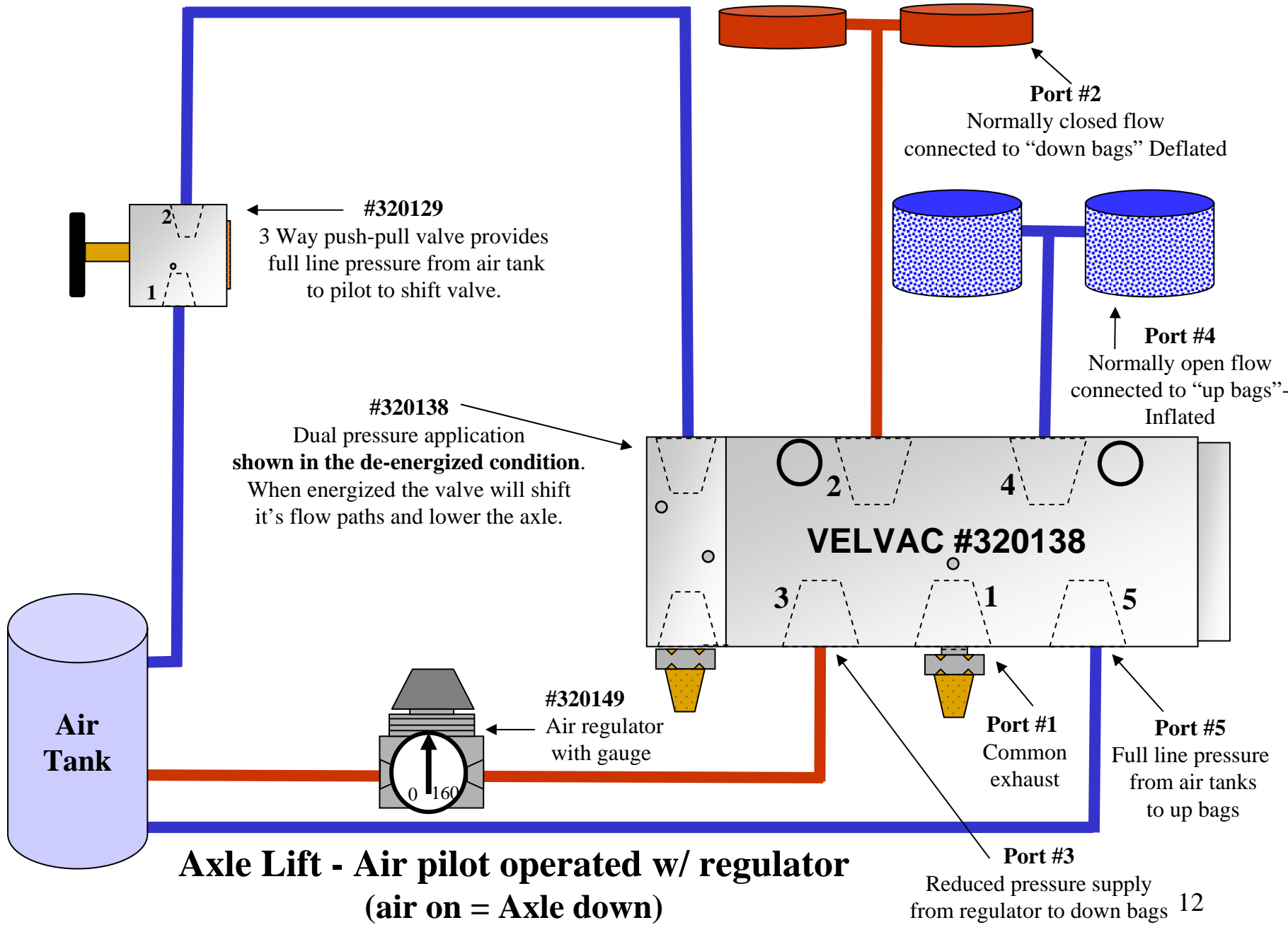

**Axle Lift - Air pilot operated w/ regulator
(air on = Axle down)**

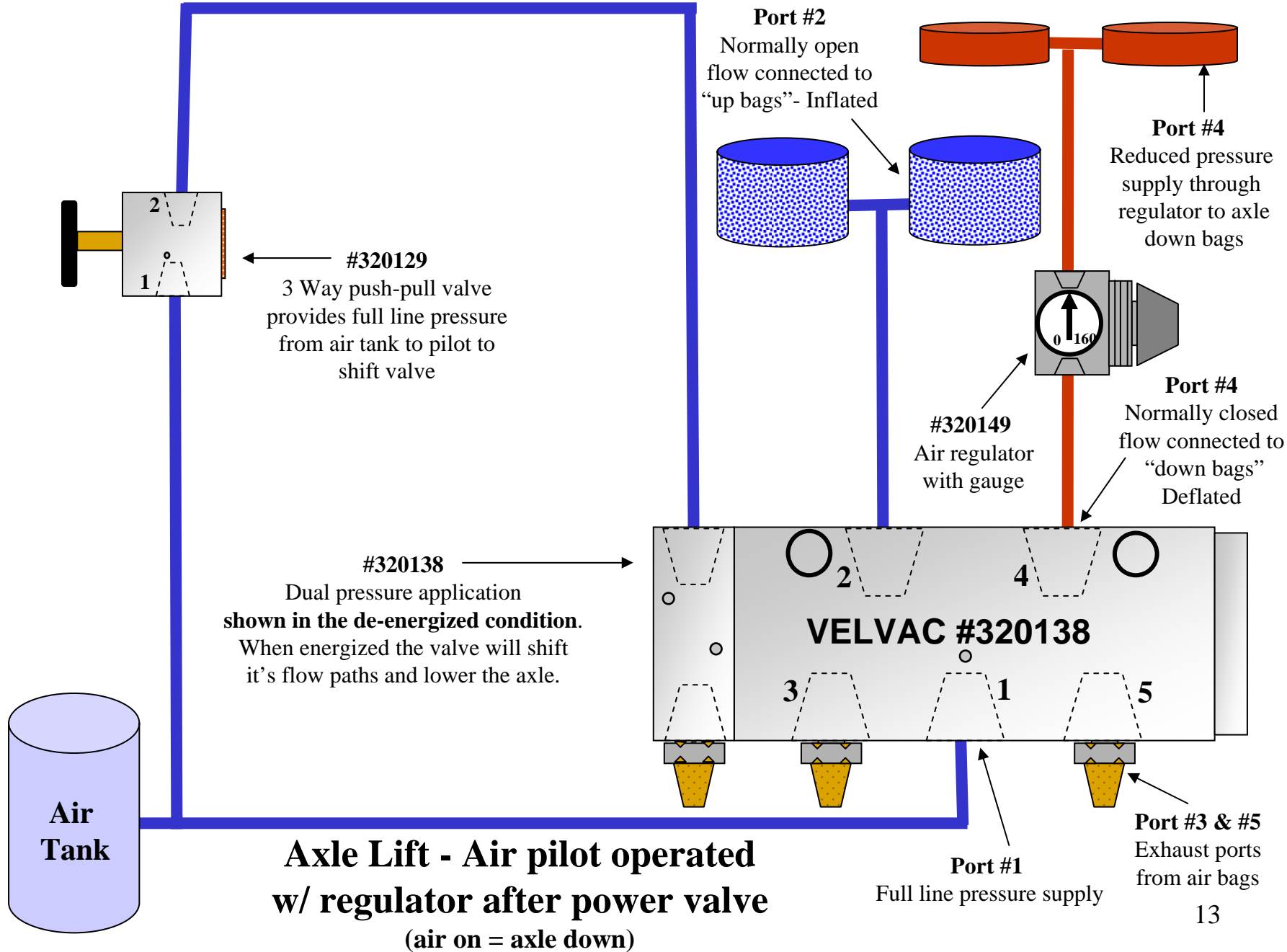

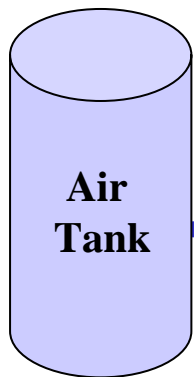

#320129
3 Way push-pull valve provides full line pressure from air tank to brass adapter to shift valve

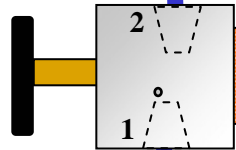

Port #2
Normally open flow connected to "up bags"- Inflated

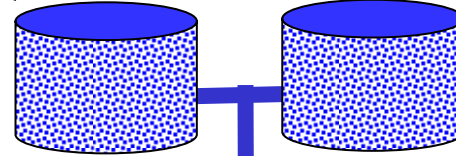

#320139
Dual pressure application shown in the de-energized condition. When energized the valve will shift it's flow paths and lower the axle.

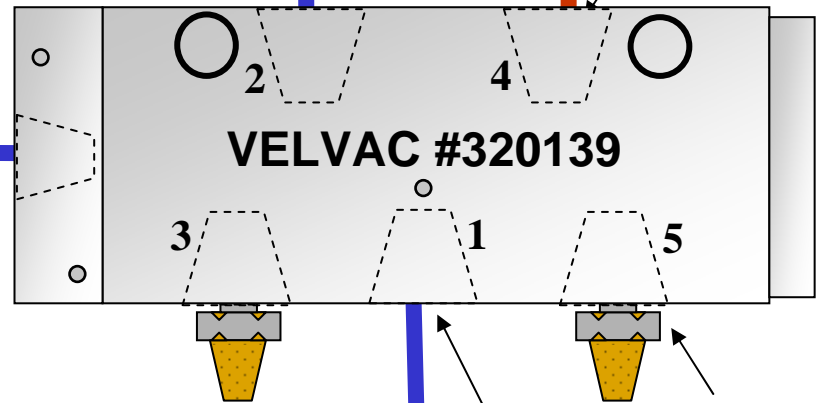

#320149
Air regulator with gauge

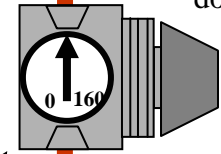

Port #4
Reduced Pressure supply through regulator to axle down bags



Port #4
Normally closed flow connected to "down Bags" Deflated

Axle Lift - Air pilot operated w/ regulator after power valve (air on = axle down)

Port #1
Full line pressure supply

Port #3 & #5
Exhaust ports from air bags

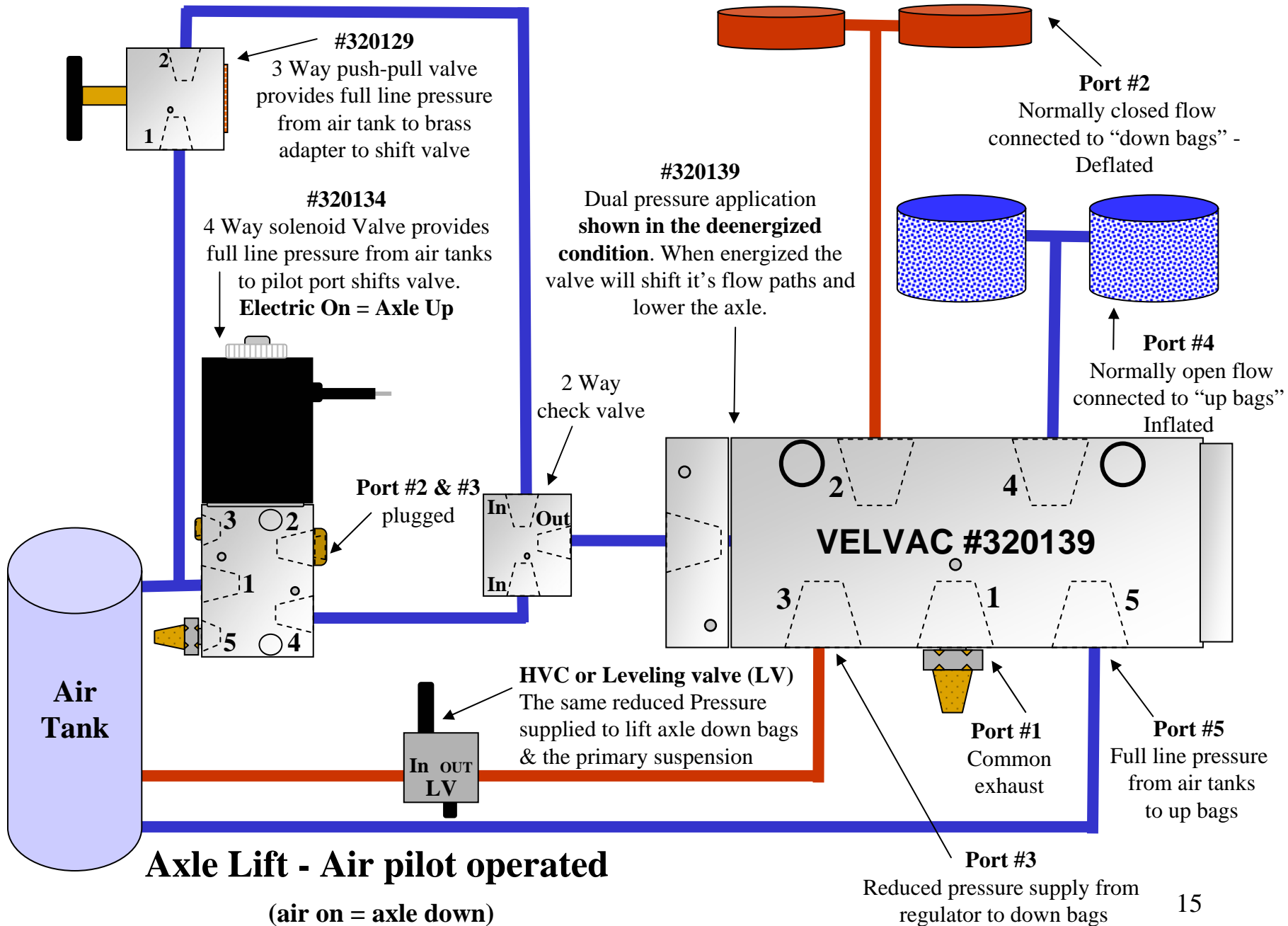

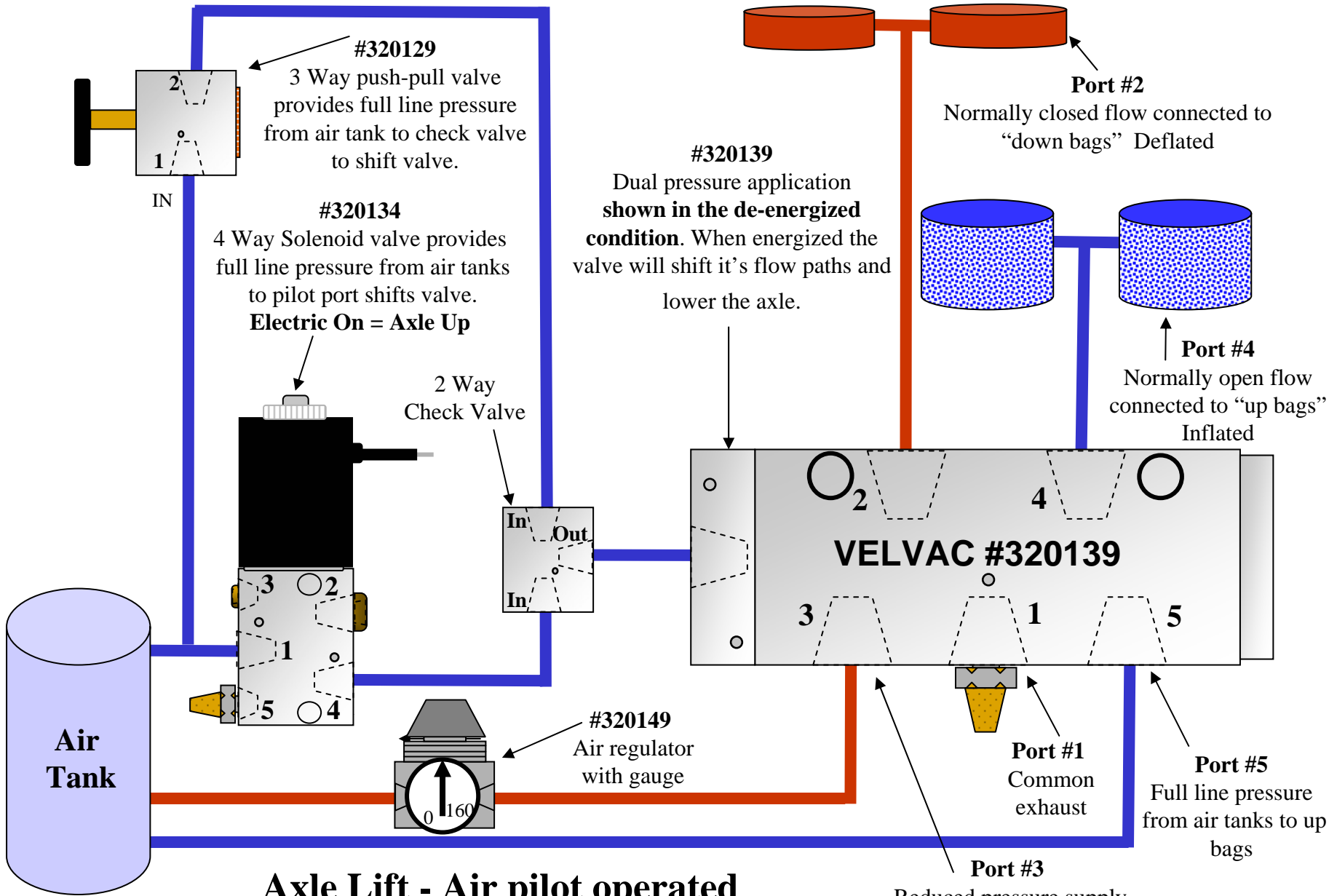

Axle Lift - Air pilot operated
(air on = axle down)

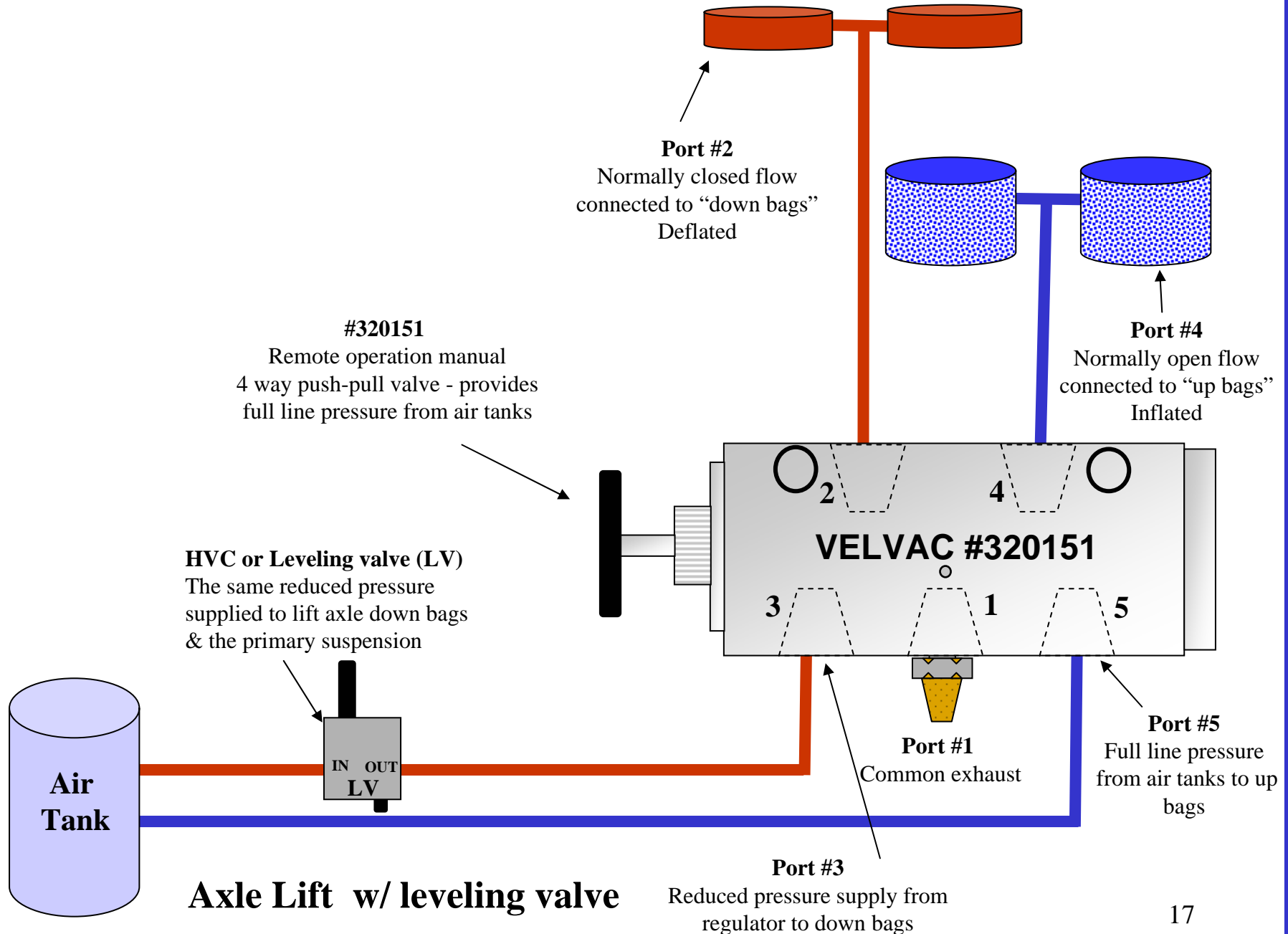

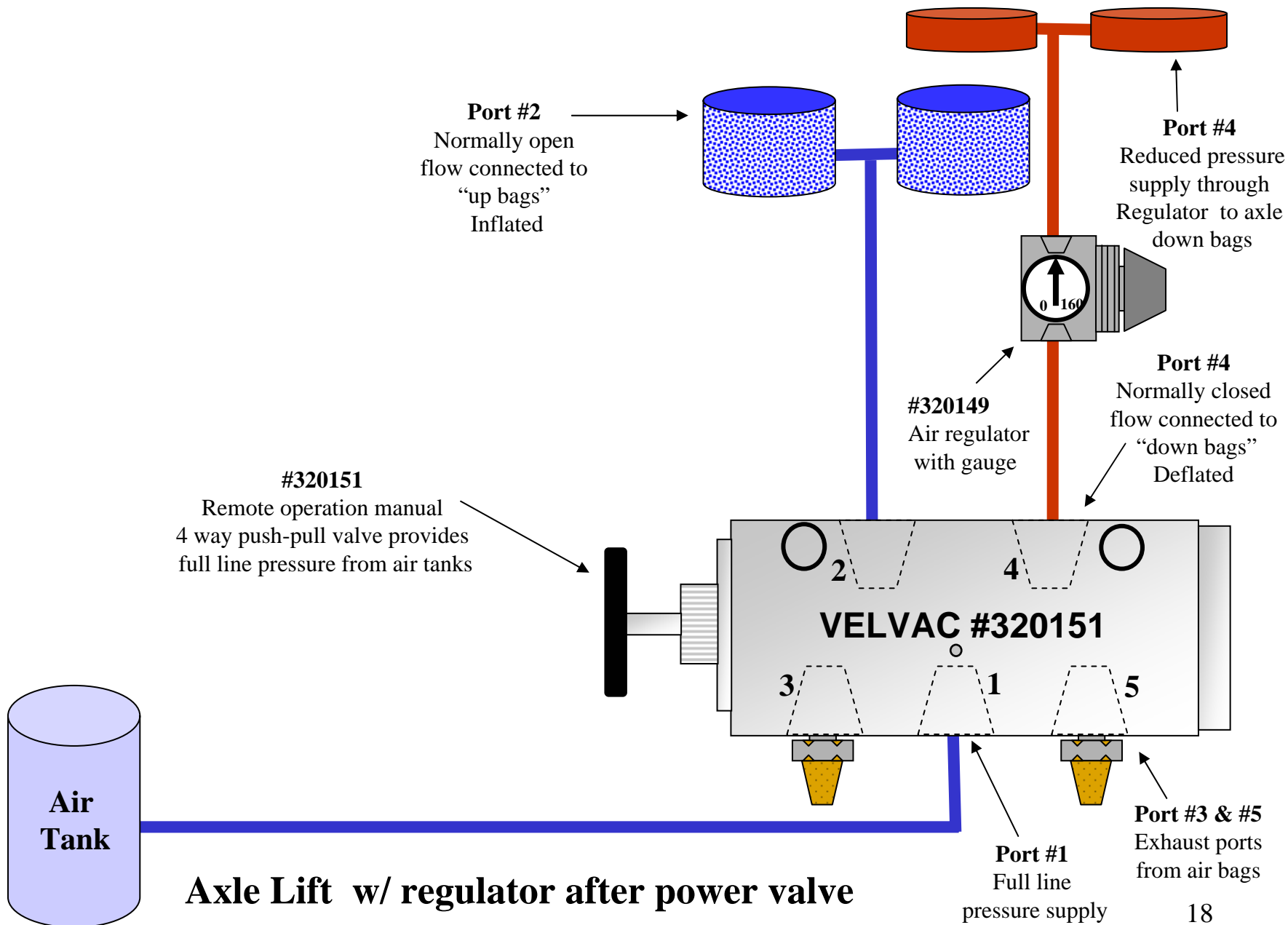

Axle Lift w/ regulator after power valve

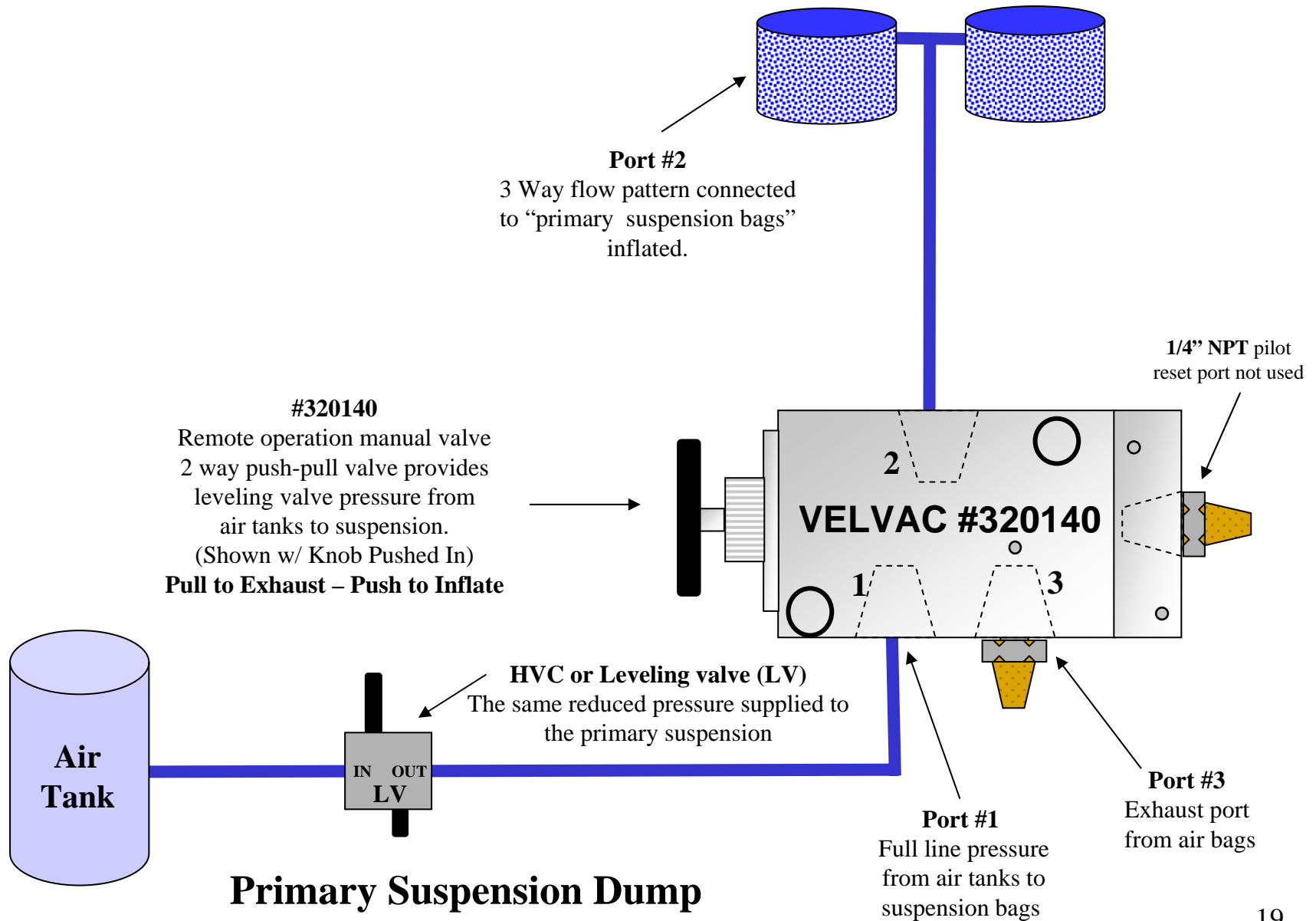

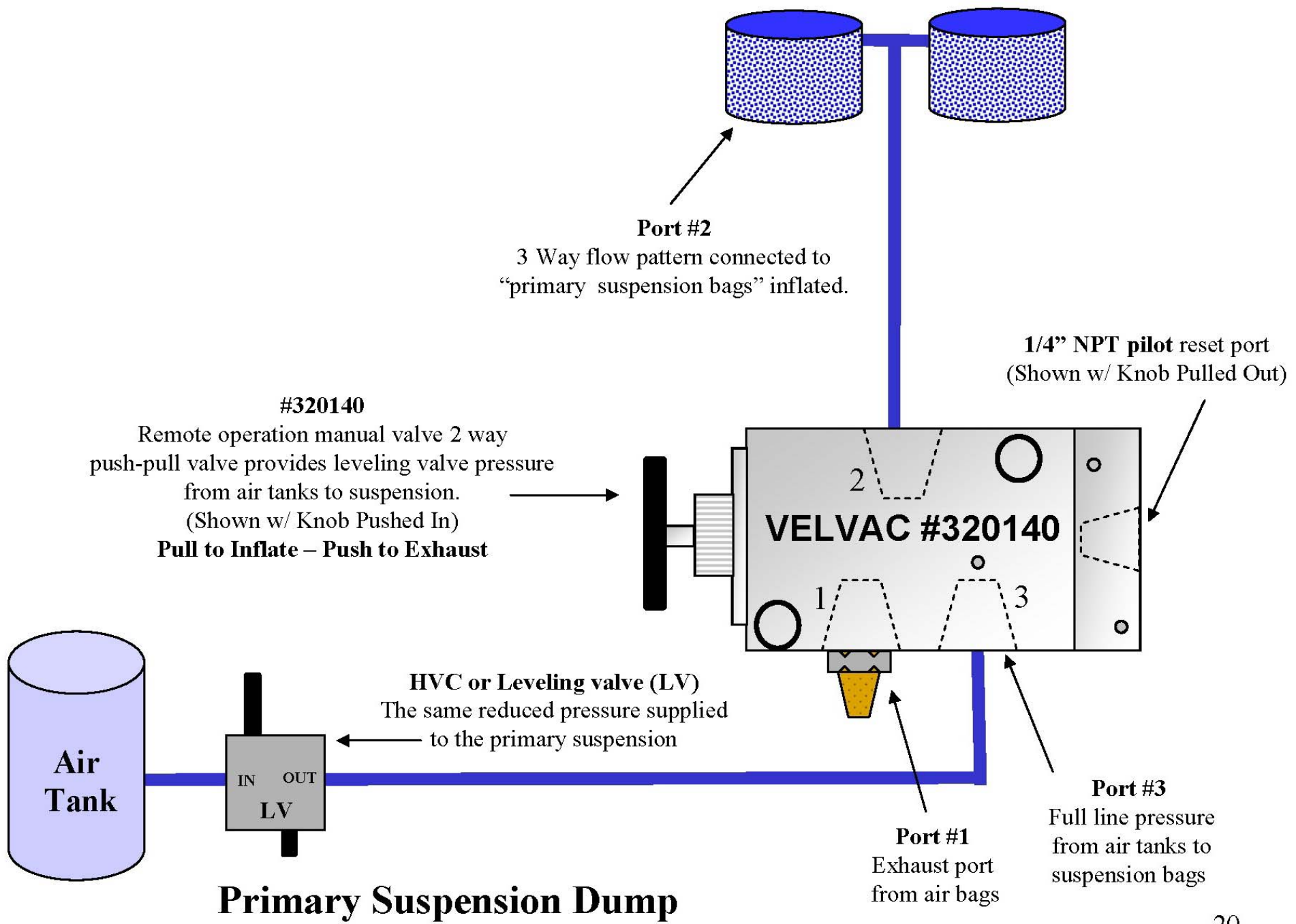

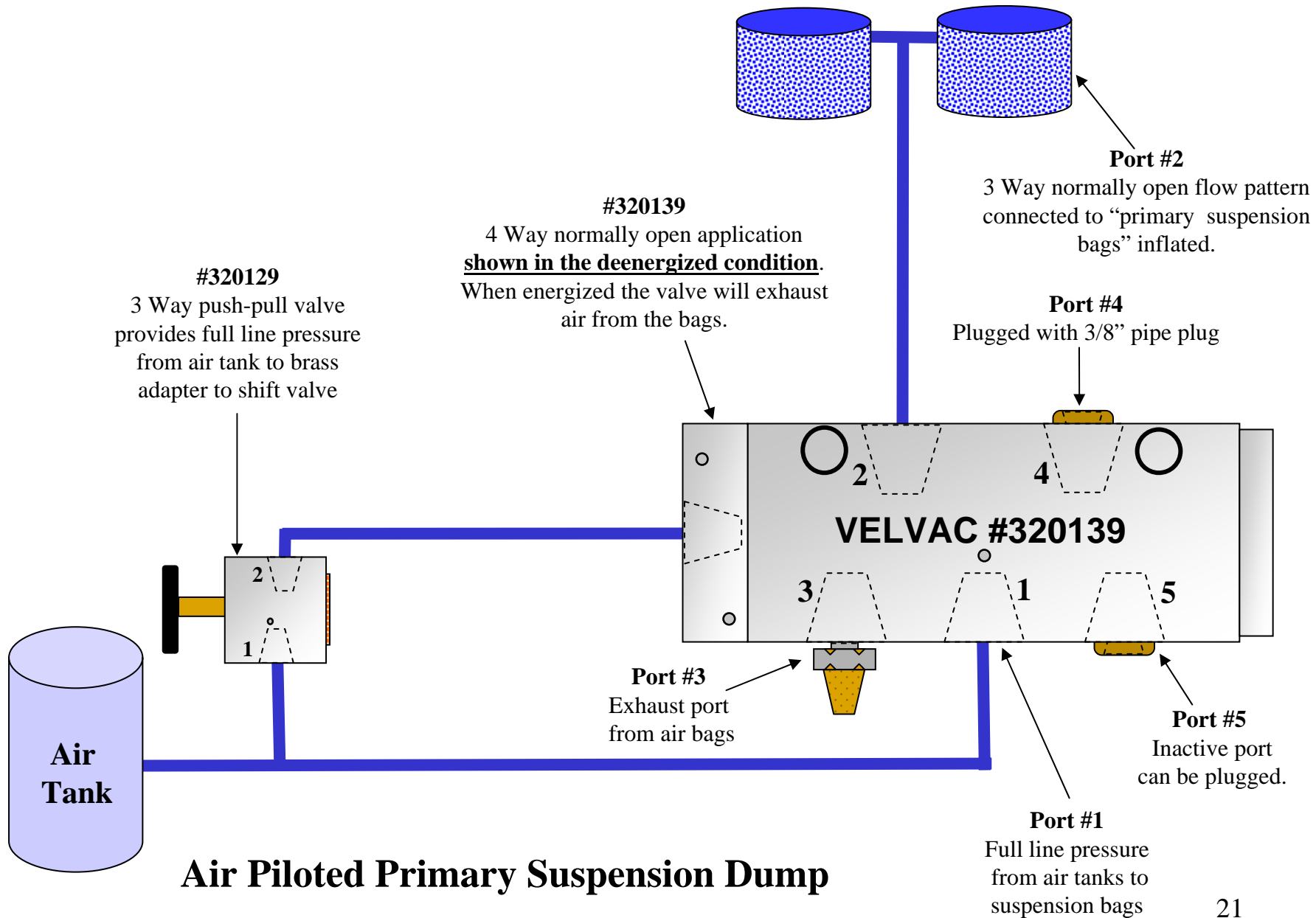

Air Piloted Primary Suspension Dump

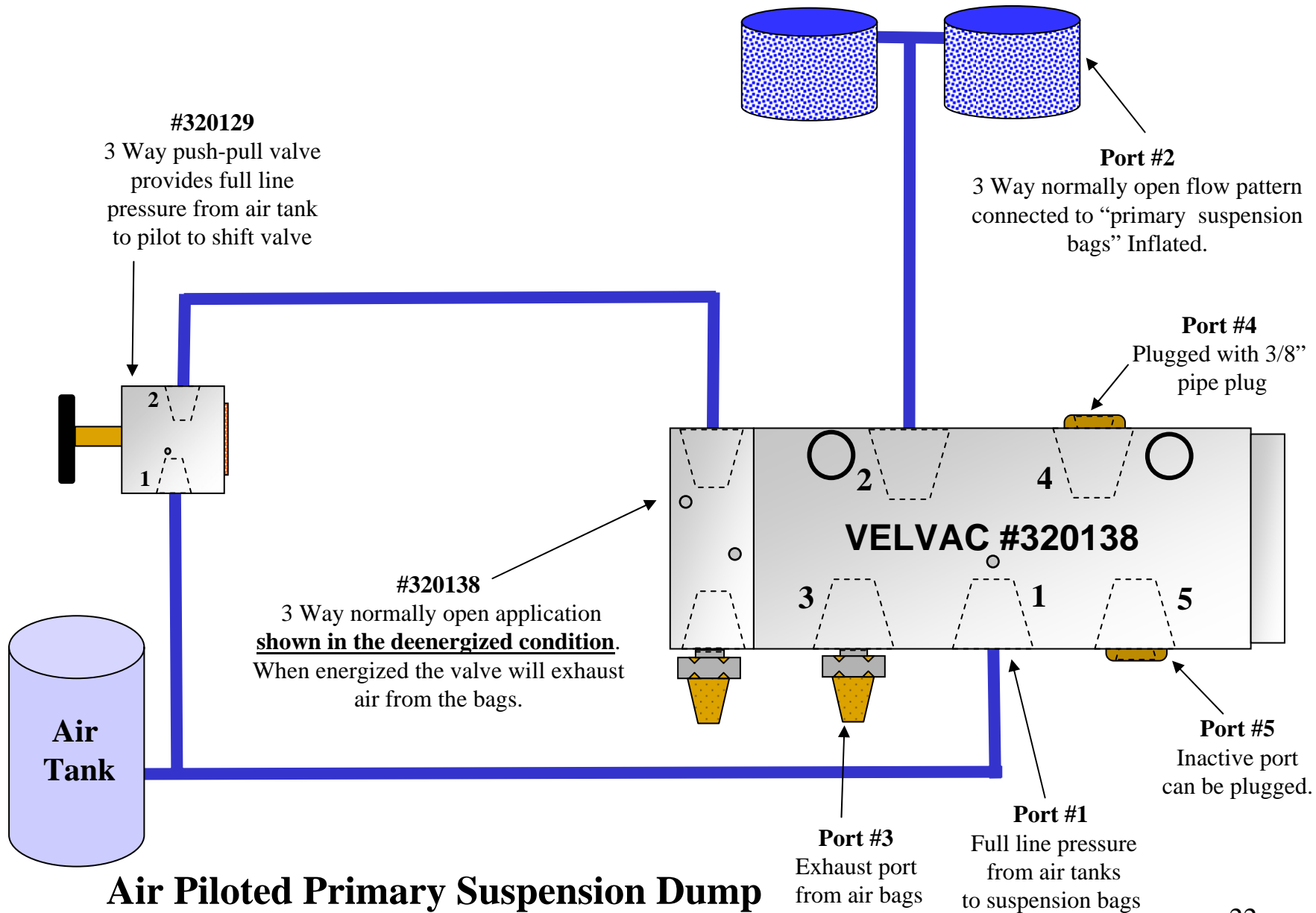

Air Piloted Primary Suspension Dump

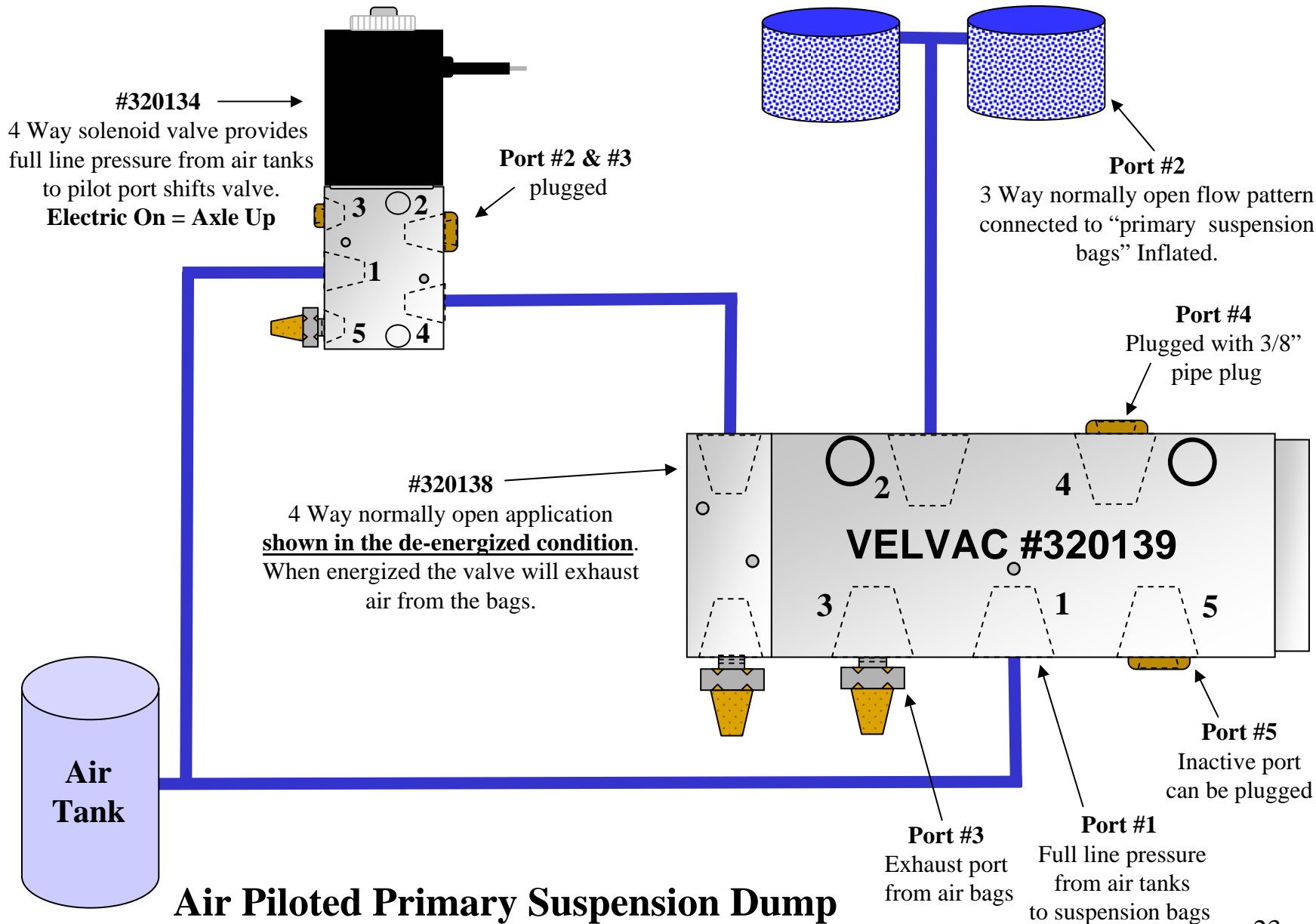

Air Piloted Primary Suspension Dump

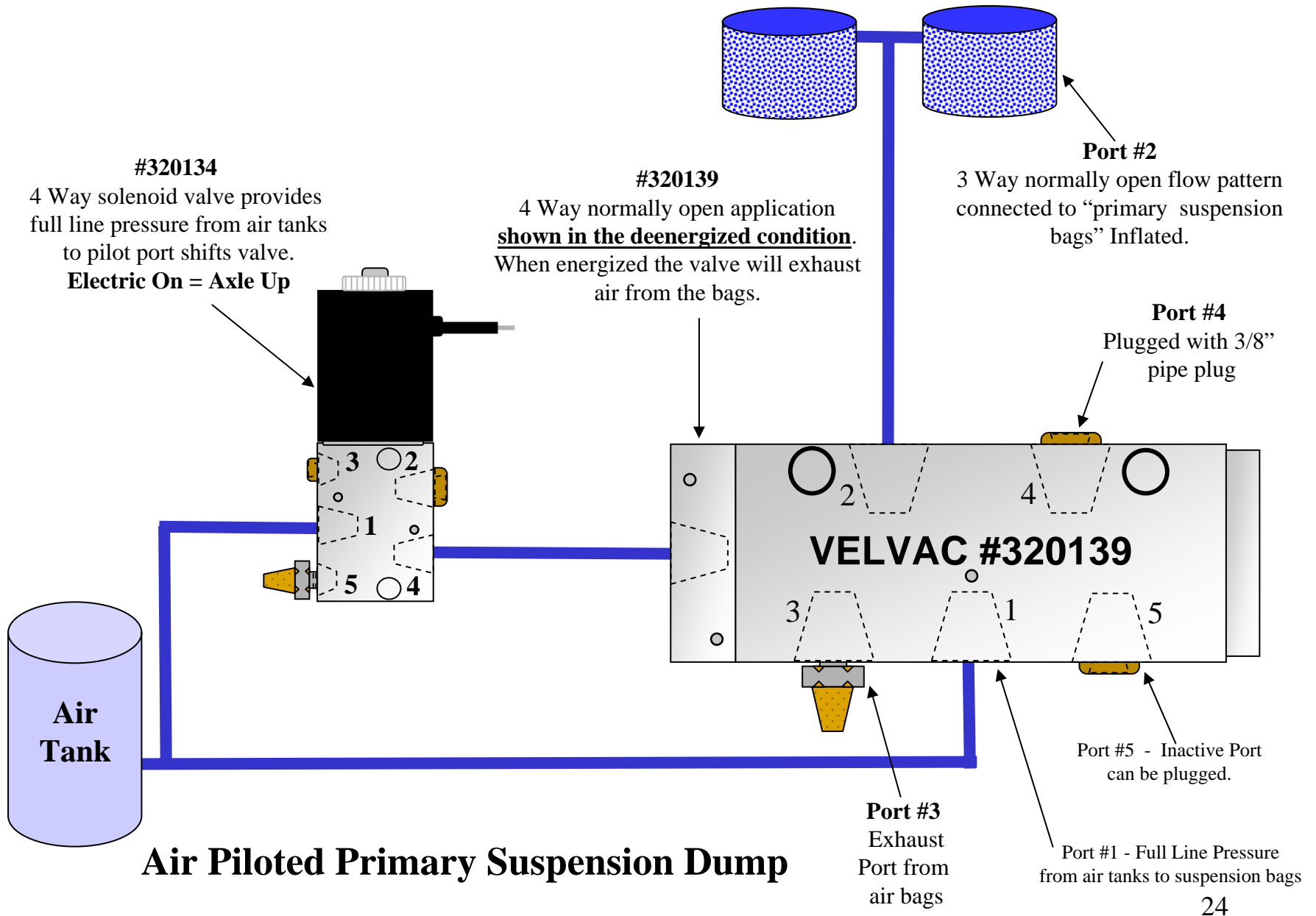

Air Piloted Primary Suspension Dump

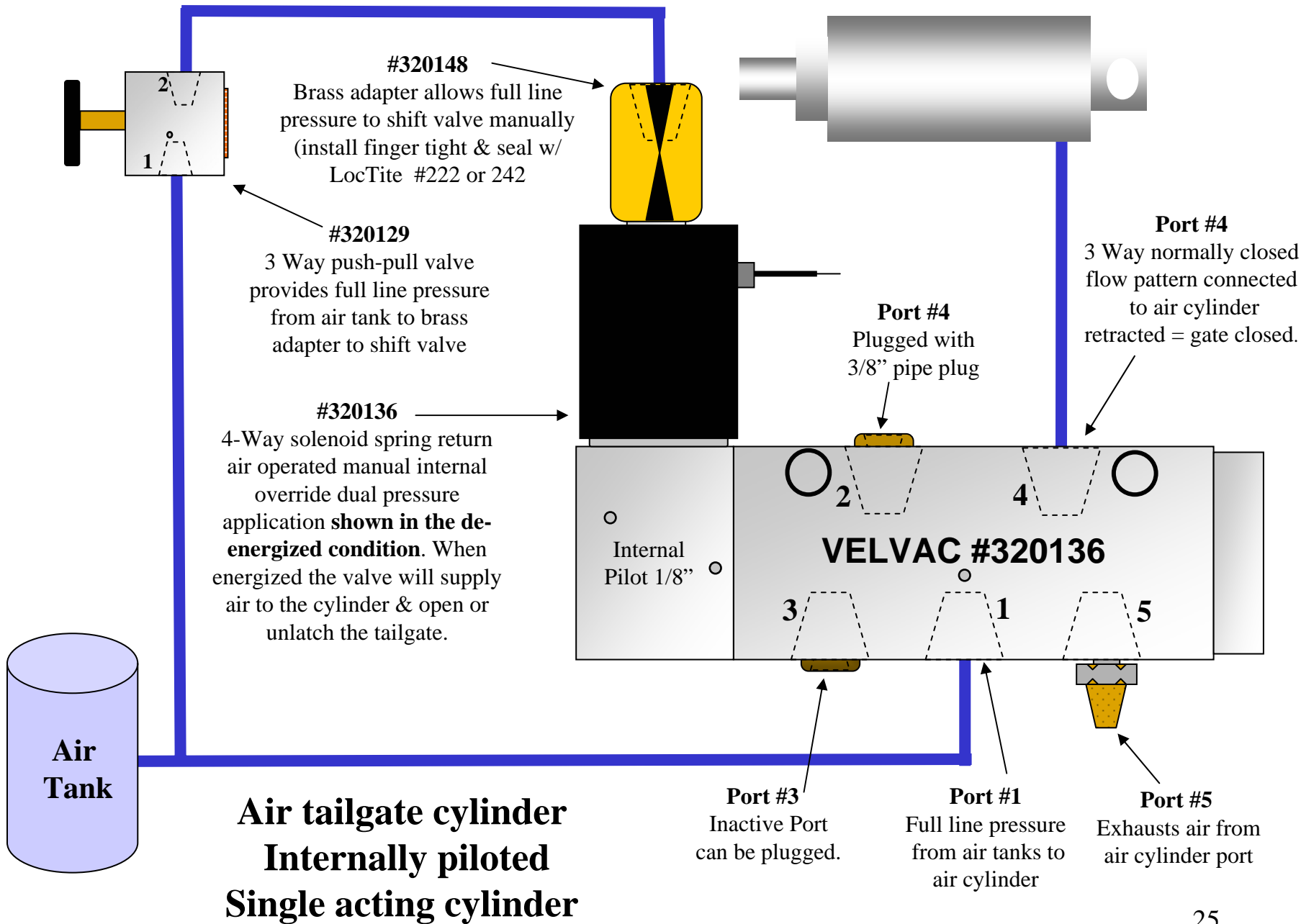

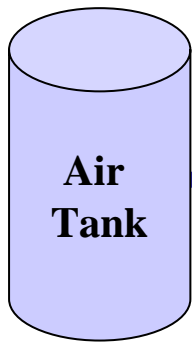

**Air tailgate cylinder
Single acting cylinder**

#32140
2 Way push pull
air piloted reset valve

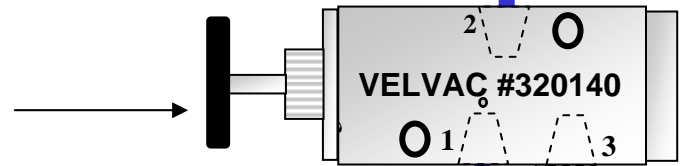

Port #1
Full line pressure
from air tanks to air cylinder

Port #3
Exhausts air from
air cylinder port



