

ATA *Adjustable
Torsion Axles*

**Tow
Zone™**

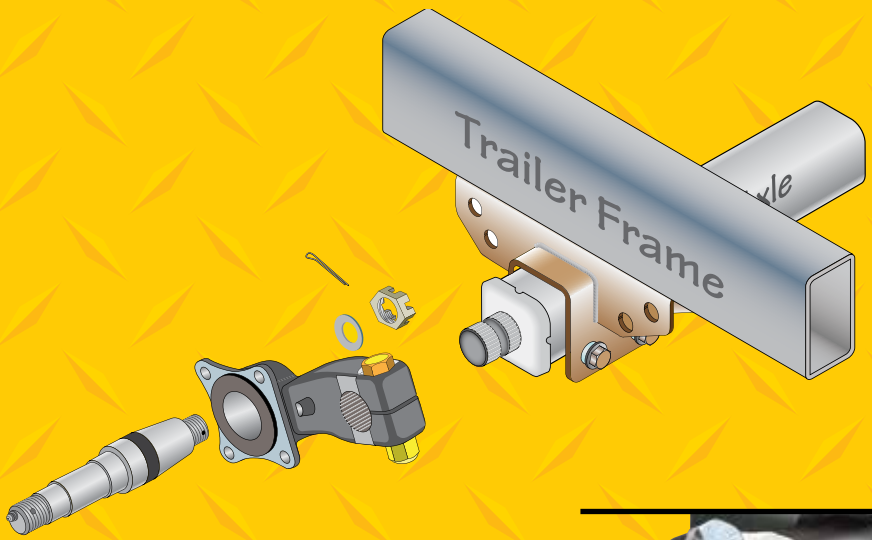

**Multi Adjustable
Splined Torsion Axle
Owner's Manual**



Adjustable Torsion Axles

Table of Contents	Page
Components of the Adjustable Torsion Axle System	3
Adjustable Torsion Axle Information	4-5
Deciding which Adjustable Torsion Axle is right for you	6
New Axle Placement/Installation of Weld-On Frame Mount	7
Axle Bracket Assembly	8
Installation of Adjustable Torsion Axle	9
Torsion Arm Assembly	10
Super Lube Wheel Hub/Spindle Operating Instructions	11

Congratulations on purchasing TIE DOWN ENGINEERINGS Adjustable Torsion Axle. The ATA (Adjustable Torsion Axle) can be adjusted in three ways.

It will only take you a few minutes to review the instructions and warnings. Please do so to be able to fully understand what you are doing BEFORE you start.

Warnings

Axle tube cannot be welded. Extreme heat will damage the inner rubber suspension, causing failure of the axle. The adjustable torsion axle can only be used with the mounting brackets built by Tie Down Engineering. Do not attempt to use any other bracket to mount the axle. Read and understand all instructions before starting work on your axle/trailer. Safety first, properly block and support your trailer before starting work on the axle.

TIE DOWN ENGINEERING
255 Villanova Drive SW, Atlanta, GA 30336
(404) 344-0000 • Fax (404) 349-0401

© 2015 TIE DOWN Inc., ALL RIGHTS RESERVED

Components of the Adjustable Torsion Axle System



Straight Axle



"V" Bend Axle

3750# Splined Torsion Axle Beams - Powder Coat Finish

Straight Axle Part Number	V-Bend Axle Part Number	Hub Face Length	Outside Frame Width Range	Brake Flange Length
86870	N/A	83.00	59-67	76.66
86871	86877	85.00	61-69	78.66
86872	86878	87.00	63-71	80.66
86873	86879	89.00	65-73	82.66
86874	86880	91.00	67-75	84.66
86875	86881	93.00	69-77	86.66
86876	86882	95.00	71-79	88.66



Adjustable Mounting Brackets - Powder Coat Finish

Part #	Description
86883	Utility Style Mounting Bracket - Powder Coat Finish, Right & Left Pair
86884	Weld-on Frame Mount for Utility Style Bracket (Unfinished), Right & Left Pair
86885	Marine Style Mounting Bracket - Powder Coat Finish, Right & Left Pair



1875# Splined Torsion Arm End Units - Powder Coat Finish

Part #	Description
86886	Torsion Arm, Quick Change Super Lube Spindle, Right & Left Pair
86887	Torsion Arm, Quick Change Super Lube Spindle, Idler Hub 545 (Painted), Right & Left Pair
86888	Torsion Arm, Quick Change Super Lube Spindle, Idler Hub 545 (GalvXL), Right & Left Pair

Adjustable Torsion Axle Information

Frame Size – The axle brackets can be adjusted to fit a certain frame width range for each length axle “G”.

Bracket Style – There are two types of brackets, Utility style “I” and Marine style “K”.

Torsion Arm Angle – “H” The torsion arms can be adjusted from 45 degrees down to 25 degrees up.

With these three adjustments, you can replace almost all custom torsion axles used today in the hub faces offered.

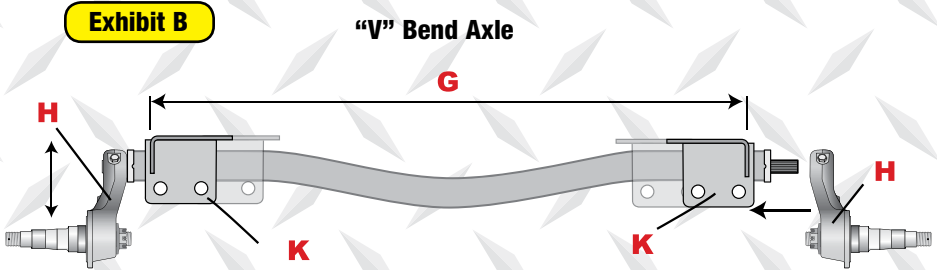
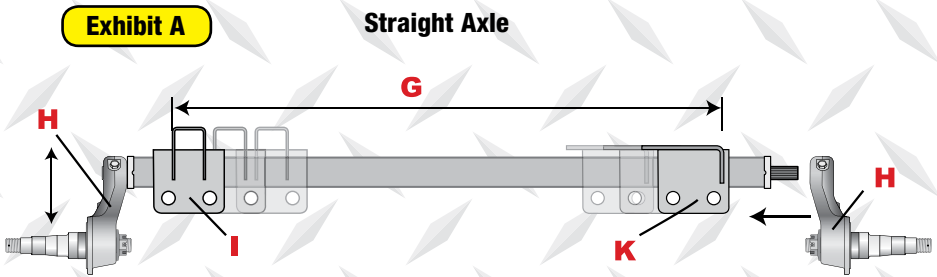

Adjustable Torsion Axle Information

Hub Face Width - Is measured from the face of the hub when properly assembled onto the axle spindle. Hub Face is NOT measured from the center of the tire. Hub face is NOT the overall length of the bare axle.

Track Width - Is a measurement from the center of the tires. This length can vary with the different types of wheels that offer varying offsets. Track is NOT the same as the hub face.

Brake Flange Width - Is measured from the outer surface of the flange to the same location on the opposite side of the axle.

Each axle length has its own range of positions for mounting the axle brackets. Do NOT exceed the range shown (see Exhibit C). Exceeding the overhang length will create camber and tire wear issues.

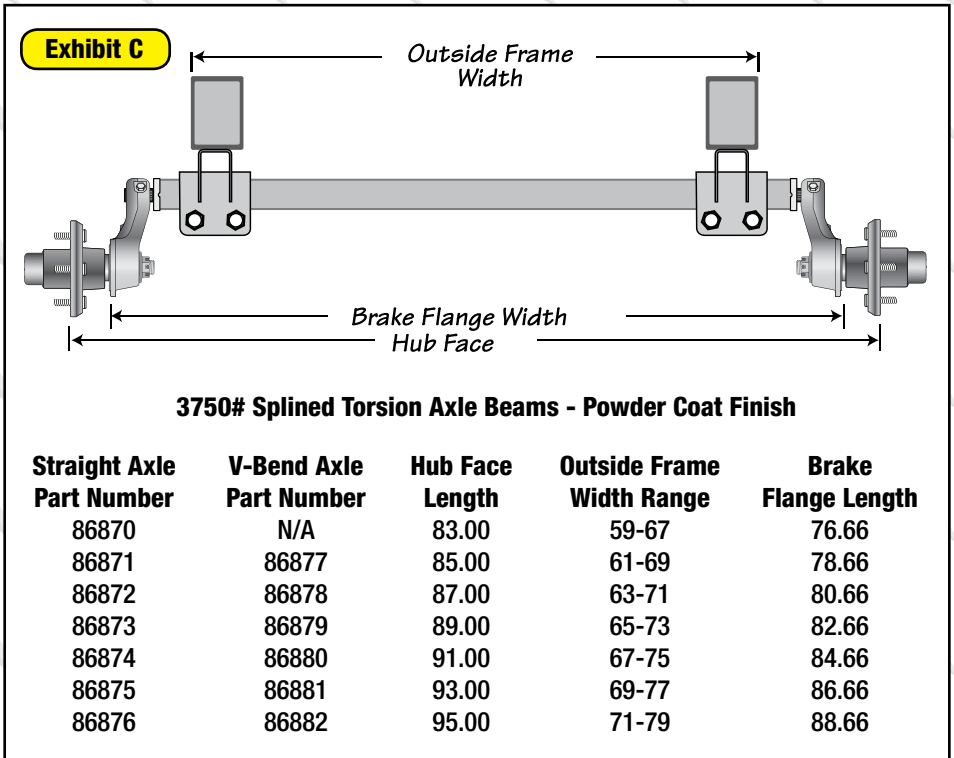

Deciding which ATA is right for you:

New Custom Trailer

1. Measure frame outside width, add 8 inches. This gives you the **MINIMUM Hub Face** you can use that allows for proper clearance of the torsion arm on each side. Wide tires or off set wheels could change this.
2. Review the different hub face lengths and their outside frame width range for axle bracket positions to verify which ATA will work on your custom frame width (see Exhibit C).
3. Decide on a straight axle tube or “V” bend axle tube.
4. Decide on bracket type, utility or marine style. Each offers different mounting options. If you choose utility, there are frame mount brackets that can be welded to the trailer frame to allow utility brackets to be bolted to the frame.

Replacing an Existing Torsion Axle

1. With the wheels off of the hubs, measure the hub face or brake flange width of the axle (see Exhibit A).
2. Measure the outside of the frame where the axle is to be mounted
3. Verify which ATA fits your application using the hub face, brake flange and outside frame measurements (see Exhibit C).
4. Verify which axle mounting brackets will be used, utility or marine.

NOTE: If you are replacing a spring axle, seek professional assistance as mounting centers and arm angle are different for spring and torsion axles.

WARNING BEFORE ASSEMBLY

1. Review all instructions once again!
2. Properly stabilize trailer with blocks or stands
3. If a rolling tongue jack is present. Block roller wheels

New Axle Placement/Installation of Weld-On Frame Mount

If you are using new frame brackets or welding the frame brackets to your trailer frame: **VERY IMPORTANT:** Brackets must be “square” to the frame. The frame brackets must be welded/attached at the same distance from the rear or front of the trailer. Failure to do so will result in a trailer that will travel at an angle when towed.

1. Weld-On Frame Mounts (#86884) must be installed directly across from each other to insure proper axle alignment. Before mounting the units, measure back from the coupler and mark the frame to make sure that the two distance measurements (A and B) are within 1/8 inch of each other. Mark the trailer frame for the location of the front edge of the frame mount.

Exhibit D

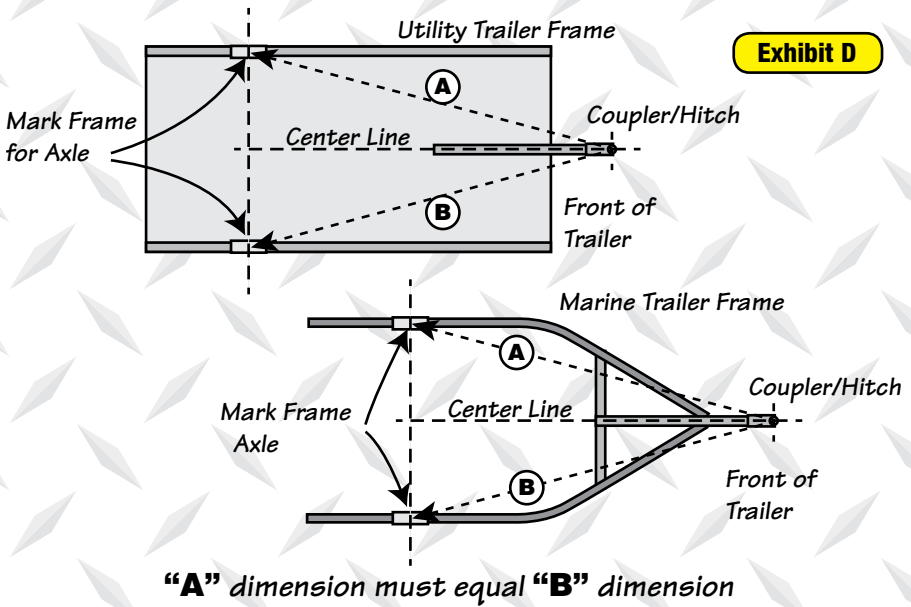

For more information about ATA Installation please visit:
www.tiedown.com/atainstall.html

2. Clamp the weld on bracket in place. The center line of the axle will line up with the center line determined by the coupler to axle measurement. Make sure the short end of the bracket is in the forward direction (See Exhibit E).

3. Weld a 1/4" fillet weld on all sides of the mounting bracket, repeat for other side.

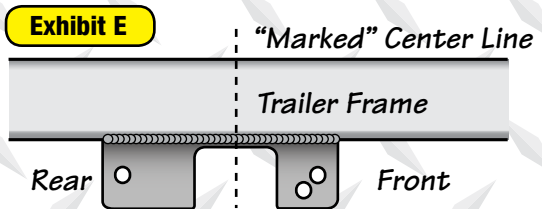

Axle Bracket Assembly

Read all instructions before starting assembly

Tools required: Socket, Ratchet & Torque Wrench

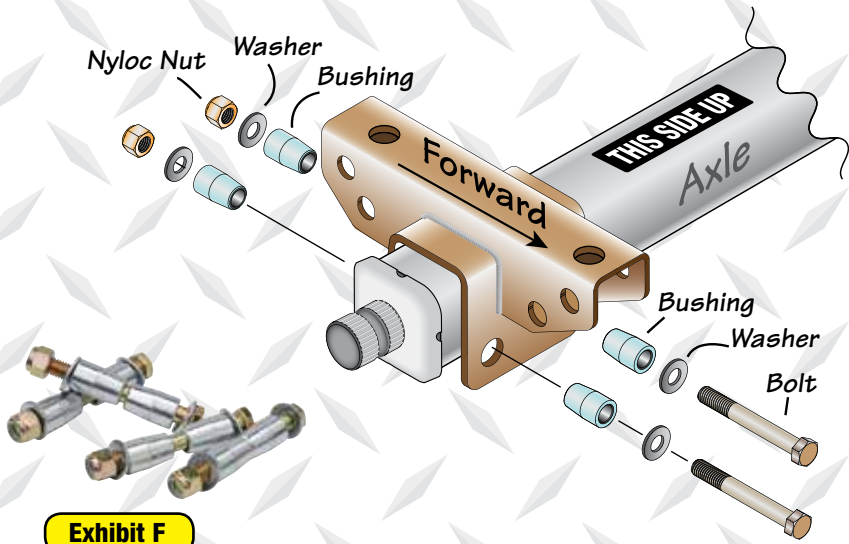

Exhibit F

1. Place the axle underneath the trailer, as close as possible to the mounting location. The following assembly will be preformed on the floor.
2. Position bracket on axle tube so that the short end of the bracket is facing forward. The rear (back) side of the axle has the identification decals
3. Using the hardware supplied (see Exhibit F), place a flat washer over one of the bolts. Next place one of the bushings on the bolt with the wider end facing the head of the bolt.
3. Insert the bolt with the bushing into housing so that the bolt goes under the axle and the threaded part is to the rear of the axle.
4. Insert one of the bushings onto the bolt with the narrow end facing the axle tube.
5. Place a flat washer on the bolt along with a nyloc nut. Snug the nut on to the bolt but **DO NOT TIGHTEN AT THIS TIME.**
6. Repeat for the second bolt.
7. Repeat for the opposite side bracket.

Installation of Adjustable Torsion Axle

CAUTION: These axles are very heavy. It is recommended to use floor jack to lift and position the axle to the frame. The following assembly requires at least two people.

If you are installing on a new trailer, skip to step 4.

1. Remove wheels and brake lines, if present, from the old torsion axle.
2. Remove torsion axle from the trailer.
3. Position the axle mounting brackets to match the existing axle brackets as closely as possible.
4. Using a floor jack and one other person, lift the axle into mounting position.

Utility Style Mounting Brackets:

- A. Bolt the axle to the frame using existing frame brackets.
- B. If frame mounting brackets are not present, but needed, welding of #86884 to frame will be required prior to mounting (see page 7). Using hardware supplied with #86884, bolt utility style mounting bracket to frame mount. Short end of the bracket should face the front of the trailer.

Marine Style Mounting Bracket:

- A. Tube or Channel Trailer Frame - Mount using two U-bolts for each bracket (as shown in Exhibit I). U-bolts must be a minimum of 1/2" diameter.
- B. I-Beam Trailer Frame – Mount using four 1/2" bolts through holes drilled in bottom web of I-beam (as shown in Exhibit H).

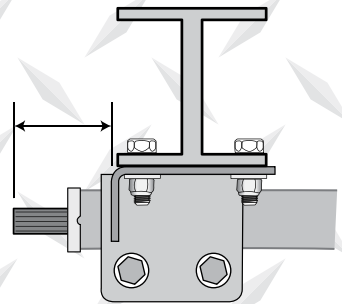
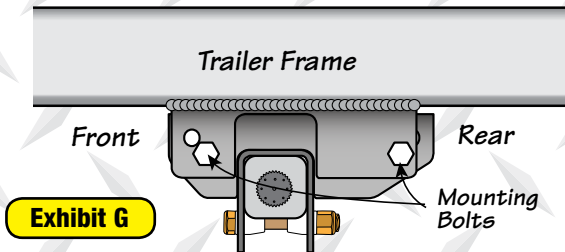

5. Center the ATA to the trailer frame. Measure the distance between the outside of the bracket to the end of the splined arm (Exhibit H & I). Distance must be equal on each side. **DO NOT USE THE AXLE TUBE AS A MEASURING POINT.**
6. Tighten the mounting bolts to the frame first. 150 ft lbs.
7. Re-check measurements on centering the axle on the frame.
8. Tighten the axle mounting brackets to 100 ft lbs.

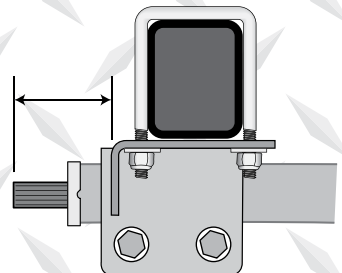

Torsion Arm Assembly

1. It is important to match as close as possible the same arm angle as the original axle. The variation possible is 45 degrees down to 25 degrees up. The end of the splined arm has index marks in a circular pattern (Exhibit J). Use these to line up with the gap in the torsion arm to assure that you have both sides set at the same arm angle. Arm angle can only be used in a “trailing” position, going towards the rear of the trailer.

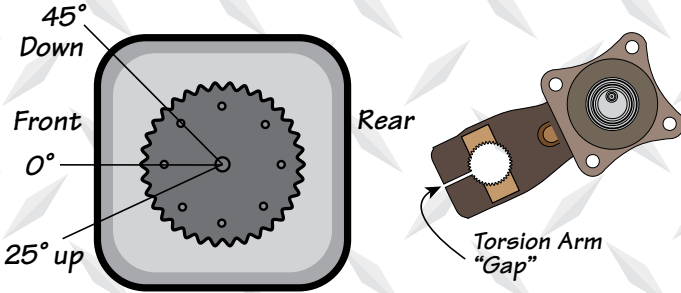

Exhibit J

Torsion arm shown in the 25 degree up angle

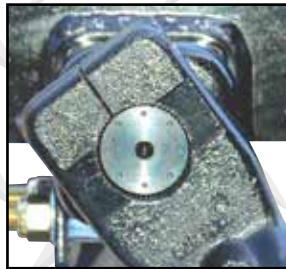

Exhibit K

Torsion arm shown in the 45 degree down angle

2. Insert the torsion arm bolt and nyloc nut, Bolt head should be in the upper or top of the arm position (Exhibit L). Torque to 150 ft lbs.

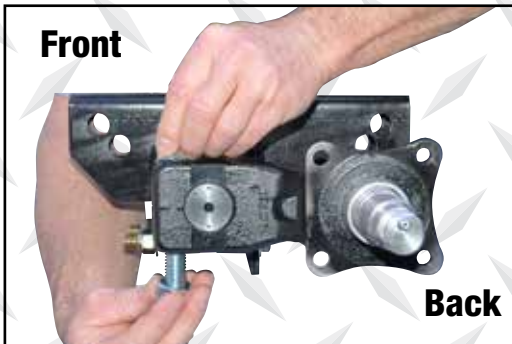

Exhibit L

Torsion arm shown in the 0 degree angle

Super Lube Wheel Hub/Spindle Operating Instructions

1. Remove wheel hubs from the packaging. Hubs are already pre-assembled and pre-greased.
2. Slide hub onto spindle, followed by washer and spindle nut.
3. Tighten the spindle nut to approximately 40 ft. lbs. Turn wheel in both directions to be sure wheel turns freely.
4. Turn back spindle nut 1/6 to 1/4 turn to the nearest locking hole. Hub should turn smoothly with no end play or wobble.
5. Line up cotter key with nearest locking hole and spread key.
6. Install the Super Lube dust cap and mount wheel.

The Adjustable Torsion Axle is equipped with Super Lube Spindles. These spindles allow for easy adding or replacement of grease in the wheel hub. The hubs are pre-greased with Lucas "Red n' Tacky" grease and assembled at the factory.

Super Lube "Spindle" Lubrication Maintenance or Grease Replacement

1. Remove the rubber plug from the grease (hub) cap (Exhibit M).
2. Use a standard grease gun onto the grease fitting located at the end of the spindle, making sure the grease gun nozzle is engaged on the fitting tightly.
3. Pump grease into the fitting, while slowly turning the wheel. Grease will flow out of the hub around the spindle.
4. When the grease appears to be the new clean grease, remove the grease gun and wipe off any excess grease.
5. Replace the rubber plug in the cap.

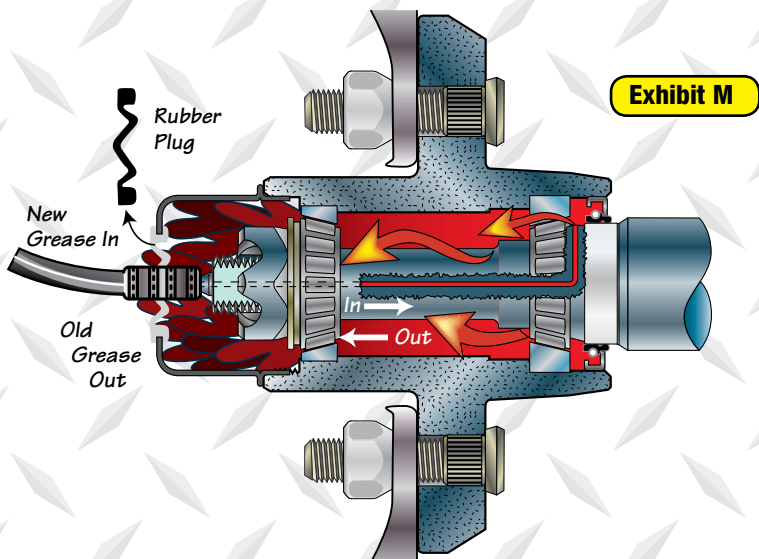



Multi Adjustable Splined Torsion Axle Owner's Manual

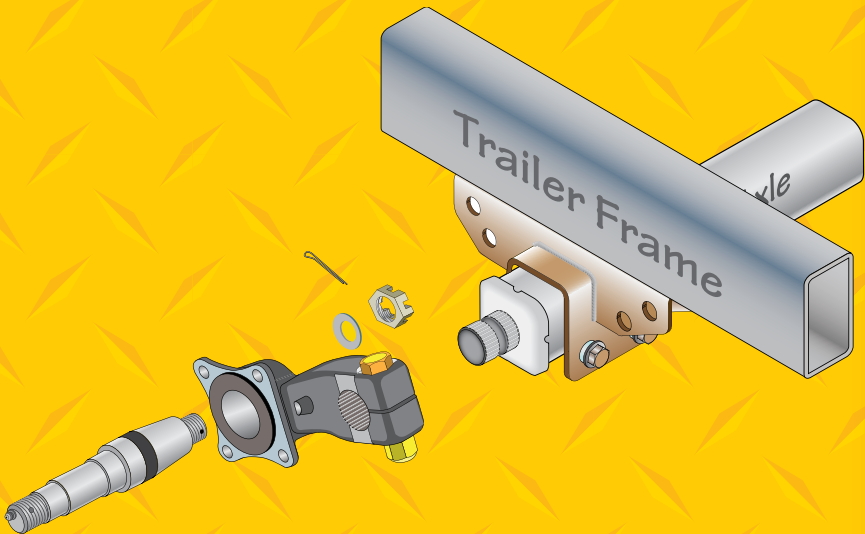

TIE DOWN ENGINEERING

255 Villanova Drive SW • Atlanta, Georgia 30336
800-241-1806 • 404-344-0000 • Fax 404-349-0401

ISO 9001:2008 Certification

Trade, brand, names and drawings are the intellectual
property of TIE DOWN ENGINEERING.

©2015 TIE DOWN, Inc.

Manual #08242 (Rev. 6/12/15)