



Demco

Brakes

13" x 2 1/2"



ASSEMBLY
CALIBRATION
OPERATION
REPLACEMENT PARTS

READ complete manual CAREFULLY
BEFORE attempting operation.

Doing Our Best to Provide You the Best

OPERATORS MANUAL

 **WARNING: To Prevent Serious Injury or Death**

FAILURE TO FOLLOW THESE INSTRUCTIONS, OR FAILURE TO PROPERLY MAINTAIN BRAKES AFTER INSTALLATION, CAN RESULT IN LOSS OF BRAKING ACTION. THIS CAN CAUSE PERSONAL INJURY, DEATH OR PROPERTY DAMAGE. ONLY PROFESSIONAL MECHANICS SHOULD INSTALL BRAKE CLUSTERS. HAVE YOUR BRAKES INSPECTED BY A PROFESSIONAL MECHANIC AT LEAST ANNUALLY AFTER INSTALLATION.

 **WARNING: To Prevent Serious Injury or Death**

- Review following instructions before installation and use of hydraulic brakes.
- Dealers or distributors must review these instructions with ultimate user.
- Failure to follow these instructions, or failure to properly maintain braking system after installation, can result in loss of braking action.

Table of Contents

General information.....	2
Safety, Signal Words	3
Bolt Torque	4
Installation and Maintenance	5-6
13" Brake Cluster Breakdown and Parts List	7
13" Brake Drum Comparison Chart.....	8

SAFETY

TAKE NOTE! THIS SAFETY ALERT SYMBOL FOUND THROUGHOUT THIS MANUAL IS USED TO CALL YOUR ATTENTION TO INSTRUCTIONS INVOLVING YOUR PERSONAL SAFETY AND SAFETY OF OTHERS. FAILURE TO FOLLOW THESE INSTRUCTIONS CAN RESULT IN INJURY OR DEATH.



THIS SYMBOL MEANS

ATTENTION

BECOME ALERT

YOUR SAFETY IS INVOLVED!

SIGNAL WORDS

Note use following signal words **DANGER**, **WARNING**, and **CAUTION** with safety messages. Appropriate signal word for each has been selected using following guidelines:

DANGER:

Indicates an imminently hazardous situation that, if not avoided, will result in death or serious injury. This signal word is to be limited to most extreme situations typically for machine components which, for functional purposes, cannot be guarded.

WARNING:

Indicates a potentially hazardous situation that, if not avoided, could result in death or serious injury, and includes hazards that are exposed when guards are removed. It may also be used to alert against unsafe practices.

CAUTION:

Indicates a potentially hazardous situation that, if not avoided, may result in minor or moderate injury. It may also be used to alert against unsafe practices.

If you have questions not answered in this manual, require additional copies, or if your manual is damaged, please contact your dealer or Demco, P.O. Box 189, 4010 320th Street, Boyden, IA 51234
ph: (712) 725-2311 or (712) 725-2302 Toll Free: 1-800-543-3626 Fax: (712) 725-2380
<http://www.demco-products.com>

BOLT TORQUE

TORQUE DATA FOR STANDARD NUTS, BOLTS, AND CAPSCREWS.

Tighten all bolts to torques specified in chart unless otherwise noted. Check tightness of bolts periodically, using bolt chart as guide. Replace hardware with same grade bolt.

NOTE: Unless otherwise specified, high-strength Grade 5 hex bolts are used throughout assembly of equipment.

Bolt Torque for Standard bolts *



Torque Specifications

"A"	GRADE 2		GRADE 5		GRADE 8	
	lb-ft	(N.m)	lb-ft	(N.m)	lb-ft	(N.m)
1/4"	6	(8)	9	(12)	12	(16)
5/16"	10	(13)	18	(25)	25	(35)
3/8"	20	(27)	30	(40)	45	(60)
7/16"	30	(40)	50	(70)	80	(110)
1/2"	45	(60)	75	(100)	115	(155)
9/16"	70	(95)	115	(155)	165	(220)
5/8"	95	(130)	150	(200)	225	(300)
3/4"	165	(225)	290	(390)	400	(540)
7/8"	170	(230)	420	(570)	650	(880)
1"	225	(300)	630	(850)	970	(1310)

Bolt Torque for Metric bolts *

"A"	CLASS 8.8		CLASS 9.8		CLASS 10.9	
	lb-ft	(N.m)	lb-ft	(N.m)	lb-ft	(N.m)
6	9	(13)	10	(14)	13	(17)
7	15	(21)	18	(24)	21	(29)
8	23	(31)	25	(34)	31	(42)
10	45	(61)	50	(68)	61	(83)
12	78	(106)	88	(118)	106	(144)
14	125	(169)	140	(189)	170	(230)
16	194	(263)	216	(293)	263	(357)
18	268	(363)	--	--	364	(493)
20	378	(513)	--	--	515	(689)
22	516	(699)	--	--	702	(952)
24	654	(886)	--	--	890	(1206)

Torque figures indicated are valid for non-greased or non-oiled threads and heads unless otherwise specified. Therefore, do not grease or oil bolts or capscrews unless otherwise specified in this manual. When using locking elements, increase torque values by 5%.

* GRADE or CLASS value for bolts and capscrews are identified by their head markings.

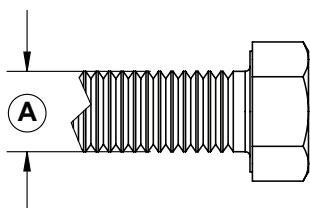

GRADE-2

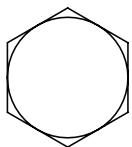

GRADE-5

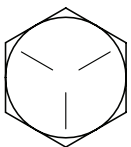

GRADE-8

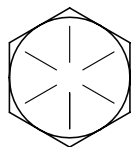

CLASS 8.8

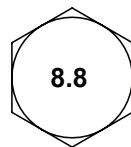

CLASS 9.8

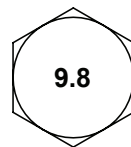

CLASS 10.9

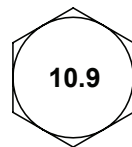

INSTRUCTIONS FOR 13" BRAKES

BRAKE INSTALLATION

1. Brake Mounting Flange

To assure correct brake action, the mounting flange must be square and concentric with the axle spindle. A flange that is not properly installed will contribute to rapid lining wear and improper brake action.

The 13" DEMCO brake is designed to interchange with existing equipment mounting on flanges with (4) holes on 4-13/16" B.C. and a 3-7/8" register diameter. Several manufacturers offer complete axles with flanges attached, or you may choose to install flanges yourself.

Use a flange welding fixture to properly position the flange for welding. Bolt the flange to the welding fixture securely with bolts.

Install the fixture (and flange) onto the spindle and tighten spindle nut. If flange is being installed on a round axle, rotate to secure "wheel cylinder up" location when the axle is installed.

Do not make a continuous weld around the flange. First, tack weld on all four sides between the bolts. Follow this with a full weld up each side of the axle. It is usually not advisable or necessary to weld across the top and bottom of the axle. The bottom of the axle is its most highly stressed area and a weld at this point will weaken the axle. Allow the axle, spindle, and flange to cool before removing welding fixture. See brake drum page for drum face to flange location

2. Installing Brakes

Place the brake against spindle flange. In mounting the brake, be sure the hydraulic wheel cylinder is at the top. Brakes are also marked as "RIGHTS" and "LEFTS". The brake designated as "LEFT" travels on the driver's side of the road.

3. Installing Brake Drum

When the brakes have been correctly assembled to the axle flanges, the hub and drum assemblies may be mounted on the axle spindle.

Pack the inside bearing with suitable wheel bearing grease. Force grease through and around the rollers. Place the bearing in the hub and install the grease seal flush with the end of the hub using an arbor press or soft mallet. Remove excess grease.

To avoid damage to bearing seal, lubricate seal seat prior to putting on the hub. Grease, pack and install the outer bearing on spindle. Place flatwasher and spindle nut on spindle. Tighten spindle nut per hub & bearing manufacturer specifications, then install new cotter pin to lock nut, and install dust cap.

Caution: Do not pack hub full of grease. Excessive grease may leak into brake drums causing brake failure.

Wheels may now be mounted on the hubs.

4. Adjusting Brakes

Before removing the jacks, adjust the brakes.

The brake adjustment nut is located through a slot at the bottom of the backing plate. Insert brake tool or screw driver into slotted hole with handle up and bit against the adjusting wheel, pull down on handle and rotate wheel while tightening. When you can no longer rotate wheel in the forward direction, then loosen the large nut on the back side of the brake cluster, located at the 12 o'clock position, one turn, do not take nut completely off, just loosen to allow anchor pin to realign. Take dead blow hammer and tap on brake drum several times around the perimeter, Now retighten the large anchor pin nut, and back off shoe adjuster 10-15 clicks. If there is one spot where the wheel drags just slightly this is acceptable. As soon as the brake linings are burnished (this requires several braking stops) the brakes will then be set right.

ALWAYS ROTATE DRUM IN DIRECTION OF FORWARD ROTATION ONLY.

! WARNING: To Prevent Serious Injury or Death

Saltwater, granular fertilizers and other corrosive materials are destructive to metal. To prolong the life of a braking system used under corrosive conditions, we recommend that the actuator be flushed periodically with a high pressure water hose. Be sure to re-grease bearings and oil all moving parts after the unit has dried. At the end of the season, when unit is to be stored, remove the brake drums and clean inside the brakes. Pack wheel bearings before drum is installed.

5. Hydraulic Lines

Use care in forming tubing to avoid sharp bends or kinks. Use double flare steel tubing to assure tight leakproof connections. This must be done by a certified brake shop. Anchor all hydraulic lines at two foot intervals to prevent chafing and vibration. Use hydraulic rubber hose at points of flexing. Anchor hose ends to avoid stress on tubing.

6. Bleeding the System

The first requirement for safe, sure hydraulic braking is the use of quality brake fluid. Use only DOT-3 or DOT-4 brake fluid from a sealed container.

Elevate tongue on trailer 4-6 inches

If pressure bleeding equipment is available, follow the manufacturer's instruction in bleeding the system.

If system must be bled manually, proceed as follows: Fill master cylinder with fluid. Install bleeder hose on first wheel cylinder to

be bled (if tandem axle trailer, bleed rear axle first). Have loose end of hose submerged in brake fluid in glass container to observe bubbling.

By loosening the bleeder screw located in the wheel cylinder one turn, the system is open to the atmosphere through the passage drilled in the screw. Pump actuator with short strokes until fluid in master cylinder reservoir stops bubbling, then pump actuator with long steady strokes. The bleeding operation is completed when bubbles no longer rise to the surface of the fluid in glass container. **Be sure to close bleeder screw securely.**

Repeat bleeding operation at each wheel cylinder. During the bleeding process, replenish the brake fluid, so the level does not fall below the 1/2 full level in the master cylinder reservoir. After bleeding is complete, make sure master cylinder reservoir is filled and filler cap is securely in place.

After the bleeding operation has been completed, apply pressure to the system and check the whole brake system for leaks.

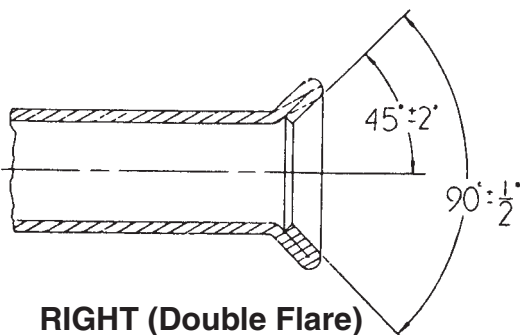
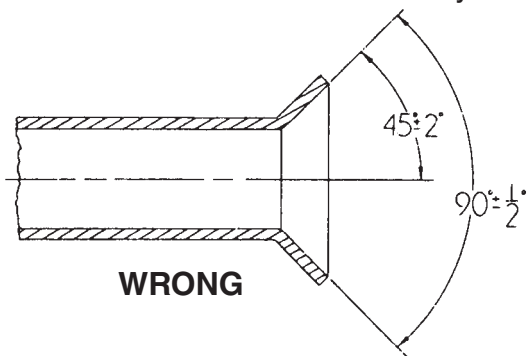

! WARNING: To Prevent Serious Injury or Death

FAILURE TO FOLLOW THESE INSTRUCTIONS, OR FAILURE TO PROPERLY MAINTAIN BRAKES AFTER INSTALLATION, CAN RESULT IN LOSS OF BRAKING ACTION. THIS CAN CAUSE PERSONAL INJURY, DEATH OR PROPERTY DAMAGE. ONLY PROFESSIONAL MECHANICS SHOULD INSTALL BRAKE CLUSTERS. HAVE YOUR BRAKES INSPECTED BY A PROFESSIONAL MECHANIC AT LEAST ANNUALLY AFTER INSTALLATION.

13" BRAKE CLUSTER PARTS BREAKDOWN



13" UNI-SERVO BRAKE CLUSTER PARTS LIST

REF. NO.	PART NO.	QTY.	DESCRIPTION
-	07911	-	Right Hand Cluster
-	07910	-	Left Hand Cluster
1	5509	1	Brake Shoe Kit (2 Front & 2 Rear)
2	SB9776M	1	Wheel Cylinder Assembly - Right
-	SB9777M	1	Wheel Cylinder Assembly - Left

Please order replacement parts by PART NO. and DESCRIPTION.



13" FREE BACKING BRAKE CLUSTER PARTS LIST

REF. NO.	PART NO.	QTY.	DESCRIPTION
-	01971	-	Right Hand Cluster
-	01970	-	Left Hand Cluster
1	5508	1	Brake Shoe Kit (2 Front & 2 Rear)
2	SB9776M	1	Wheel Cylinder Assembly - Right
-	SB9777M	1	Wheel Cylinder Assembly - Left

Please order replacement parts by PART NO. and DESCRIPTION.



13" BRAKE DRUM COMPARISON

Demco Number	Dico Number	Number of Bolts	Bolt Hole Diameter	Bolt Circle	Pilot Hole Diameter	Finished Weight	Drum Style
03532 X	18859	8	17/32"	5-1/2"	4-3/8"	22.53 lbs	B
03940 X	10111	6	17/32"	5-1/2"	4-3/8"	22.58 lbs	B
03941 X	43268	8	17/32"	5-1/2"	4-1/2"	21.88 lbs	B
05353 X	9894	8	5/8"	8"	5-3/4"	20.54 lbs	A
07324 X	16964	6	17/32"	8-1/4"	6"	20.31 lbs	A

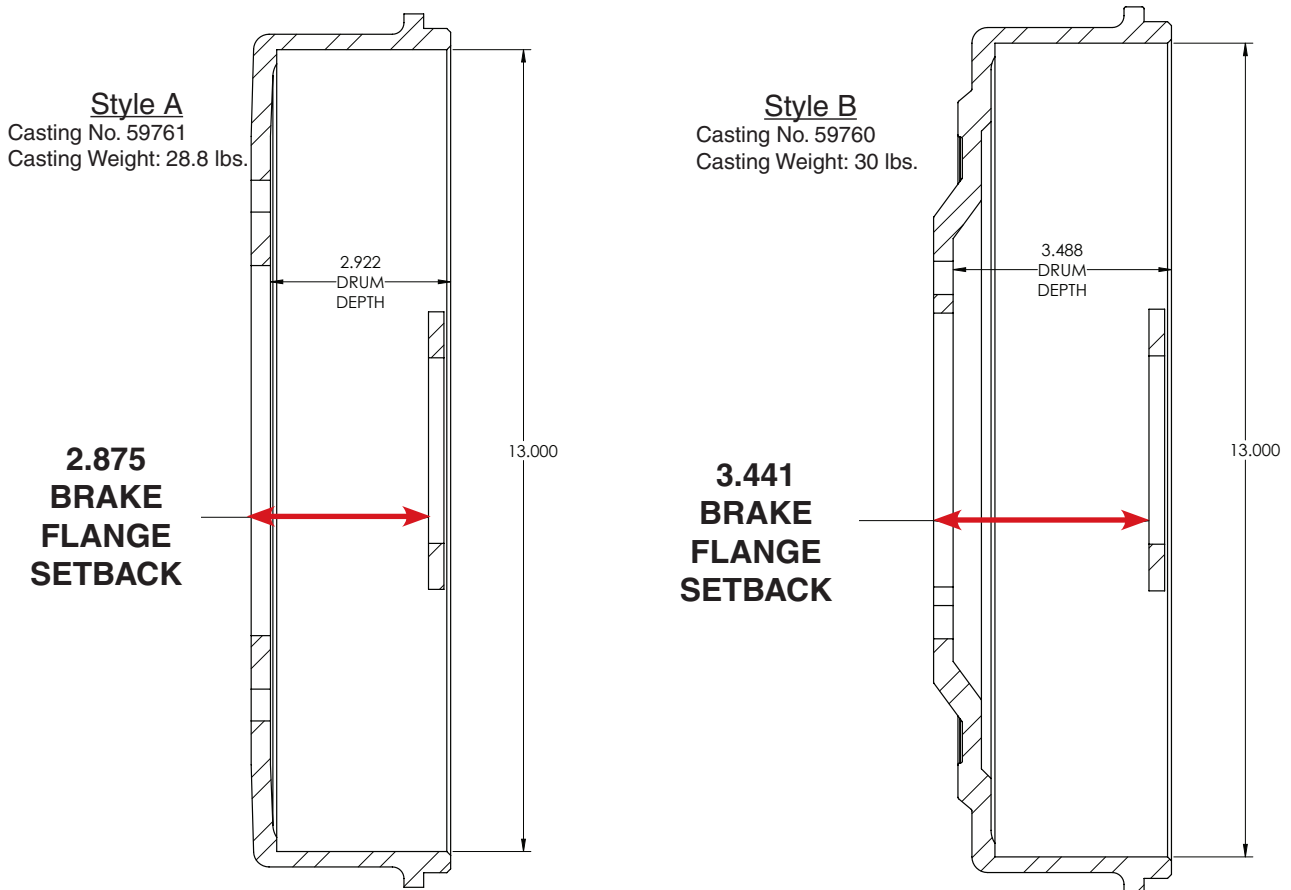

Demco

P.O. BOX 189
 4010 320th St., BOYDEN, IA. 51234
 PH: (712) 725-2311 or (712) 725-2302
 FAX: (712) 725-2380
 TOLL FREE: 1-800-54DEMCO (1-800-543-3626)
www.demco-products.com