



# Demco

## Brakes

### 10" x 2 1/4" Marine



**FREE BACKING**



**UNI-SERVO**

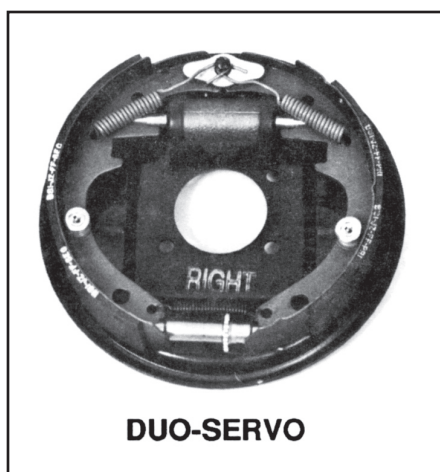

**DUO-SERVO**

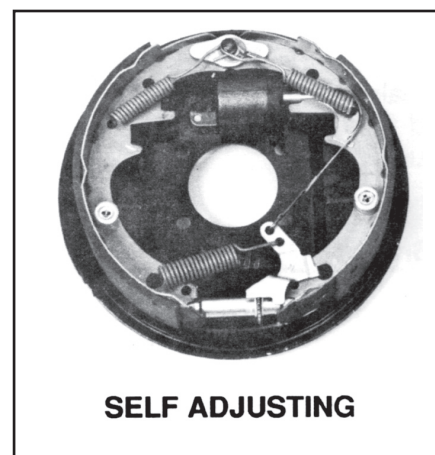

**SELF ADJUSTING**

ASSEMBLY  
CALIBRATION  
OPERATION  
REPLACEMENT PARTS

**READ** *complete manual CAREFULLY  
BEFORE attempting operation.*

Doing Our Best to Provide You the Best

OPERATORS MANUAL



## **WARNING: To Prevent Serious Injury or Death**

FAILURE TO FOLLOW THESE INSTRUCTIONS, OR FAILURE TO PROPERLY MAINTAIN BRAKES AFTER INSTALLATION, CAN RESULT IN LOSS OF BRAKING ACTION. THIS CAN CAUSE PERSONAL INJURY, DEATH OR PROPERTY DAMAGE. ONLY PROFESSIONAL MECHANICS SHOULD INSTALL BRAKE CLUSTERS. HAVE YOUR BRAKES INSPECTED BY A PROFESSIONAL MECHANIC AT LEAST ANNUALLY AFTER INSTALLATION.



## **WARNING: To Prevent Serious Injury or Death**

- Review following instructions before installation and use of hydraulic brakes.
- Dealers or distributors must review these instructions with ultimate user.
- Failure to follow these instructions, or failure to properly maintain braking system after installation, can result in loss of braking action.

### **Table of Contents**

General information.....	2
Safety, Signal Words .....	3
Bolt Torque .....	4
Brake Installation and Maintenance .....	5-6
Marine Free Backing Breakdown & Parts List.....	7
Standard Duo-Servo Breakdown & Parts List .....	8
Marine NDH Self Adjusting Breakdown & Parts List .....	8

## SAFETY

**TAKE NOTE! THIS SAFETY ALERT SYMBOL FOUND THROUGHOUT THIS MANUAL IS USED TO CALL YOUR ATTENTION TO INSTRUCTIONS INVOLVING YOUR PERSONAL SAFETY AND SAFETY OF OTHERS. FAILURE TO FOLLOW THESE INSTRUCTIONS CAN RESULT IN INJURY OR DEATH.**



**THIS SYMBOL MEANS**

**ATTENTION**

**BECOME ALERT**

**YOUR SAFETY IS INVOLVED!**

### **SIGNAL WORDS**

Note use following signal words **DANGER**, **WARNING**, and **CAUTION** with safety messages. Appropriate signal word for each has been selected using following guidelines:

#### **DANGER:**

Indicates an imminently hazardous situation that, if not avoided, will result in death or serious injury. This signal word is to be limited to most extreme situations typically for machine components which, for functional purposes, cannot be guarded.

#### **WARNING:**

Indicates a potentially hazardous situation that, if not avoided, could result in death or serious injury, and includes hazards that are exposed when guards are removed. It may also be used to alert against unsafe practices.

#### **CAUTION:**

Indicates a potentially hazardous situation that, if not avoided, may result in minor or moderate injury. It may also be used to alert against unsafe practices.

If you have questions not answered in this manual, require additional copies, or if your manual is damaged, please contact your dealer or Demco, P.O. Box 189, 4010 320th Street, Boyden, IA 51234  
ph: (712) 725-2311 or (712) 725-2302 Toll Free: 1-800-543-3626 Fax: (712) 725-2380  
<http://www.demco-products.com>

# BOLT TORQUE

## TORQUE DATA FOR STANDARD NUTS, BOLTS, AND CAPSCREWS.

Tighten all bolts to torques specified in chart unless otherwise noted. Check tightness of bolts periodically, using bolt chart as guide. Replace hardware with same grade bolt.

NOTE: Unless otherwise specified, high-strength Grade 5 hex bolts are used throughout assembly of equipment.

### Bolt Torque for Standard bolts \*



### Torque Specifications

"A"	GRADE 2		GRADE 5		GRADE 8	
	lb-ft	(N.m)	lb-ft	(N.m)	lb-ft	(N.m)
1/4"	6	(8)	9	(12)	12	(16)
5/16"	10	(13)	18	(25)	25	(35)
3/8"	20	(27)	30	(40)	45	(60)
7/16"	30	(40)	50	(70)	80	(110)
1/2"	45	(60)	75	(100)	115	(155)
9/16"	70	(95)	115	(155)	165	(220)
5/8"	95	(130)	150	(200)	225	(300)
3/4"	165	(225)	290	(390)	400	(540)
7/8"	170	(230)	420	(570)	650	(880)
1"	225	(300)	630	(850)	970	(1310)

### Bolt Torque for Metric bolts \*

"A"	CLASS 8.8		CLASS 9.8		CLASS 10.9	
	lb-ft	(N.m)	lb-ft	(N.m)	lb-ft	(N.m)
6	9	(13)	10	(14)	13	(17)
7	15	(21)	18	(24)	21	(29)
8	23	(31)	25	(34)	31	(42)
10	45	(61)	50	(68)	61	(83)
12	78	(106)	88	(118)	106	(144)
14	125	(169)	140	(189)	170	(230)
16	194	(263)	216	(293)	263	(357)
18	268	(363)	--	--	364	(493)
20	378	(513)	--	--	515	(689)
22	516	(699)	--	--	702	(952)
24	654	(886)	--	--	890	(1206)

Torque figures indicated are valid for non-greased or non-oiled threads and heads unless otherwise specified. Therefore, do not grease or oil bolts or capscrews unless otherwise specified in this manual. When using locking elements, increase torque values by 5%.

\* GRADE or CLASS value for bolts and capscrews are identified by their head markings.

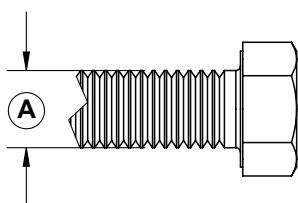

GRADE-2

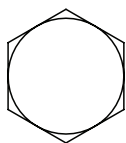

GRADE-5

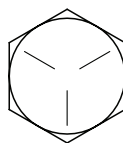

GRADE-8

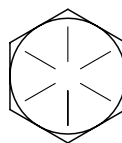

CLASS 8.8

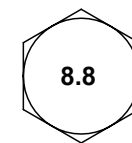

CLASS 9.8

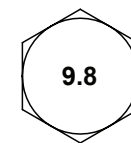

CLASS 10.9

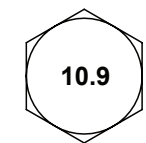

# INSTRUCTIONS FOR 10" BRAKES

## BRAKE INSTALLATION

**ALWAYS ROTATE DRUM IN DIRECTION OF FORWARD ROTATION ONLY.**

### 1. Brake Mounting Flange

To assure correct brake action, the mounting flange must be square and concentric with the axle spindle. A flange that is not properly installed will contribute to rapid lining wear and improper brake action.

The 10" DEMCO brake is designed to interchange with existing equipment mounting on flanges with (4) holes on 4" B.C. and a 3" register diameter. Several manufacturers offer complete axles with flanges attached, or you may choose to install flanges yourself.

Two types of cluster plates are used. One with 4" B.C. square pattern for conventional hubs and one with 4" B.C. rectangular pattern for new departure hubs.

Use a flange welding fixture to properly position the flange for welding. Bolt the flange to the welding fixture securely with bolts.

Install the fixture (and flange) onto the spindle and tighten spindle nut. If flange is being installed on a round axle, rotate to insure "wheel cylinder up" location when the axle is installed.

Do not make a continuous weld around the flange. First, tack weld on all four sides between the bolts. Follow this with a full weld up each side of the axle. It is usually not advisable or necessary to weld across the top and bottom of the axle. The bottom of the axle is its most highly stressed area and a weld at this point will weaken the axle. Allow the axle, spindle, and flange to cool before removing welding fixture. Brake flange set back is 1-1/4" minimum from inside bearing stop to flange.

### 2. Installing Brakes

Place the brake against spindle flange. In mounting the brake, be sure the hydraulic wheel cylinder is at the top. Brakes are also marked as "RIGHTS" and "LEFTS". The brake designated as "LEFT" travels on the driver's side of the road.

### 3. Installing Brake Drum

When the brakes have been correctly assembled to the axle flanges, the hub and drum assemblies may be mounted on the axle spindle.

Two types of hubs may be used. The new departure hub is greased for life and does not need packing. The conventional hub however is packed as follows.

Pack the inside bearing with suitable wheel bearing grease. Force grease through and around the rollers. Place the bearing in the hub and install the grease seal flush with the end of the hub using an arbor press or soft mallet. Remove excess grease.

To avoid damage to bearing seal, lubricate seal seat prior to putting on the hub. Grease, pack and install the outer bearing on spindle. Place flat washer and spindle nut on spindle. Tighten spindle nut per hub & bearing manufacturing specifications, then install new cotter pin to lock nut and install dust cap.

**Caution:** Do not pack hub full of grease. Excessive grease may leak into brake drums causing brake failure.

Wheels may now be mounted on the trailers.

### 4. Adjusting Brakes

**Non Self adjusting brakes** must be adjusted up tight and then back off 15-20 clicks. If there is one spot where the wheel drags just slightly this is acceptable.

**Self adjusting brakes** must be adjusted the first time only to assure having brakes the first few times they are applied. Insert a brake adjusting tool or screw driver into the slotted hole. With the handle up and the bit down and against the adjusting nut, pull down on the handle. While spinning the wheel adjust the cog wheel up until you start to get a little brake drag on the wheel. **Do not over tighten the adjusting nut.** You can not back the nut off unless you hold the adjusting shoe away from the nut while turning it back.

**! WARNING: To Prevent Serious Injury or Death**

Saltwater, granular fertilizers and other corrosive materials are destructive to metal. To prolong the life of a braking system used under corrosive conditions, we recommend that the actuator be flushed periodically with a high pressure water hose. Be sure to re-grease bearings and oil all moving parts after the unit has dried. At the end of the season, when unit is to be stored, remove the brake drums and clean inside the brakes. Pack wheel bearings before drum is installed.

**5. Hydraulic Lines**

Use care in forming tubing to avoid sharp bends or kinks. Use double flare steel tubing to assure tight leak-proof connections. Anchor all hydraulic lines at two foot intervals to prevent chafing and vibration. Use hydraulic rubber hose at points of flexing. Anchor hose ends to avoid stress on tubing.

**6. Bleeding the System**

The first requirement for safe, sure hydraulic braking is the use of quality brake fluid. Use only DOT-3 or DOT-4 brake fluid from a sealed container.

**Elevate tongue on trailer 4-6 inches**

If pressure bleeding equipment is available, follow the manufacturer's instruction in bleeding the system.

**If system must be bled manually, proceed as follows:** Fill master cylinder with fluid. Install bleeder hose on first wheel cylinder to be bled (if tandem axle trailer,

bleed rear axle first). Have loose end of hose submerged in brake fluid in glass container to observe bubbling.

By loosening the bleeder screw located in the wheel cylinder one turn, the system is open to the atmosphere through the passage drilled in the screw. Pump actuator with short strokes until fluid in master cylinder reservoir stops bubbling, then pump actuator with long steady strokes. The bleeding operation is completed when bubbles no longer rise to the surface of the fluid in glass container. **Be sure to close bleeder screw securely.**

Repeat bleeding operation at each wheel cylinder. During the bleeding process, replenish the brake fluid, so the level does not fall below the 1/2 full level in the master cylinder reservoir. After bleeding is complete, fill the master cylinder reservoir and secure the filler cap.

After the bleeding operation has been completed, apply pressure to the system and check the brake system for leaks.

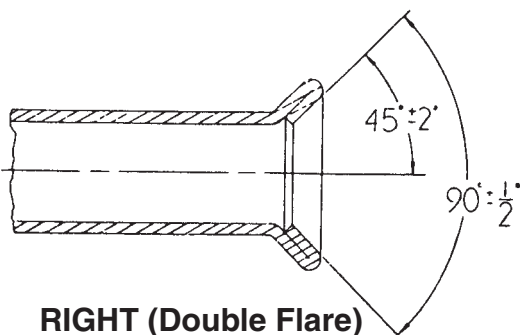
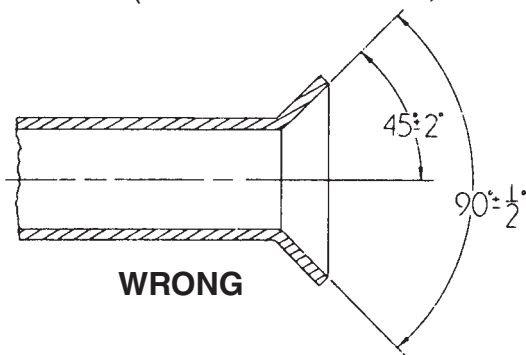

**! WARNING: To Prevent Serious Injury or Death**

FAILURE TO FOLLOW THESE INSTRUCTIONS, OR FAILURE TO PROPERLY MAINTAIN BRAKES AFTER INSTALLATION, CAN RESULT IN LOSS OF BRAKING ACTION. THIS CAN CAUSE PERSONAL INJURY, DEATH OR PROPERTY DAMAGE. ONLY PROFESSIONAL MECHANICS SHOULD INSTALL BRAKE CLUSTERS. HAVE YOUR BRAKES INSPECTED BY A PROFESSIONAL MECHANIC AT LEAST ANNUALLY AFTER INSTALLATION.

## 10" MARINE FREE BACKING BRAKES

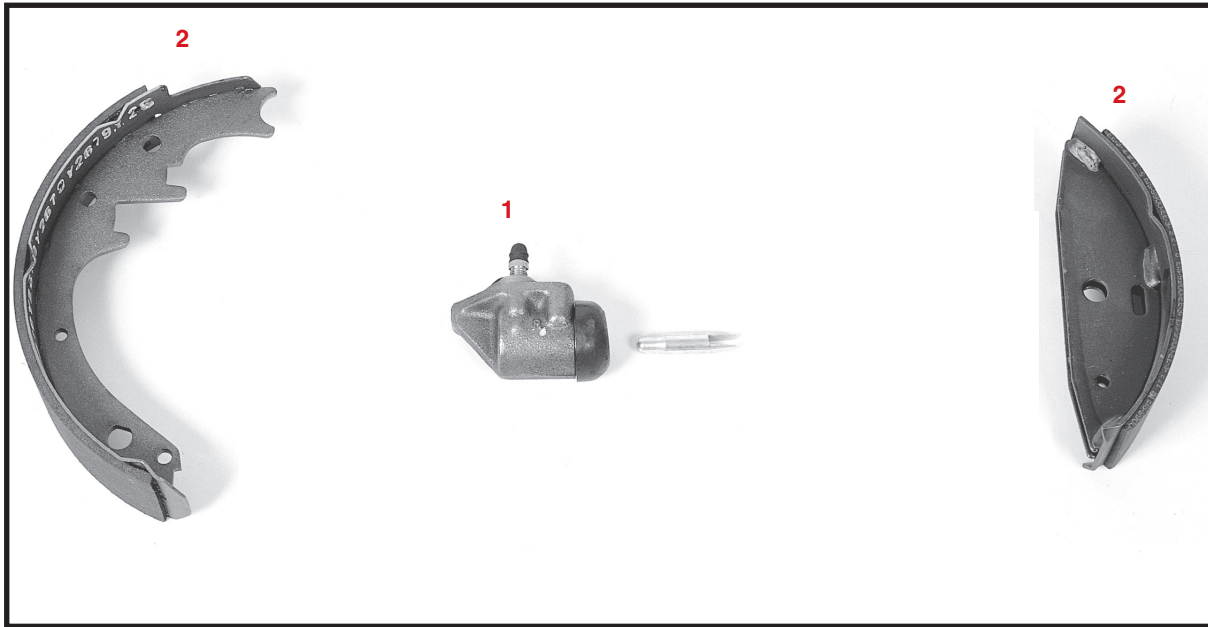

### PARTS LIST for 10" FREE BACKING BRAKES

REF. NO.	PART NO.	QTY.	DESCRIPTION
-	SB40715M	-	Right Hand Cluster-Conv. MARINE
-	SB40716M	-	Left Hand Cluster-Conv. MARINE
1.	SB9776M	1	Wheel Cylinder Assembly-Right MARINE
-	SB9777M	1	Wheel Cylinder Assembly-Left MARINE
2.	07812	1	Brake Shoe Kit (2 front & 2 rear) MARINE

## 10" MARINE UNI-SERVO BRAKES

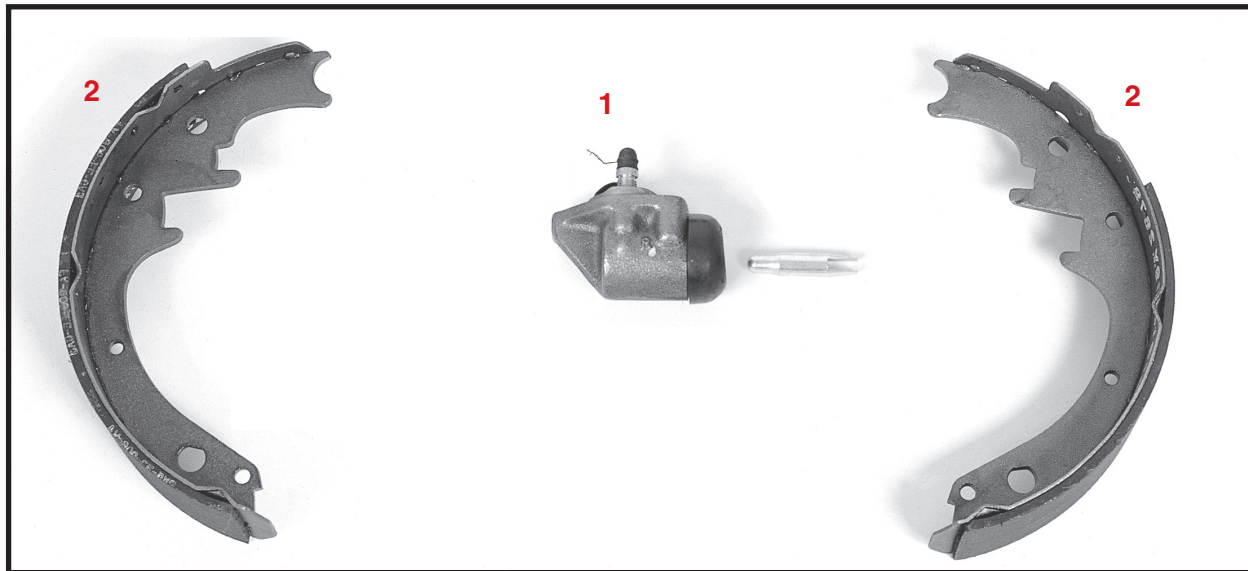

### PARTS LIST for 10"UNI-SERVO BRAKES

REF. NO.	PART NO.	QTY.	DESCRIPTION
-	SB18787M	-	Right Hand Cluster-Conv. MARINE
-	SB18788M	-	Left Hand Cluster-Conv. MARINE
1.	SB9776M	1	Wheel Cylinder Assembly-Right MARINE
-	SB9777M	1	Wheel Cylinder Assembly-Left MARINE
2.	07811	1	Brake Shoe Kit (2 front & 2 rear) MARINE

Please order replacement parts by **PART NO.** and **DESCRIPTION.**

## 10" STANDARD DUO-SERVO BRAKES

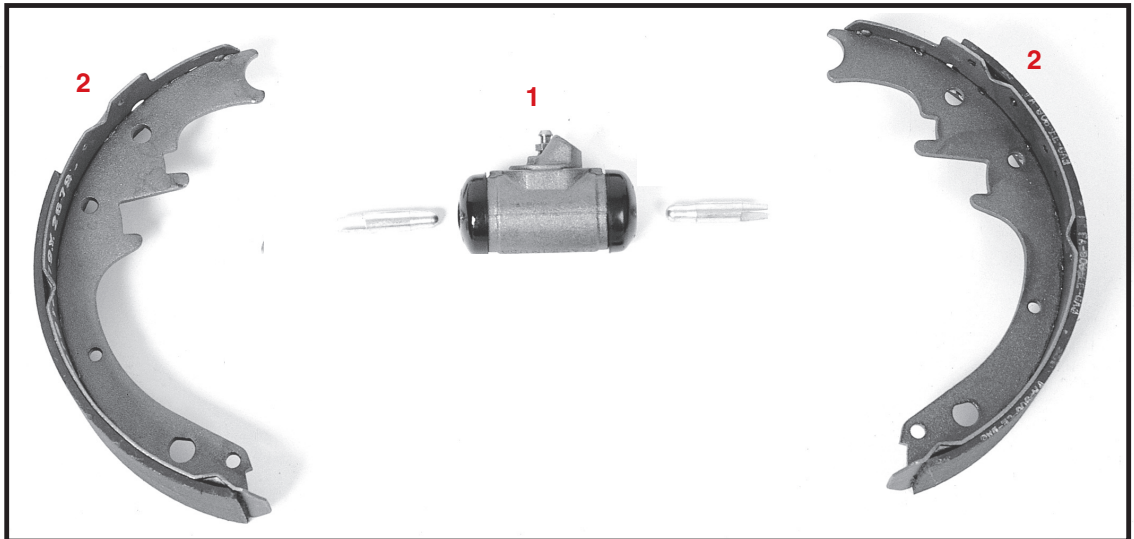

### PARTS LIST for 10"DUO-SERVO BRAKES

REF. NO.	PART NO.	QTY.	DESCRIPTION
-	SB18793	-	Right Hand Cluster-Conv.
-	SB18794	-	Left Hand Cluster-Conv. (shown)
1.	SB17186	1	Wheel Cylinder Assembly-Right
-	SB17186	1	Wheel Cylinder Assembly-Left
2.	07811	1	Brake Shoe Kit (2 front & 2 rear)

Please order replacement parts by  
**PART NO. and DESCRIPTION.**

## 10" MARINE NDH SELF ADJUSTING BRAKES

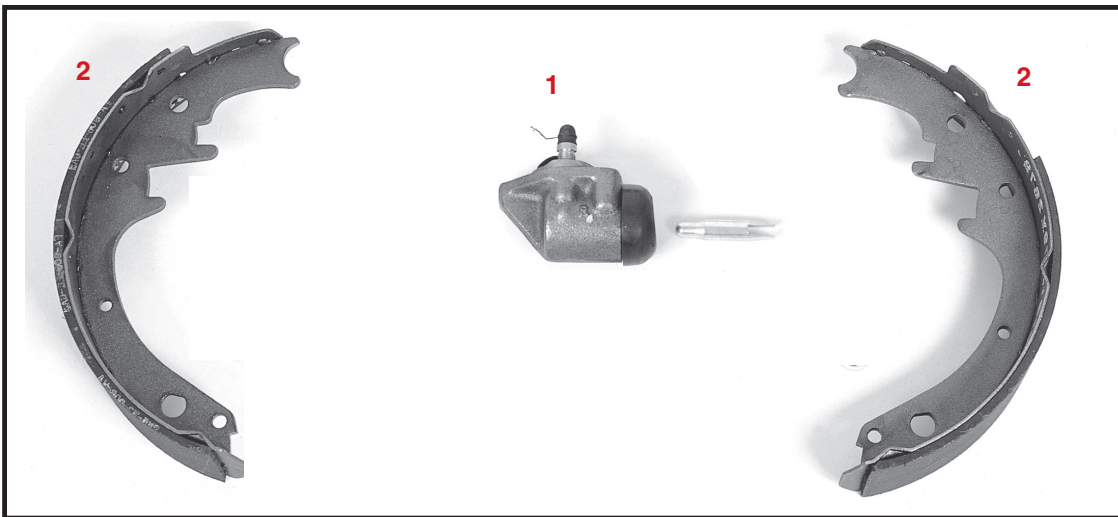

### PARTS LIST for 10"SELF ADJUSTING BRAKES

REF. NO.	PART NO.	QTY.	DESCRIPTION
-	SB24428M	-	Right Hand Cluster - NDH
-	SB24429M	-	Left Hand Cluster - NDH
1.	SB9776M	1	Wheel Cylinder Assembly - Right
-	SB9777M	1	Wheel Cylinder Assembly - Left
2.	07811	1	Brake Shoe Kit (2 front & 2 rear)

P.O. BOX 189

4010 320th St., BOYDEN, IA. 51234

PH: (712) 725-2311 or (712) 725-2302

FAX: (712) 725-2380

TOLL FREE: 1-800-54DEMCO (1-800-543-3626)

www.demco-products.com