

WIRING & FUNCTIONS (A3)

Different applications require different functions. It is highly recommended to determine and configure the required functions prior to Installation; (refer to 'CONTROL WIRES' section).

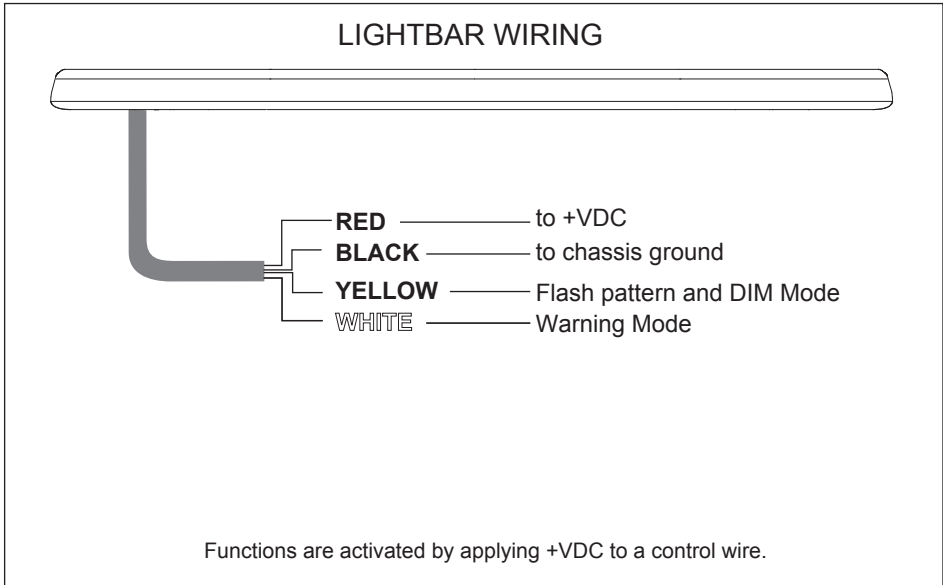

NOTE: Middle Section lights are independently switched and do not form part of the R65 Approval.

POWER WIRES

1. Route Power Cable to the vehicle firewall towards the battery.
2. Follow factory wiring harness through the firewall. It may be necessary to drill a hole in the firewall. Ensure that there are no components that could be damaged from the drilling.
3. Route the cable to the battery.
4. Install a 15Amp fuse (user-supplied) on the end of **RED** wire, then connect to battery.
5. Connect **BLACK** wire to the factory chassis ground adjacent to the battery.

NOTE: make sure that all wires of power cable are securely connected to power source.

CONTROL WIRES

1. Route Control wires towards the dash area to a switch panel (user-supplied).
2. Connect the required wires to the switch panel.

WARNING MODE

Activate Warning Mode by applying **+VDC** to **WHITE** wire. There is a list of built-in flash patterns to choose from. While in Warning Mode, tap **+VDC** to **YELLOW** wire:

- Once for next pattern.
- Quickly 3 times for FP#0.

FP#	FLASH PATTERN		
0	Kit Scan (split)	13	Single H/L (split)
1	Outside-In Single	14	Single (all)
2	Outside-In Ultra	15	Double (all)
3	Side-by-Side Single	16	Quad (all)
4	Side-by-Side Ultra	17	Quint (all)
5	Random	18	Mega (all)
6	Single (split)	19	Ultra (all)
7	Double (split)	20	Single-Quad (all)
8	Quad (split)	21	Single H/L (all)
9	Quint (split)	22	Single Cross
10	Mega (split)	23	Ultra Cross
11	Ultra (split)	24	Rotator1
12	Single-Quad (split)	25	Rotator2

DIM MODE

The Lightbar can be activated in DIM Mode by applying **+12VDC** to **YELLOW** wire.