

Premium Supply

Power Hoist Capacity Chart

IMPORTANT: Because of variations in application, the data contained in these tables is provided as a general guide only.

Capacities are based on the following:

1. Water level non-diminishing load.
2. The vertical height between the rear hinge pivot and the floor is no less than 3 inches.
3. The hydraulic relief pressure is set at 3,200 psi.

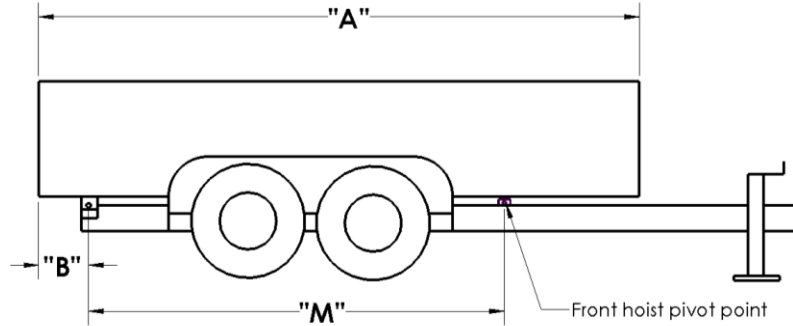

PH310 Hoist Capacity (Tons)						
"A" Body (Feet)	"B" Overhang (Inches)	Dump Angle (Degrees) "M" Dimension (Inches)				
		30° 80.0"	35° 70.0"	40° 61.0"	45° 55.0"	50° 50.0"
8	12	5.2	4.7	4.1	3.8	3.4
8	18	6.5	5.7	5.0	4.5	4.0
8	24	8.2	7.2	6.2	5.6	5.0
9	12	4.5	4.0	3.5	3.1	2.9
9	18	5.3	4.7	4.1	3.8	3.4
9	24	6.5	5.7	5.0	4.5	4.1
10	12	4.0	3.5	3.0	2.9	2.4
10	18	4.6	4.0	3.4	3.2	2.9
10	24	5.3	4.7	4.1	3.8	3.4

PH416 Hoist Capacity (Tons)						
"A" Body (Feet)	"B" Overhang (Inches)	Dump Angle (Degrees) "M" Dimension (Inches)				
		30° 116.0"	35° 101.0"	40° 87.0"	45° 79.0"	50° 71.5"
10	12	12.5	10.9	9.3	8.7	7.8
10	18	14.3	12.4	10.7	9.9	9.0
10	24	16.7	14.6	12.5	11.4	10.3
12	12	10.0	8.6	7.4	6.9	6.3
12	18	11.1	9.6	8.3	7.7	7.0
12	24	12.5	10.9	9.3	8.7	7.8
14	12	8.2	7.2	6.1	5.6	5.0
14	18	9.0	7.9	6.7	6.1	5.5
14	24	10.0	8.6	7.4	6.7	6.1

Premium Supply

Power Hoist Capacity Chart

PH516 Hoist Capacity (Tons)						
"A" Body (Feet)	"B" Overhang (Inches)	Dump Angle (Degrees) "M" Dimension (Inches)				
		30° 113.0"	35° 97.0"	40° 85.0"	45° 76.0"	50° 67.5"
10	12	14.2	12.1	10.6	9.6	6.7
10	18	16.2	13.9	12.2	11.0	9.9
10	24	19.0	16.3	14.2	12.8	11.6
12	12	11.3	9.7	8.5	7.6	6.9
12	18	12.6	10.9	9.4	8.5	7.7
12	24	14.2	12.1	10.6	9.6	8.7
14	12	9.4	8.0	7.0	6.4	5.8
14	18	10.2	8.9	7.7	6.9	6.3
14	24	11.3	9.7	8.5	7.6	6.9

PH520 Hoist Capacity (Tons)						
"A" Body (Feet)	"B" Overhang (Inches)	Dump Angle (Degrees) "M" Dimension (Inches)				
		30° 142.0"	35° 125.0"	40° 109.0"	45° 96.75"	50° 87.75"
12	12	14.3	12.5	11.0	9.9	9.0
12	18	15.9	13.7	12.1	11.2	10.1
12	24	17.9	15.7	13.7	12.5	11.3
14	12	11.9	10.4	9.0	8.3	7.5
14	18	12.9	11.4	9.9	9.0	8.1
14	24	14.5	12.5	10.9	9.7	8.7
16	12	10.1	8.9	7.7	7.1	6.4
16	18	10.9	9.6	8.3	7.7	6.9
16	24	11.9	10.4	9.0	8.0	7.3

PH620 Hoist Capacity (Tons)						
"A" Body (Feet)	"B" Overhang (Inches)	Dump Angle (Degrees) "M" Dimension (Inches)				
		30° 130.0"	35° 113.25"	40° 100.0"	45° 90.25"	50° 81.75"
14	12	15.8	13.7	12.1	11.0	10.0
14	18	17.2	15.0	13.2	12.0	10.9
14	24	19.0	16.5	14.5	13.3	12.0
16	12	13.5	11.7	10.3	9.5	8.6
16	18	14.5	12.6	11.1	10.2	9.2
16	24	15.8	13.7	12.1	11.0	10.0
18	12	11.8	10.2	9.0	8.1	7.3
18	18	12.5	11.0	9.6	8.8	8.0
18	24	13.5	10.2	10.3	9.5	8.6

Premium Supply

Power Hoist Capacity Chart

PH625 Hoist Capacity (Tons)						
"A" Body (Feet)	"B" Overhang (Inches)	Dump Angle (Degrees) "M" Dimension (Inches)				
		30° 150.0"	35° 131.0"	40° 115.0"	45° 104.0"	50° 95.0"
16	12	16.8	14.6	12.8	11.8	10.7
16	18	18.1	15.8	13.8	12.7	11.6
16	24	19.6	17.1	15.0	13.7	12.5
18	12	14.7	12.8	11.2	10.1	9.2
18	18	15.7	13.6	12.0	11.0	10.7
18	24	16.8	14.6	12.8	11.8	11.9
20	12	13.0	11.3	10.0	9.0	8.2
20	18	13.8	12.0	10.5	9.7	8.8
20	24	14.7	12.8	11.2	10.3	9.4

PH630 Hoist Capacity (Tons)						
"A" Body (Feet)	"B" Overhang (Inches)	Dump Angle (Degrees) "M" Dimension (Inches)				
		30° 195.0"	35° 170.0"	40° 150.0"	45° 135.0"	50° 123.0"
18	12	17.3	15.0	13.2	12.0	10.9
18	18	18.4	16.1	14.1	12.9	11.8
18	24	19.8	17.2	15.2	13.8	12.6
20	12	15.3	13.3	11.8	10.6	9.6
20	18	16.2	14.1	12.5	11.2	10.2
20	24	17.3	15.1	13.3	12.0	10.9
22	12	13.8	12.0	10.6	9.5	8.6
22	18	14.5	12.6	11.1	10.0	9.1
22	24	15.3	13.3	11.7	10.6	9.6
24	12	12.5	10.9	9.6	8.6	7.8
24	18	13.1	11.4	10.1	9.1	8.2
24	24	13.8	12.0	10.5	9.5	8.6