

310
MODEL

POWER HOISTS

A=24
B=27
C=20
D=4
E=29
F=14.25
G=6

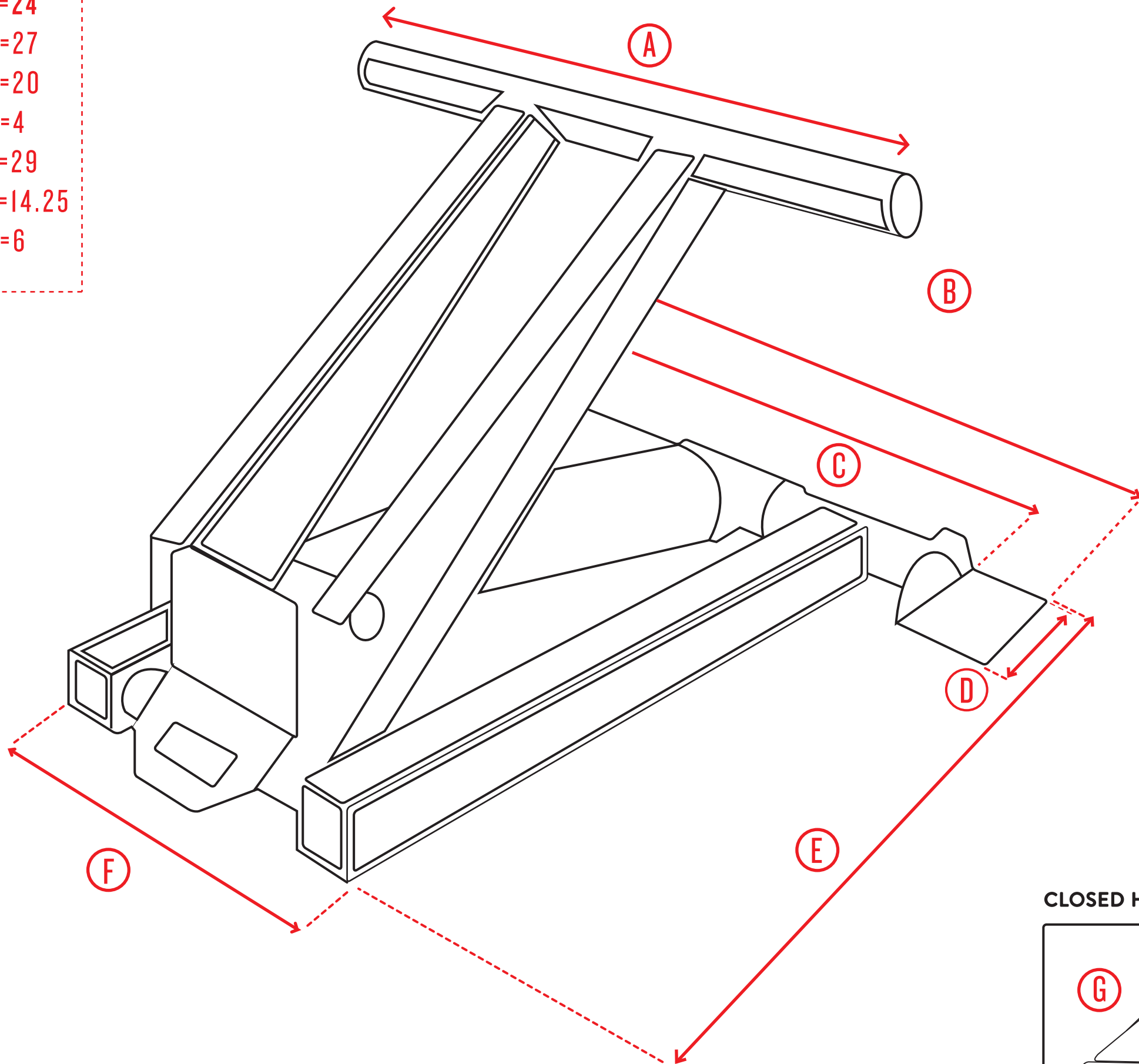

CLOSED HOIST

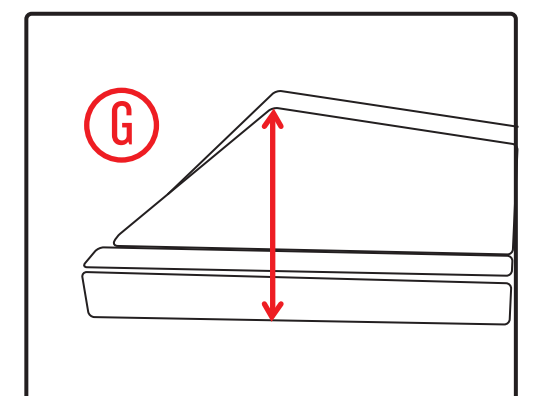

416
MODEL

POWER HOISTS

A=24
B=29
C=20
D=5
E=40
F=16
G=9

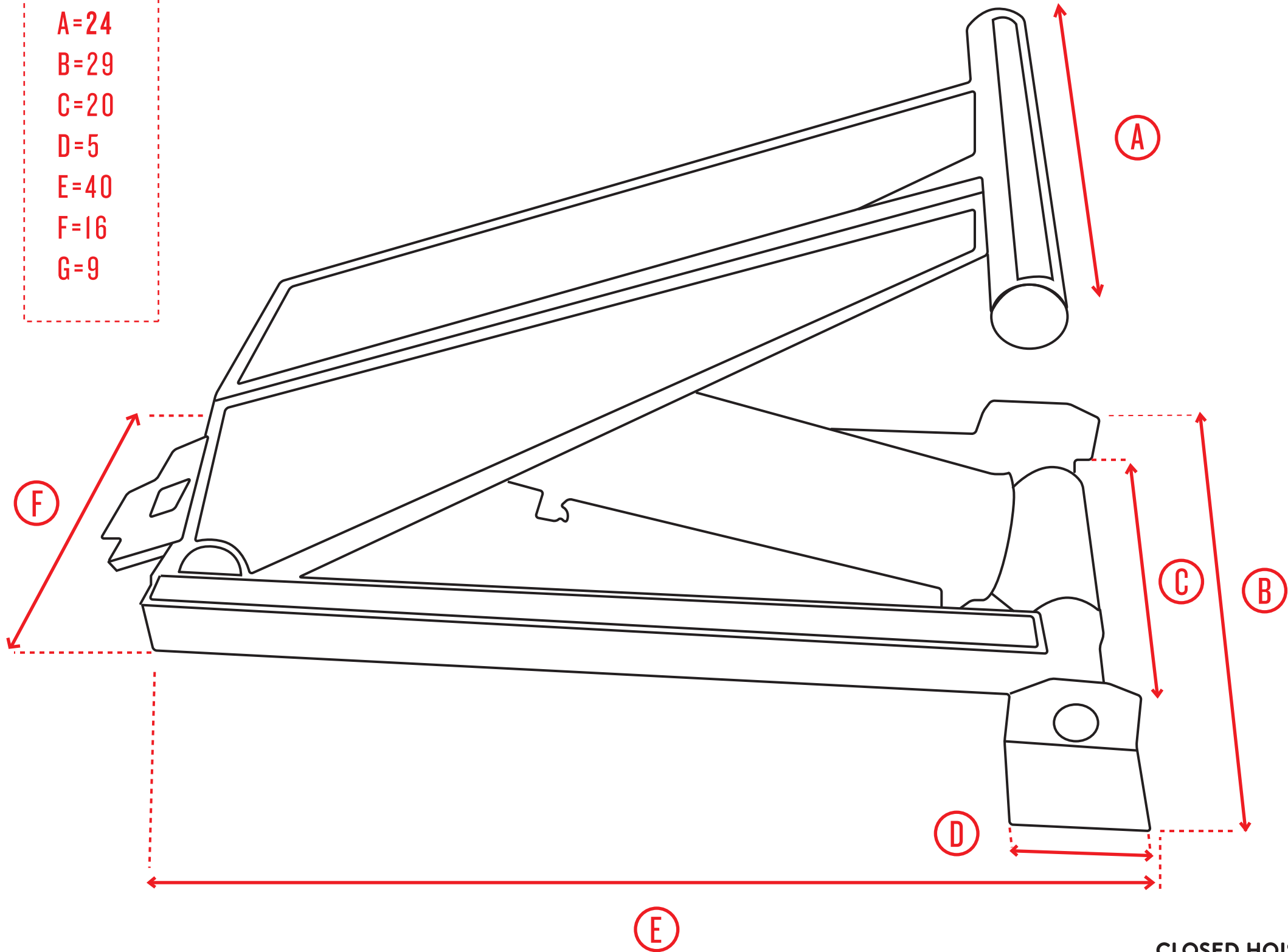

CLOSED HOIST

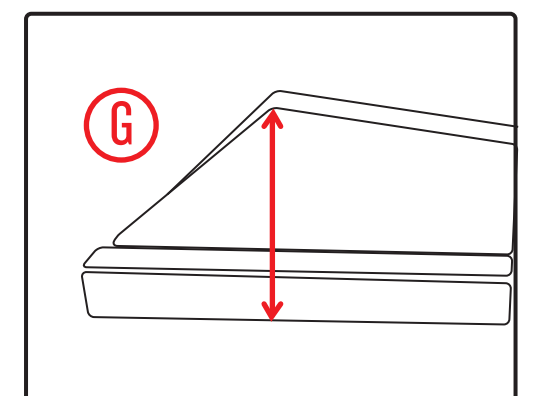

516
MODEL

POWER HOISTS

A=24
B=29
C=20
D=5
E=40
F=16
G=10.5

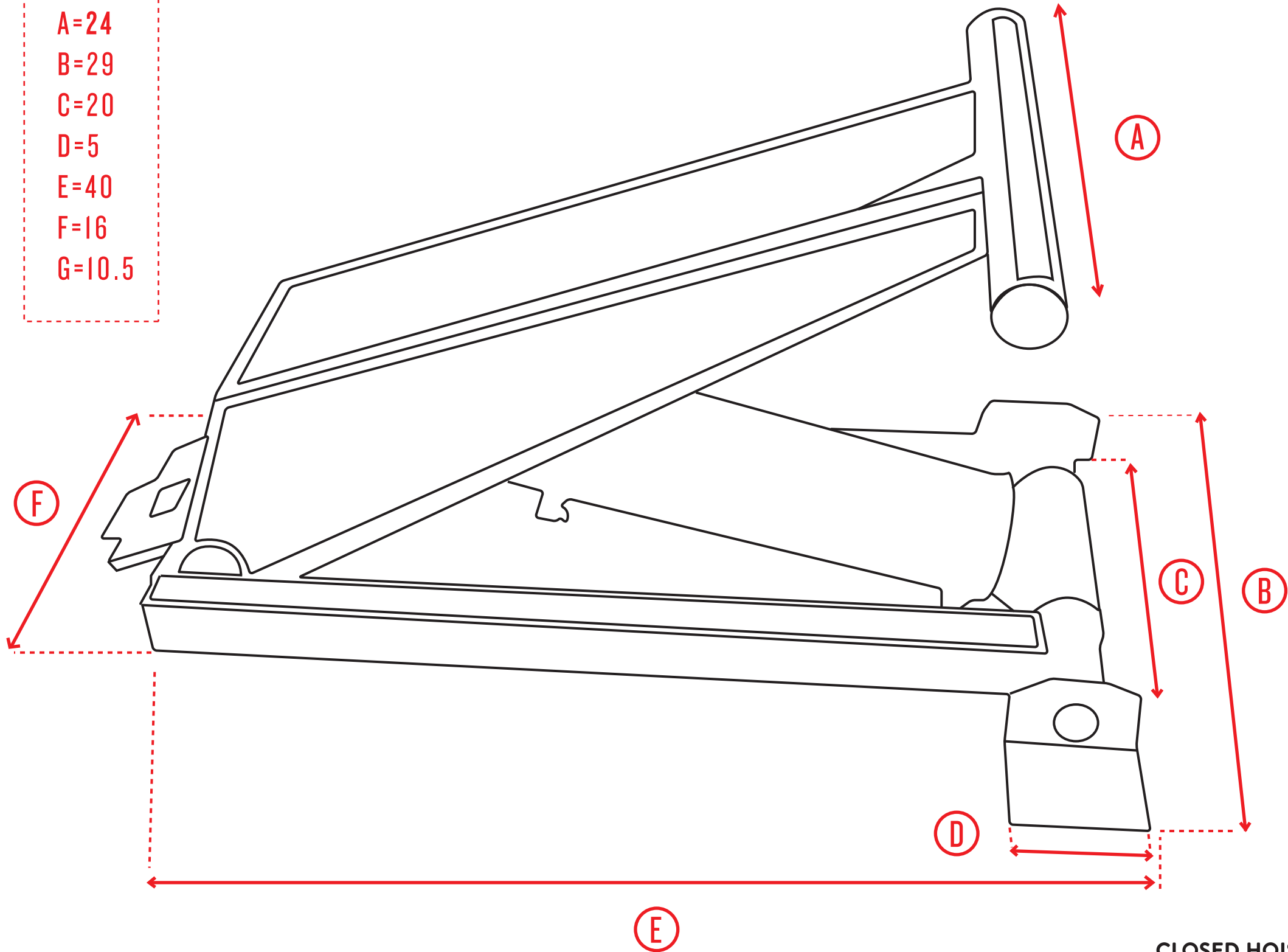

CLOSED HOIST

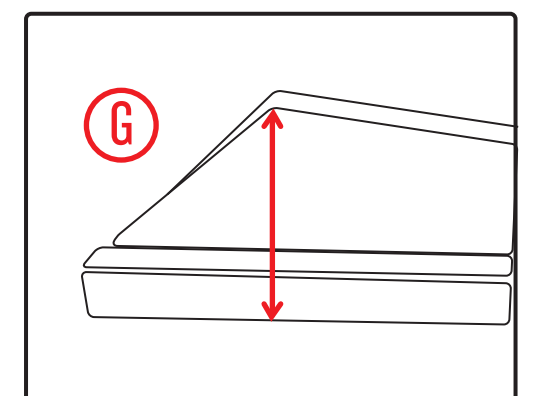

520
MODEL

POWER HOISTS

A=24
B=29
C=20
D=5
E=48
F=16
G=11

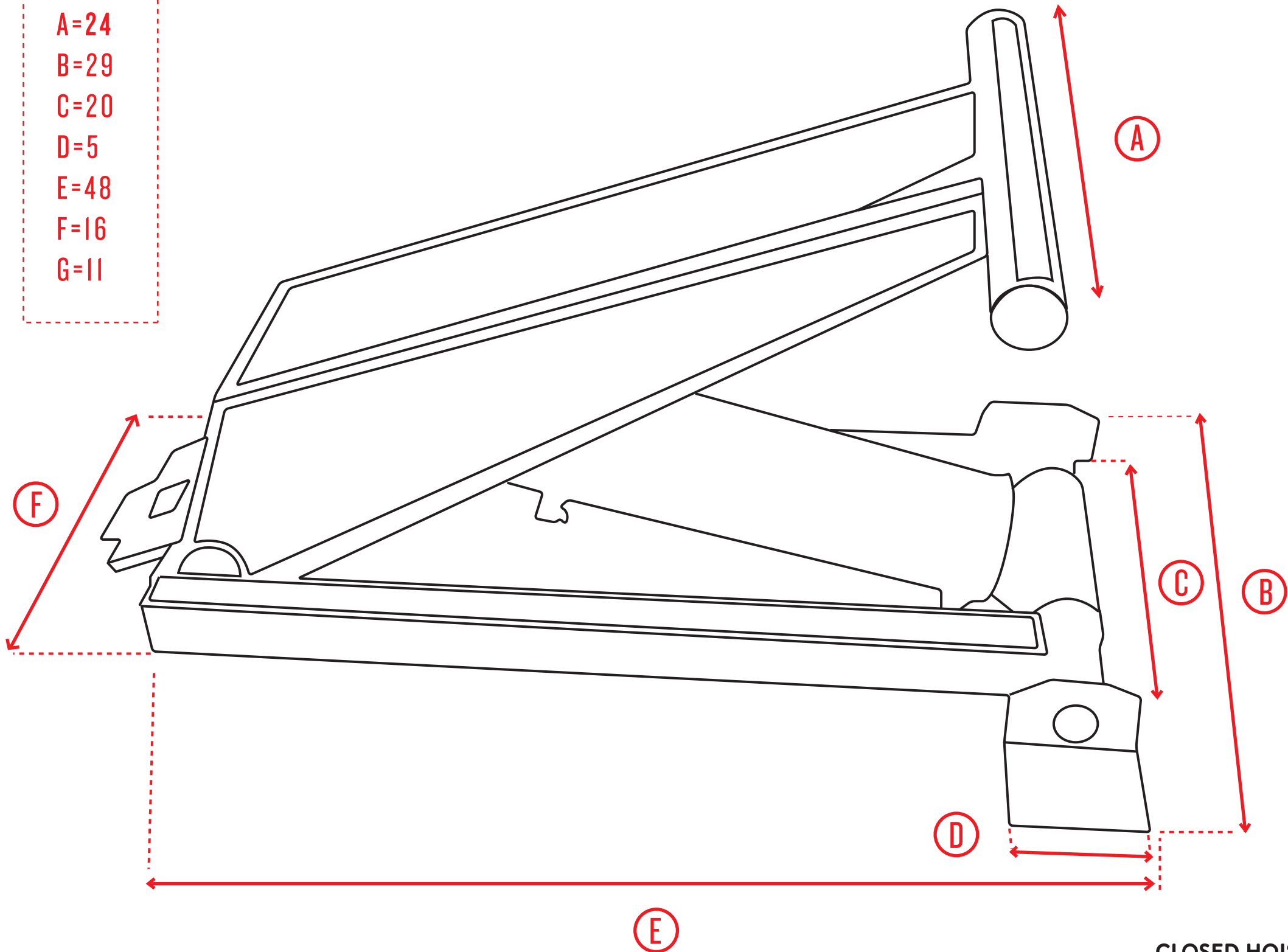

CLOSED HOIST

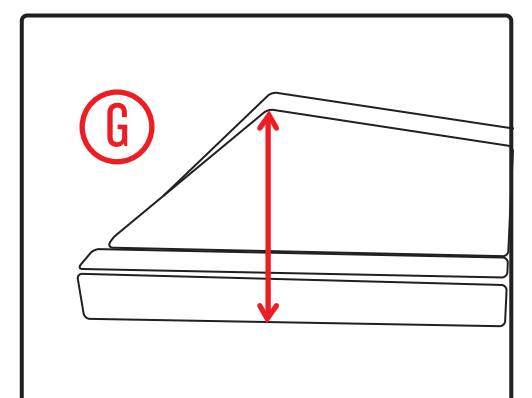

620
MODEL

POWER HOISTS

A=24
B=38
C=25.25
D=10
E=51.25
F=23
G=13

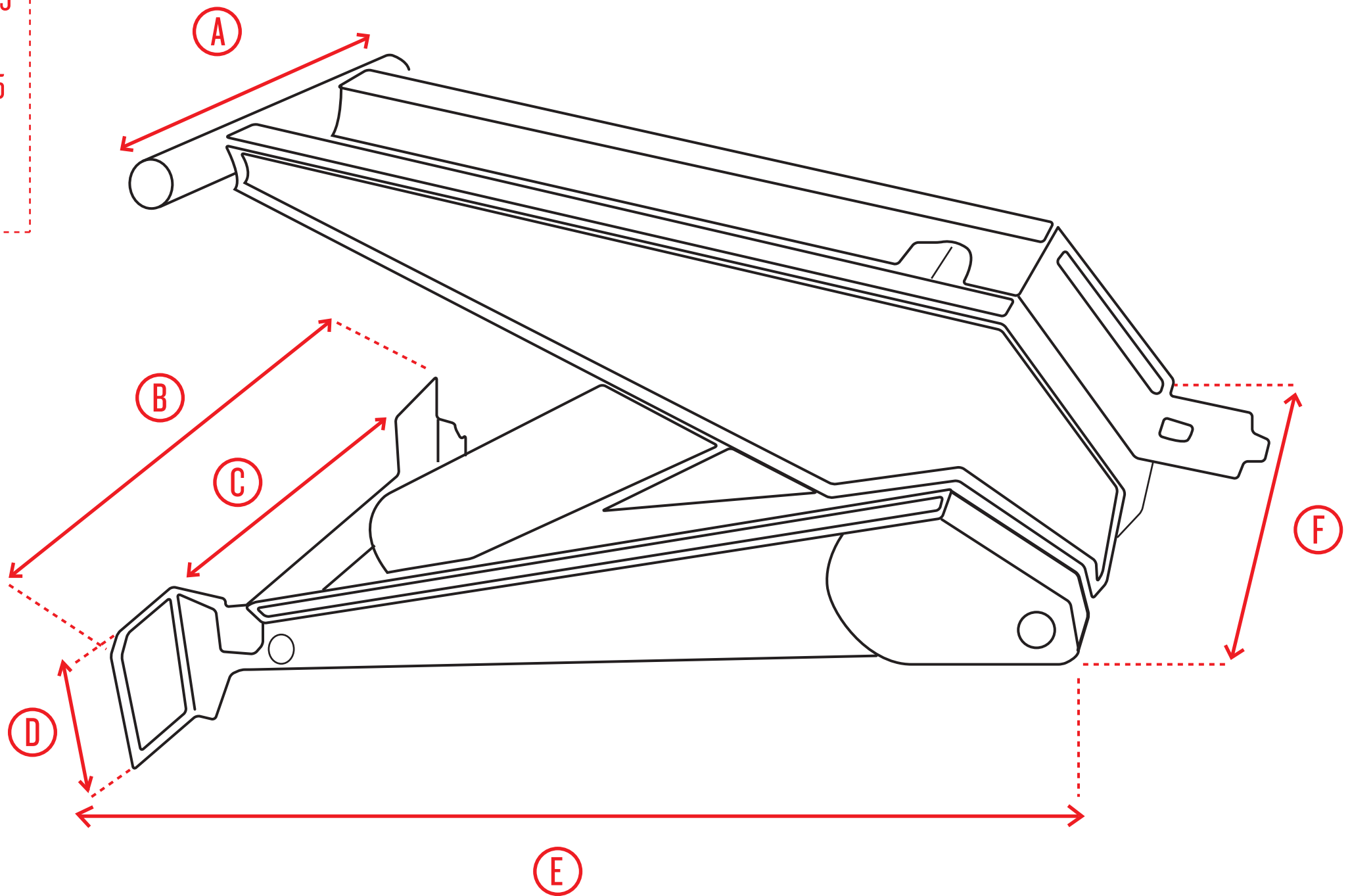

CLOSED HOIST

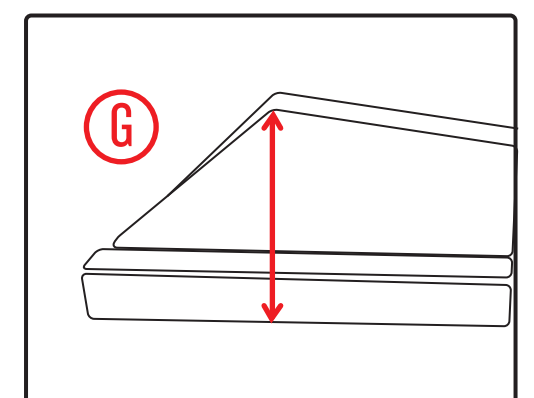

625
MODEL

POWER HOISTS

A=24
B=38
C=25.25
D=10
E=57.5
F=23
G=14

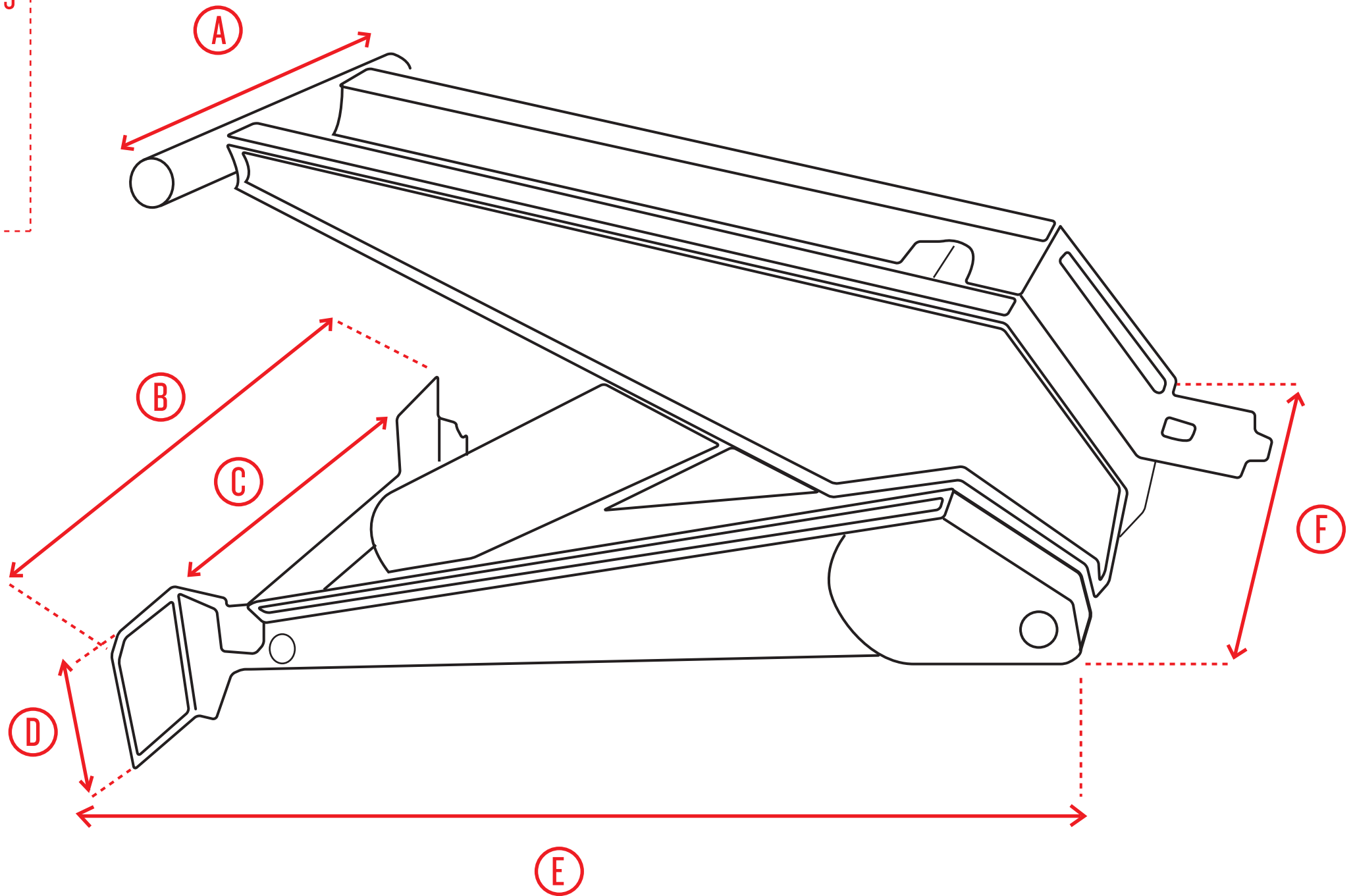

CLOSED HOIST

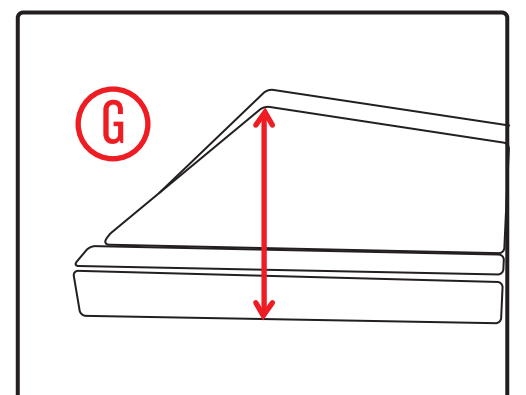

630
MODEL

POWER HOISTS

A=24

B=38

C=25.25

D=10

E=66

F=24

G=14.25

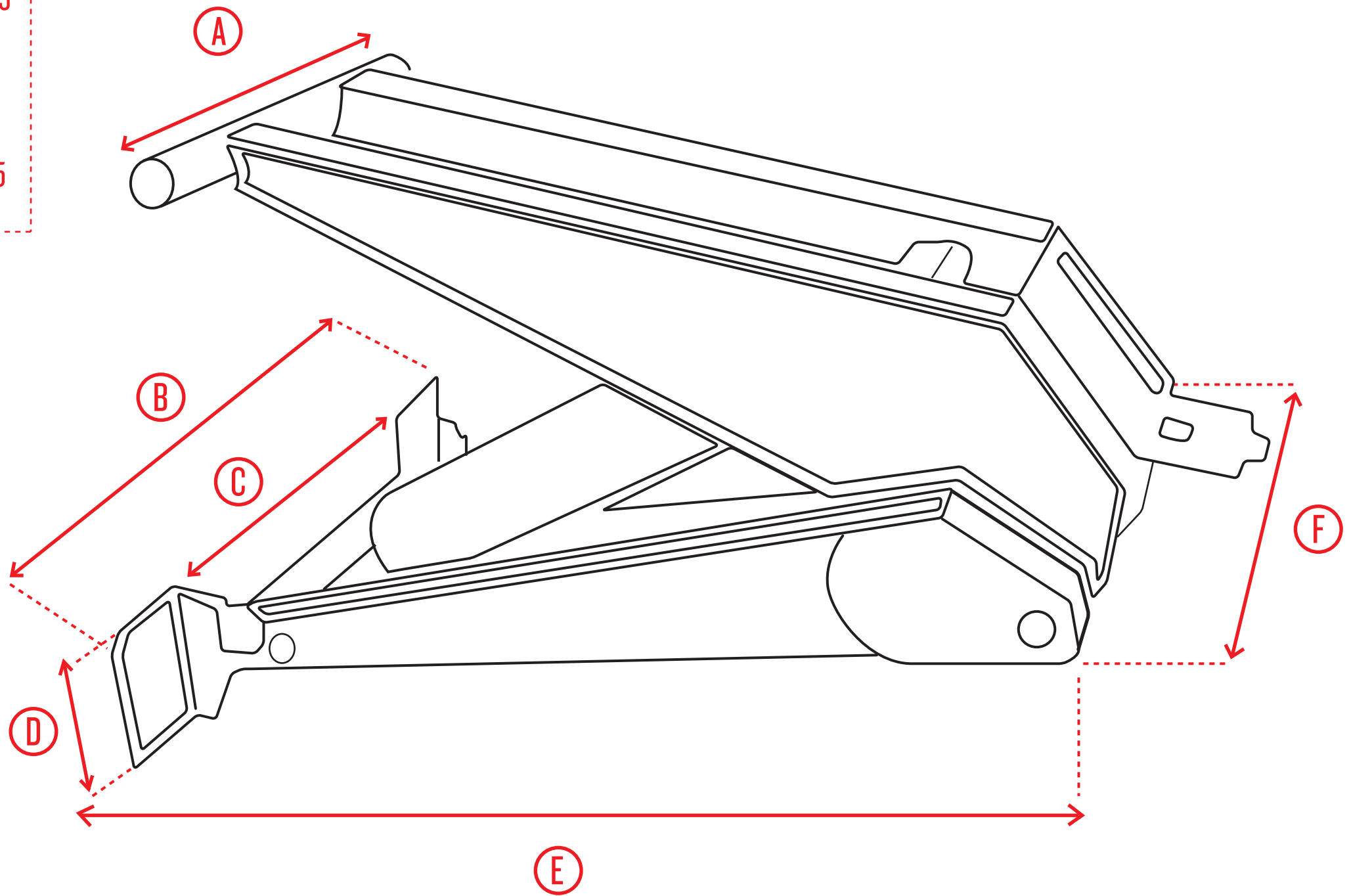

CLOSED HOIST

