

Premium Supply

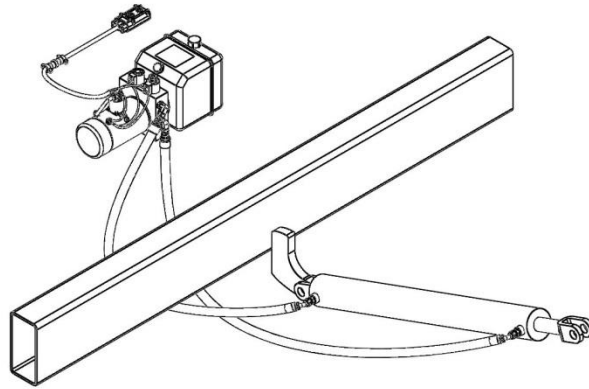

Direct Push

Models
PCK-3530-DP
PCK-3530-2DP
PCK-530-DP

Operator's Manual and Installation Instructions

Premium Supply
2038 West Interstate 30
Greenville, Texas
866-934-0777
Proud members of:



and



June 18, 2015

Table of Contents

Introduction	3
Important Information	3
Message to the Trailer Manufacturer	3
Weights.....	3
Warranty	4
Safety First.....	5
Safety Sign Locations	5
Safety Precautions	6
Parts Included in PCK-3530-DP Kit.....	7
Parts Included in PCK-530-DP Kit.....	8
Parts Included in Dual Push PCK-3530-DP Kit.....	9
Safety Arm Installation and Use	10
Hinge Installation and Lubrication	12
Cylinder Location on Trailer.....	13
Dual Acting Hydraulic Power Unit Installation	15
Hydraulic System Pre-Operation.....	15
Battery Hookup Double Acting HPU.....	18
PCK-3530-DP Trailer Application Data	18
Dual PCK-3530-DP Trailer Application Data.....	19
PCK-530-DP Trailer Application Data	20
Troubleshooting.....	21

Introduction

This manual covers proper cylinder installation, hydraulic connection, wiring and service of the Premium Supply models listed on the cover. **NOTICE: It is the end users responsibility to determine appropriate support member strength and weld size to properly support the load being lifted. Illustrations are for instructional purposes only.**

Important Information

Kit Serial Number	
Pump Installation and Operation Manual Number:	
In Service Date:	
Dealer:	
Address:	
City, State, Zip:	
Dealer Phone Number:	

Message to the Trailer Manufacturer

This manual contains instructions on how to correctly install and operate the direct push system. These instructions are generalized, as each trailer is manufactured differently.

This manual does not outline the operation of the hydraulic system, as there are many different types of hydraulic systems available and supplied by Premium Supply. **It is important that the hydraulic system operation manual be supplied to the end user, along with this manual.**

Some trailer manufactures will purchase and install a hydraulic system not supplied by Premium Supply. In this case, it is your responsibility to obtain the correct manual for the installation and operation of the hydraulic system. **The hydraulic system manual should be supplied along with this manual and made available to the end user.**

The safety signs supplied with the kit are general in nature and are for use with the kit. Because trailers vary between manufactures, it is the responsibility of the manufacturer, not Premium Supply, to ensure that correct safety signs and warnings are obtained.

Weights

PCK-530-DP
Kit: 147 lbs.

PCK-3530-DP
Kit: 98 lbs

PCK-3530-2DP
Kit: 135 lbs.

Warranty

Standard Warranty:

Premium Supply warrants your product to be free from defects in material and workmanship for a period of 36 months from the original date of purchase. If you discover a defect in a product covered by this warranty, we will repair at our option using new or refurbished components, or if repair is not possible, replace the item. This warranty is non-transferable.

Warranty Extension:

Premium Supply warrants for 5 years from the date of purchase any of its kits that have the three products listed below in the circuit and have a hydraulic fluid pre-filtration process in place. The hydraulic fluid must be pre-filtered while being put into the hydraulic pump reservoir, with a FPH cleanliness code of at least (ISO 4406) 15/12. All single acting circuits must be plumbed with a hydraulic hose going to both sides of the cylinder. (Contact Premium Supply for instructions on how to implement these quality control measures).

1. KTI power unit (single or double acting, "with a ground wire connected directly from the battery post to the electric motor of the pump").
2. Bridon Load Control Valve (on the load holding port)
3. SP-2 SolarPulse Solar Panel (mounted per our recommendation)

Exclusions:

This warranty covers defects in manufacturing discovered while using the product as recommended by the manufacturer. The warranty does not cover loss or theft, nor does coverage extend to damage caused by misuse, improper installation, abuse, unauthorized modification, improper storage conditions, or natural disasters. This warranty does not cover parts that are subject to normal wear and tear. Paint, finishes or paint preparation done by the customer are not covered under this warranty, nor is deterioration of the paint and appearance caused by normal wear and tear. This warranty becomes void upon modifications not authorized by Premium Supply.

Limits of Liability:

Should the product fail, your sole recourse is repair or replacement, as described in preceding paragraphs. Premium Supply will not be liable to you or any other party for damages resulting from failure of the product. Damages not covered by this warranty include, but are not limited to, lost profits, lost savings, damage to other equipment, incidental or consequential damages arising from the use or inability to use this product. In no event will Premium Supply be liable for more than the amount of your purchase price, not to exceed the current list price of the product and excluding tax, shipping and handling charges. By using this product, user accepts all terms stated herein.

Premium Supply reserves the right to make improvements to any model or product without notice. This warranty supersedes all previous warranties written or implied.

Safety First

 This symbol is used to call attention to instructions concerning personal safety. Be sure to observe and follow these instructions. Take time to be careful!

A brief description of signal words that are used in this manual follows:

 **DANGER** indicates an imminently hazardous situation which, if not avoided, WILL result in death or serious injury.

 **WARNING** indicates a potentially hazardous situation which, if not avoided, COULD result in death or serious injury and includes hazards that are exposed when guards are removed.

 **CAUTION** indicates a potentially hazardous situation which, if not avoided, MAY result in minor or moderate injury. It is also used to alert against unsafe practices.

Safety Sign Locations

Safety signs are included with the hoist kit purchased by you or the trailer manufacturer. Place these signs as shown below.

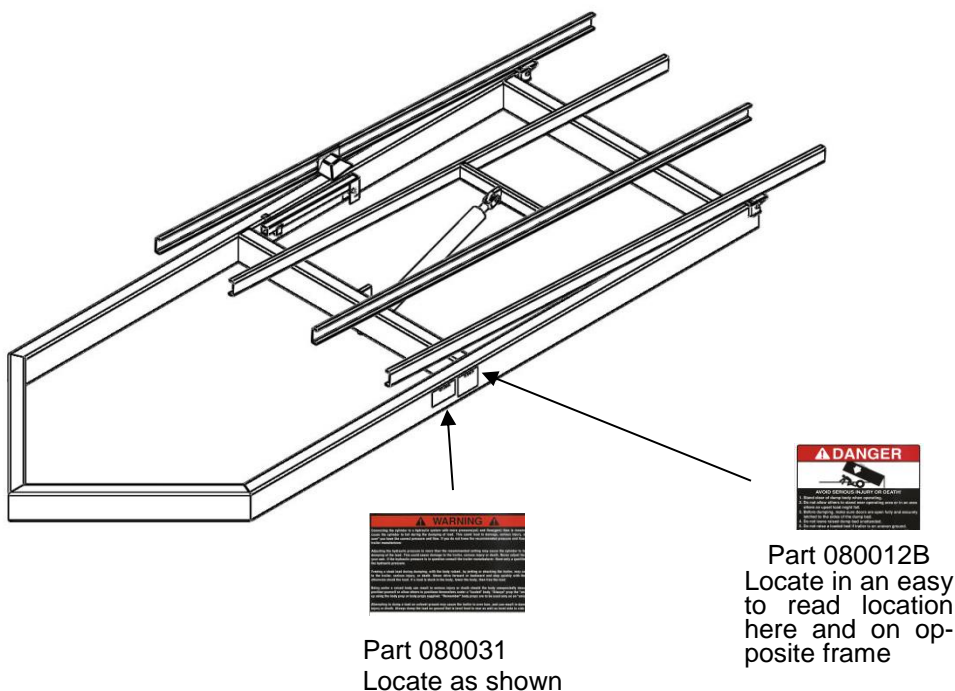

 Read all safety signs on the trailer and in this manual. Keep these signs clean and replace any lost or destroyed signs.

Safety Precautions

⚠️ WARNING Installing or operating this equipment without first understanding proper installation and operation procedures could lead to serious injury or death. Always read and fully understand all installation and operation manuals before installing or operating this equipment. Contact Premium Supply with any questions.

⚠️ WARNING Overloading a trailer could cause vehicle or trailer component damage resulting in injury or death. NEVER exceed the gross vehicle weight (GVW) or gross axle weight (GAW) rating of the trailer or your vehicle.

⚠️ WARNING Damage to brake lines during manufacturing and installation of this equipment, as well as installing any hardware (bolts, nuts, brackets) in a way that they may rub and damage the brake system, could lead to brake failure. This can cause an accident that could cause injury or death. ALWAYS take adequate steps to prevent brake system damage during installation of the equipment, and take precaution to ensure that installed equipment does not interfere with brake system.



⚠️ WARNING Malfunctioning equipment could cause property damage, injury or death. ALWAYS have faulty equipment repaired before continuing use. Consult the trailer manufacturer if required.

⚠️ WARNING Welding, oxy-fuel cutting, or grinding could cause fuel to ignite. This could lead to injury or death. ALWAYS take adequate steps to avoid the ignition of fuel from fuel tanks when welding, oxy-fuel cutting, and/or grinding during installation.

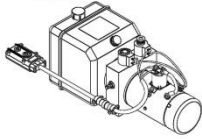
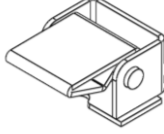
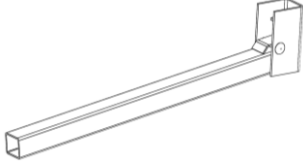
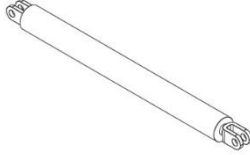
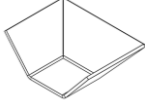
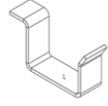
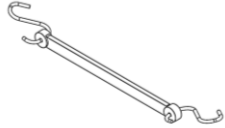
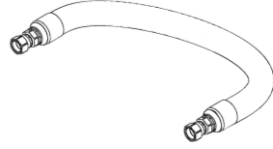
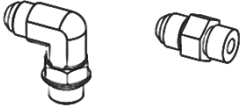
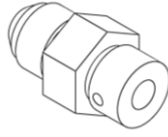

⚠️ WARNING Heat from the vehicles exhaust system could cause hydraulic component failure. This could lead to a fire that can lead to injury or death. ALWAYS install equipment in locations where the exhaust system heat will not damage any components critical to operation.

⚠️ WARNING Never attempt to jerk or shock the trailer body with the body raised to remove a stuck load. Jerking or shocking the trailer in this position can cause damage that could result in injury or even death. NEVER drive forward or reward and stop quickly to “un-stick” the load. If load is stuck, lower trailer body and free load

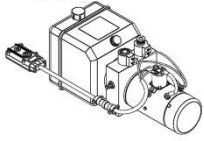
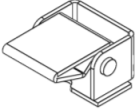
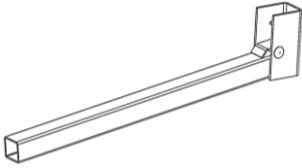
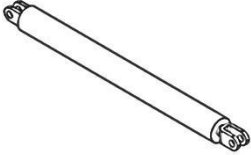
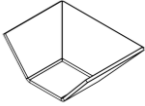
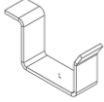
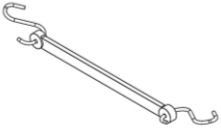
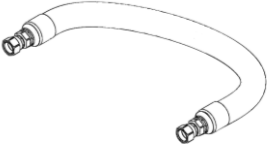
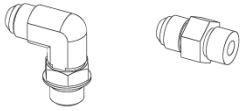
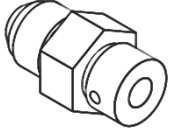

Parts Included in PCK-3530-DP Kit

 <p>Hydraulic Power Unit (HPU) Double Acting</p>	 <p>Two Hinges</p>
 <p>Safety Arm</p>	 <p>3.5 x 30 Cylinder Assembly</p>
 <p>Safety Arm Cup</p>	 <p>Safety Arm Storage Arm Bracket</p>
 <p>Rubber Battery Strap</p>	 <p>Hydraulic Hoses Between HPU & Cylinder One 3/8 x 110" long One 3/8 x 120" Long</p>
 <p>Hydraulic Fittings</p>	 <p>Bridon Load Control</p>
 <p>Two Battery Cables 2GA. X 16"</p>	 <p>Two Cylinder Supports</p>

Parts Included in PCK-530-DP Kit

 <p>Hydraulic Power Unit (HPU) Double Acting</p>	 <p>Two Hinges</p>
 <p>Safety Arm</p>	 <p>5 x 30 Cylinder Assembly</p>
 <p>Safety Arm Cup</p>	 <p>Safety Arm Storage Arm Bracket</p>
 <p>Rubber Battery Strap</p>	 <p>Hydraulic Hoses Between HPU & Cylinder One 3/8 x 110" long One 3/8 x 120" long</p>
 <p>Hydraulic Fittings</p>	 <p>Bridon Load Control</p>
 <p>Two Battery Cables 2GA. X 16"</p>	 <p>Two Cylinder Supports</p>

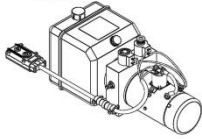
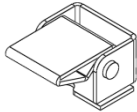
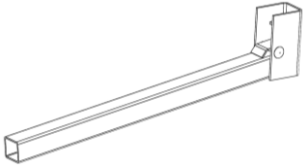
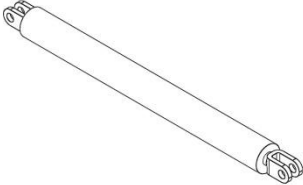
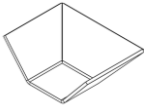
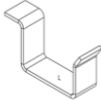
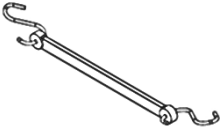
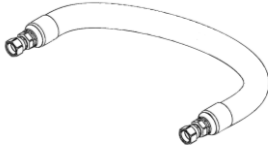
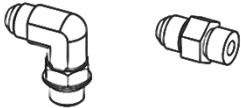
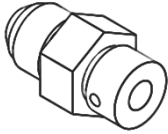
Parts Included in Dual Push PCK-3530-2DP Kit

 <p>Hydraulic Power Unit (HPU) Double Acting</p>	 <p>Two Hinges</p>
 <p>Safety Arm</p>	 <p>Two 3.5 x 30 Cylinder Assembly</p>
 <p>Safety Arm Cup</p>	 <p>Safety Arm Storage Arm Bracket</p>
 <p>Rubber Battery Strap</p>	 <p>Hoses Between HPU & Flow Divider/Tee Two 3/8 x 120" Long</p> <p>Hoses Between Flow Divider/Tee to Cyl. Four 3/8 x 48" Long</p>
 <p>Hydraulic Fittings</p>	 <p>Two Bridon Load Control</p>
 <p>Two Battery Cables 2GA. X 16"</p>	 <p>Two Cylinder Supports</p>

Safety Arm Installation and Use



Always support an unloaded body with the safety arm. The safety arm is meant to support the weight of an unloaded body only.



Being under a raised body could result in serious injury or death should the body unexpectedly descend. Never position yourself or allow others to position themselves under a loaded body. Always support an unloaded body with the supplied safety arm. NEVER use the safety arm on a loaded body.

Safety Arm Use:

- 1 Raise trailer body to sufficient height and shut off hydraulic power to hoist.
- 2 Grasp safety arm and rotate into the up/vertical position.
- 3 Once vertical position is accomplished, push arm down into the support bracket at base of arm.
- 4 **SLOWLY** lower the body until the cup contacts the vertical facing arm.
- 5 **NEVER HOLD DOWN THE DOWN BUTTON** on the remote control after the body contacts the safety arm. Doing so will bend the safety arm or bracket.
- 6 Reverse the above procedure to place arm back in its hanger for transport (be sure to body to full down position upon placing arm back in hanger).

Maximum Unloaded Tilt Body Weight in Pounds Using One Safety Arm

		Trailer tilt body length in feet						
		8	10	12	14	16	18	20
Distance between rear hinge and safety arm in inches	50	3854	3083	2569	2202	1927	1713	1542
	60	4625	3700	3083	2643	2313	2056	1850
	70	5396	4317	3597	3083	2698	2398	2158
	80	6167	4933	4111	3524	3083	2741	2467
	90	6938	5550	4625	3964	3469	3083	2775
	100		6167	5139	4405	3854	3426	3083
	110		6783	5653	4845	4240	3769	3392
	120		7400	6167	5286	4625	4111	3700
	130			6681	5726	5010	4454	4008
	140			7194	6167	5396	4796	4317
	150				6607	5781	5139	4625
	160				7048	6167	5481	4933
	170					6552	5824	5242
	180					6938	6167	5550
	190					7323	6509	5858
	200						6852	6167
	210						7194	6475
220							6783	
230							7092	

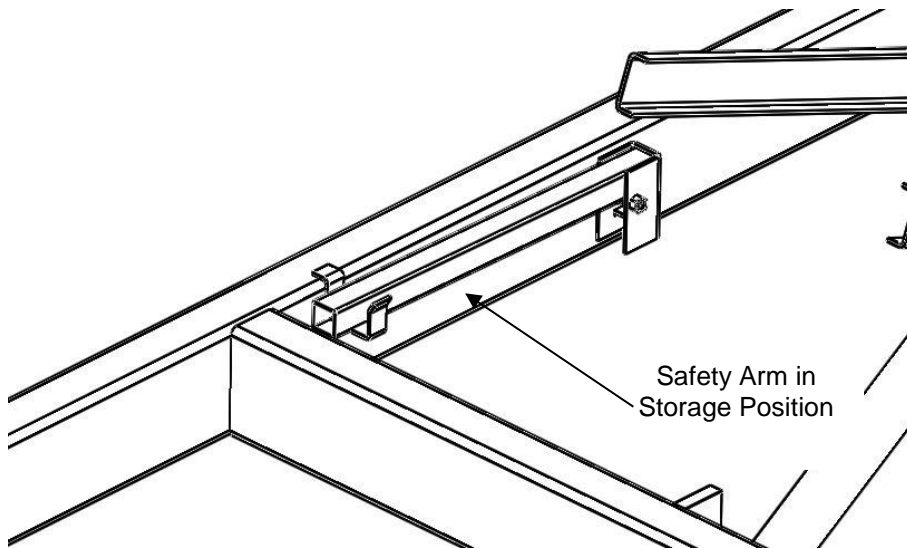
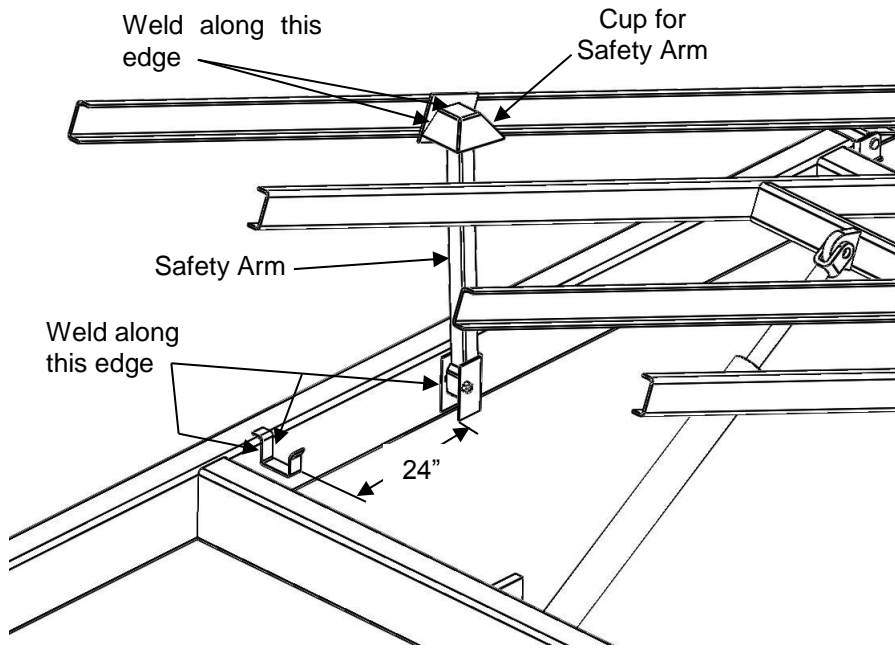

Hinge Installation and Lubrication

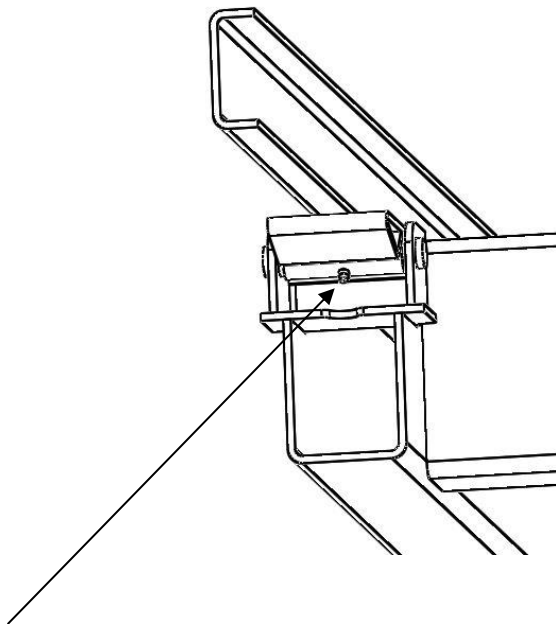
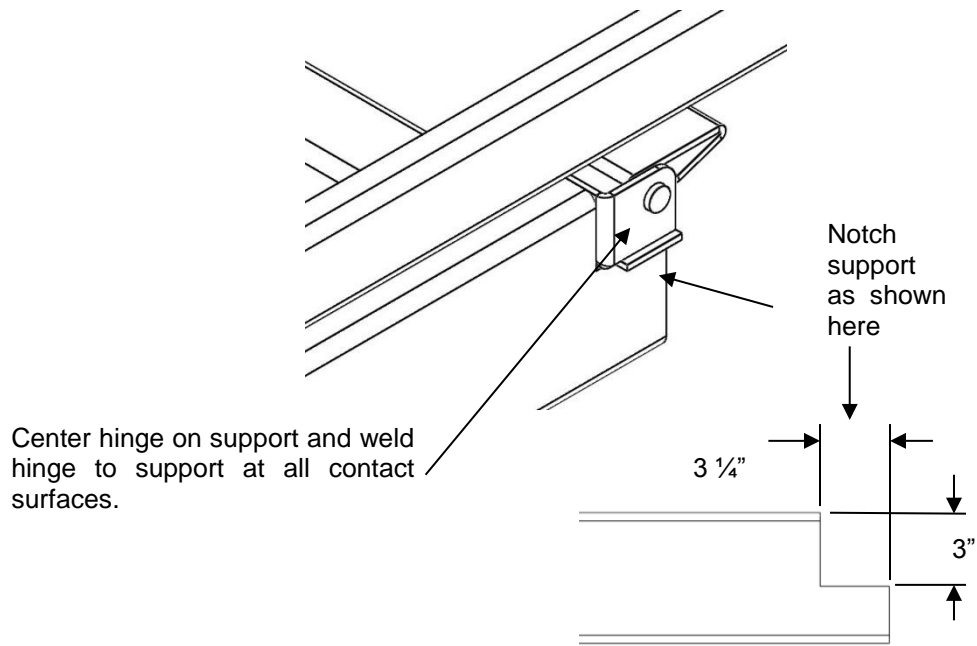

Lubricate the joint with EP3 grease every 6 months

Cylinder Location on Trailer

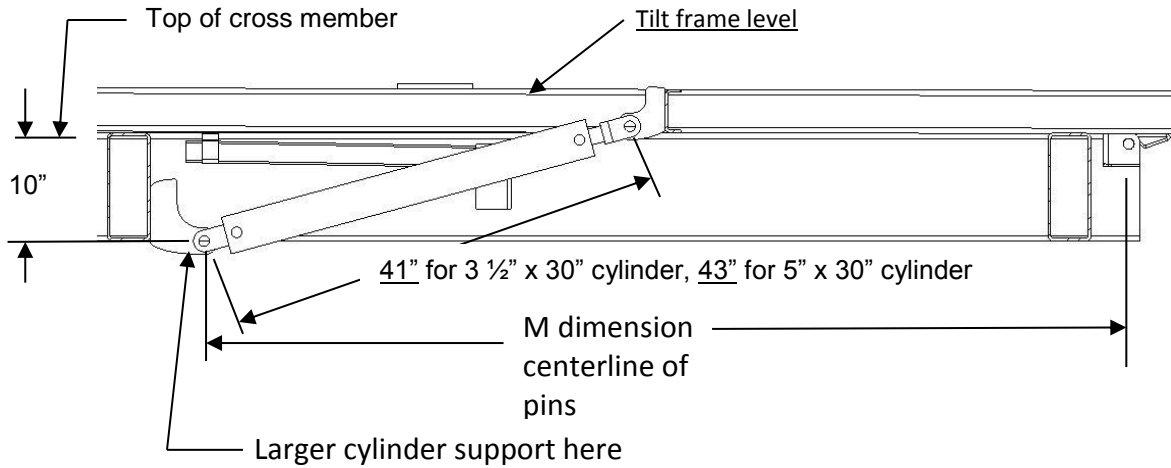

Maximum Dump Angle $\pm 2^\circ$	"M" Dimension
25	125
30	110
35	99
40	91
45	86
50	79

! WARNING The PCK-3530 DP cylinder is capable of 31,000 lbs of push and the PCK-530-DP cylinder is capable of 63,000 lbs of push. Improper sizing, mounting and welding of the cylinder supports could result in support failure.

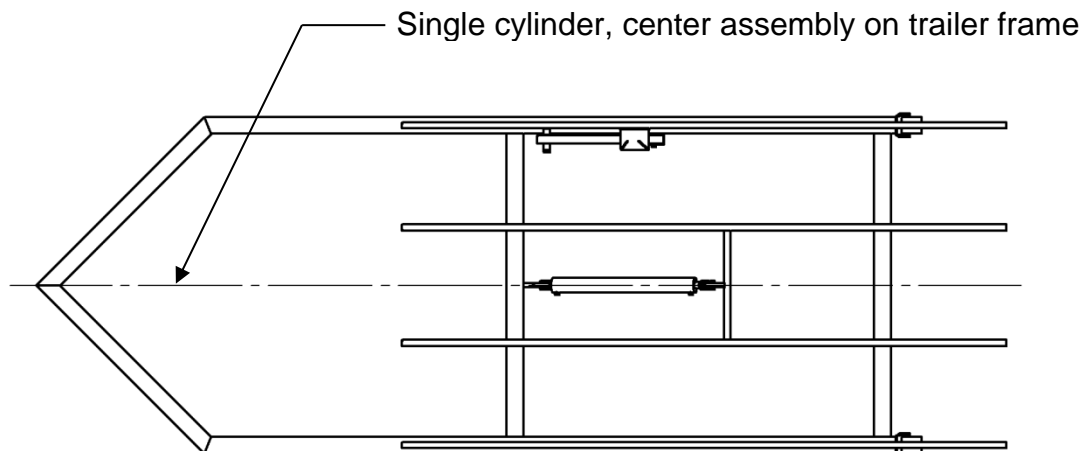

complete trailer assembly DP top view

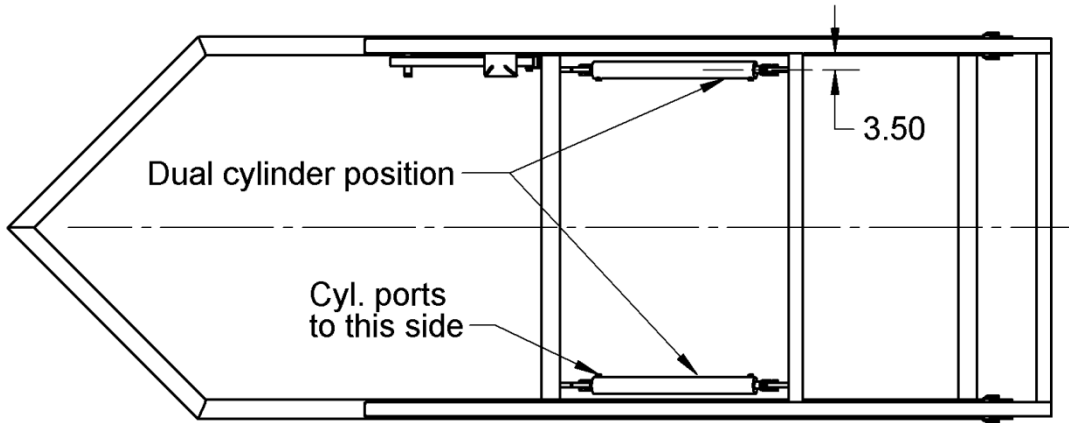

Dual Acting Hydraulic Power Unit Installation

Mount HPU (hydraulic power unit) in a weather tight enclosure on the trailer. See additional instructions supplied with the HPU for mounting, electrical, wireless remote and hydraulic fluid requirements.

All HPU, hoses and fittings between HPU and cylinder are supplied by Premium Supply.

⚠ CAUTION If hydraulic components other than those supplied by Premium Supply are used in the hydraulic circuit, it is the purchaser's responsibility to verify that the components are compatible with the components supplied by Premium Supply. Incompatible components may cause failure of the direct push cylinder that, in turn, may cause damage to the trailer, vehicle, other property, and may cause injury or death.

⚠ WARNING Connecting the cylinder to a hydraulic system with more pressure (PSI) or flow (GPM) than is recommended by Premium Supply could cause the cylinder to fail during operation. This could lead to damage, serious injury, or death. Be sure you have correct pressure and flow before operation. Consult Premium Supply if you are unsure about your hydraulic system.

⚠ WARNING Adjusting the hydraulic pressure to more than the recommended setting could cause the cylinder to fail during operation. This could cause damage, serious injury, or death. NEVER adjust the pressure on your own. Consult the trailer manufacturer if the hydraulic pressure is in question. Only qualified personnel should adjust the hydraulic pressure. NEVER adjust the pressure to more than the recommended amount.

Hydraulic System Pre-Operation

The hydraulic system supplied with the trailer direct push system supplied by Premium Supply consists of components (pump, valves, reservoir, hoses, cylinder, etc.) that are designed to be compatible with each other.

All Premium Supply's trailer direct push system liability and warranty will be voided if determined by Premium Supply that substituted hydraulic components were used that were incompatible with those supplied by Premium Supply.

Direct push parameters are listed on the next page. These are listed as a general guide to ensure proper compatibility (when using other hydraulic components). If you have any questions, please contact Premium Supply.

Body Up Hose Assy.

110x3/8 (Supplied)

Port "A" On hydraulic power unit 3200 PSI

Body Down Hose Assy.

120"x3/8 (Supplied)

Port "B" On hydraulic Power unit 1500PSI

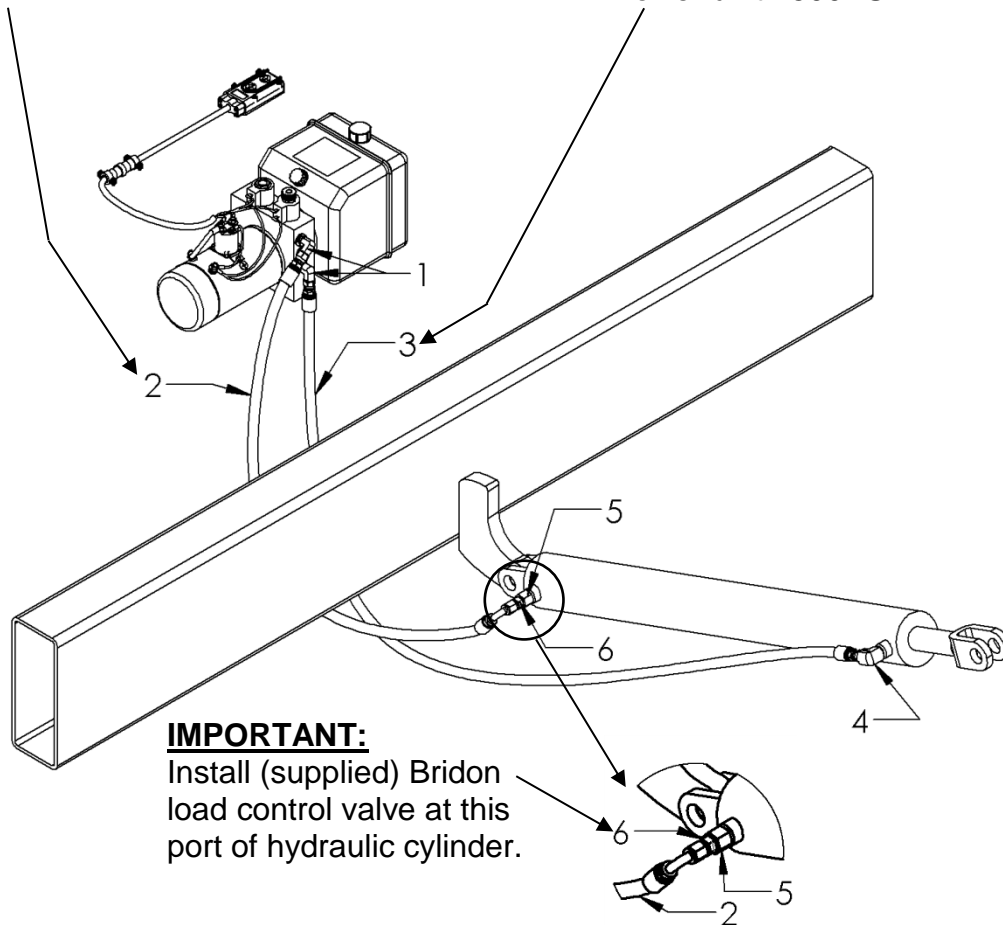

IMPORTANT:
Install (supplied) Bridon load control valve at this port of hydraulic cylinder.

Maximum Hydraulic Flow Rate	2 GPM	Port
Maximum Pressure For "Raising" Portion of Cycle	3200 PSI	A
Maximum Pressure For "Lowering" portion of Cycle	1500 PSI	B

Item	Qty.	Part Number	Description
1	2	6801-06-06-FG	Fitting, #6 SAE Male x #6 JIC Male 90 Degree
2	1	6FJ-9017-6FJ90T-110"	Hose Assy, 110" x 3/8" Hyd. 4000PSI
3	1	6FJ-9017-6FJ-120"	Hose Assy, 120" x 3/8" Hyd. 4000PSI
4	1	2501-06-08-FG	Fitting, 1/2 NPT Male x #6 SAE Male 90 Degree
5	1	6404-06-08	Fitting, 1/2 NPT Male x #6 SAE Female Reducer
6	1	06-250-12-3.5	Bridon Load Control

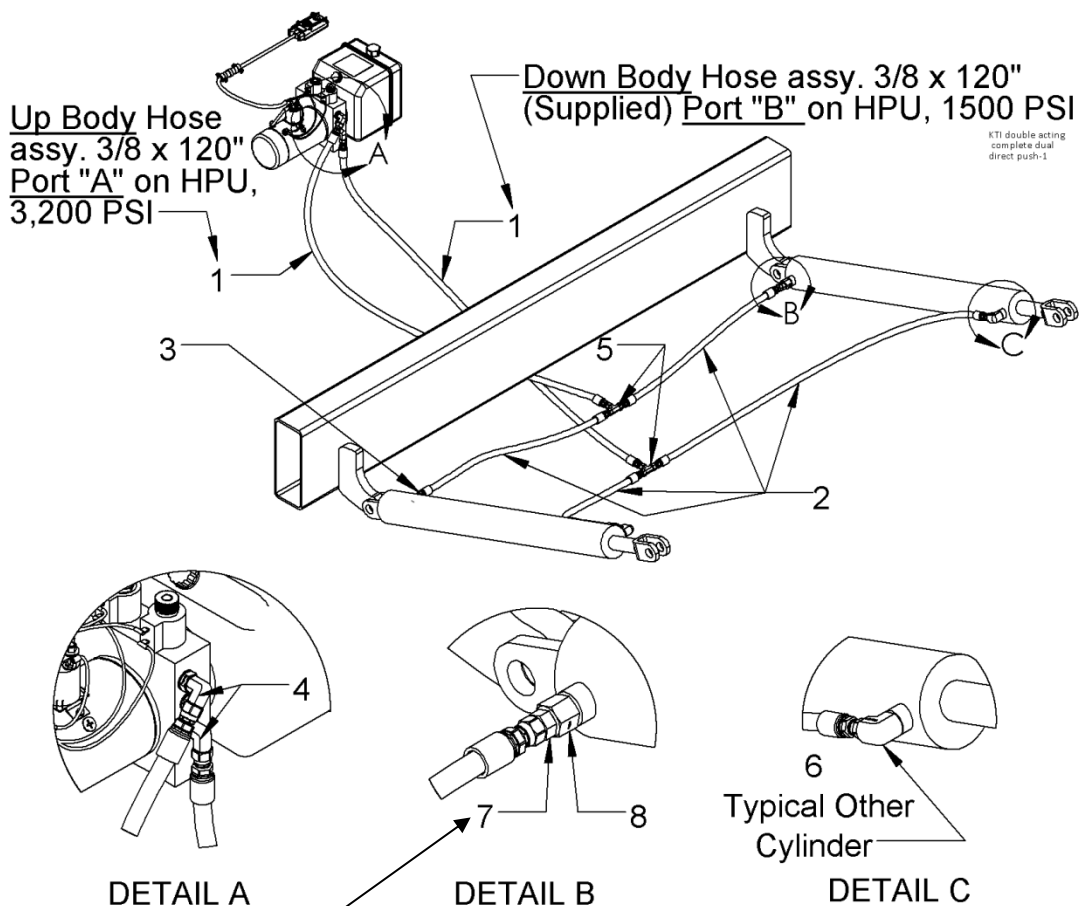

IMPORTANT:
Install (supplied) Bridon load control valve at this port of hydraulic cylinder.

Maximum Hydraulic Flow Rate	2 GPM	Port
Maximum Pressure For "Raising" Portion of Cycle	3200 PSI	A
Maximum Pressure For "Lowering" portion of Cycle	1500 PSI	B

Item	Qty.	Part Number	Description
1	2	6FJ-9017-6FJ-120"	Hose Assy., 120" x 3/8 Hyd. 4000 Psi.
2	4	6FJ-9017-6FJ-48"	Hose Assy., 48" x 3/8 Hyd. 4000 Psi.
3	1	2404-06-08	Fitting, 1/2 NPT Male x #6 JIC Male Straight
4	2	6801-06-06-FG	Fitting, #6 SAE Male x #6 JIC Male 90 Degree
5	2	2603-06-06-06-FG	Fitting, #6 JIC Tee
6	2	2501-06-08-FG	Fitting, 1/2 NPT Male x #6 SAE Male 90 Degree
7	1	06-250-12-3-5	Bridon Load Control
8	1	6404-06-08	Fitting, 1/2 NPT Male x #6 SAE Female Reducer

Battery Hookup Double Acting HPU

⚠️ WARNING

Shorting of the electrical system could cause a fire or equipment damage that could lead to injury or death. ALWAYS disconnect the battery prior to installing, servicing, or repairing power unit.

Mount battery in a weather tight enclosure on the trailer. See additional instructions supplied with the HPU for mounting, electrical and hydraulic fluid requirements.

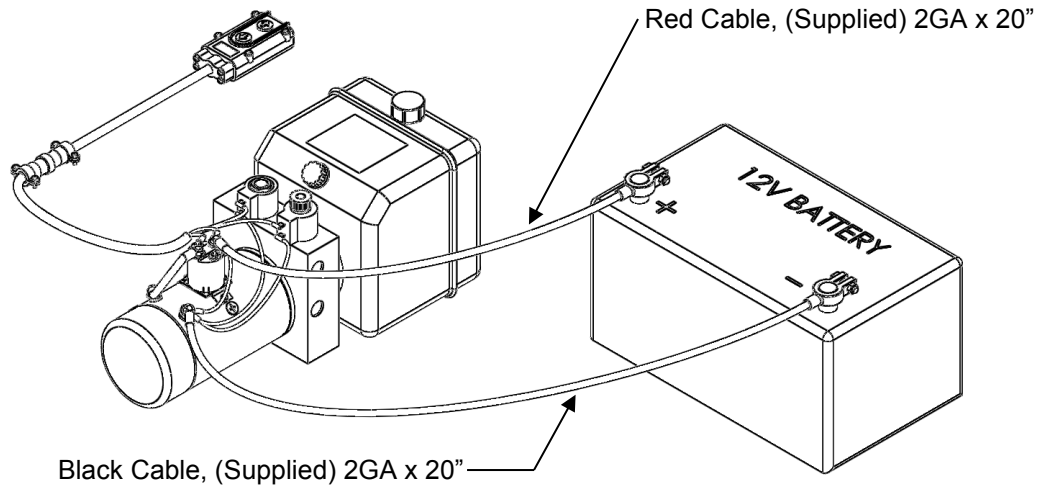

It is highly recommended that the trailer battery be kept charged using one of the Pulsetech products shown on Premium supply website at <http://www.premium-supply.com/>

PCK-3530-DP Trailer Application Data

		Capacity in Tons	
Trailer Length "A"	Overhang "B"	Dump Angle 45 Deg	Dump Angle 50 Deg
8'	12"	6.6	5.7
9'	12"	5.7	5.0
9'	18"	6.6	5.7
10'	12"	5.0	4.3
10'	18"	5.6	5.0
10'	24"	6.5	5.7
12'	12"	4.0	3.4
12'	18"	4.4	3.8
12'	24"	4.9	4.3

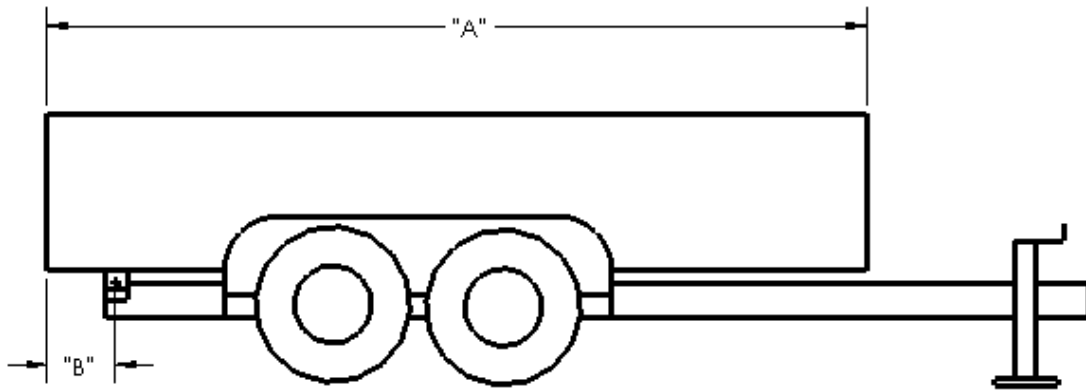

Capacities are based on the following:

1. Water level non-diminishing load.
2. The vertical height between the rear hinge pivot and the floor is no less than 3 inches.
3. The hydraulic relief pressure set at 3,200 psi.

PCK-3530-2DP Trailer Application Data

		Capacity in Tons	
Trailer Length "A"	Overhang "B"	Dump Angle 45 Deg	Dump Angle 50 Deg

8'	12"	13.2	11.4
9'	12"	11.4	10
9'	18"	13.2	11.4
10'	12"	10.0	8.6
10'	18"	11.2	10.0
10'	24"	13.0	11.4
12'	12"	8.0	6.8
12'	18"	8.8	7.6
12'	24"	9.8	8.6

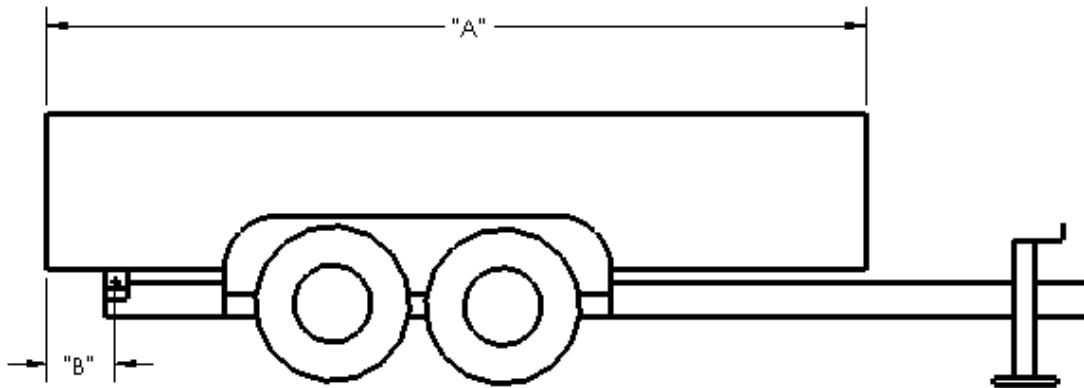

Capacities are based on the following:

1. Water level non-diminishing load.
2. The vertical height between the rear hinge pivot and the floor is no less than 3 inches.
3. The hydraulic relief pressure set at 3,200 psi.

PCK-530-DP Trailer Application Data

Trailer Length	Overhang	45 Deg	50 Deg
10'	12"	9.6	8.7
10'	18"	11.0	9.9
10'	24"	12.8	11.6
12'	12"	7.6	6.9

12'	18"	8.5	7.7
12'	24"	9.6	8.7
14'	12"	6.4	5.8
14'	18"	6.9	6.3
14'	24"	7.6	6.9

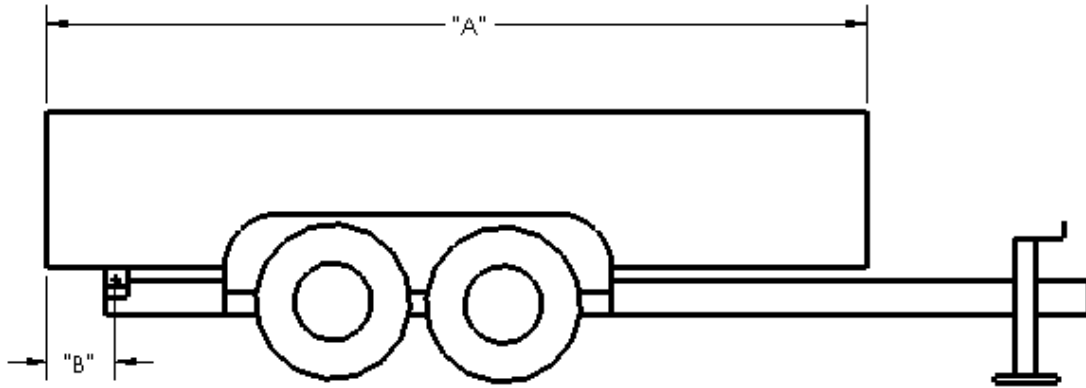

Capacities are based on the following:

1. Water level non-diminishing load.
2. The vertical height between the rear hinge pivot and the floor is no less than 3 inches.
3. The hydraulic relief pressure set at 3,200 psi.

Troubleshooting

Possible Cause	Problem														
	Not Building Pressure	Motor Not Running	Cylinder Won't Extend	Cylinder Won't Retract	Won't Hold Load	Excessive Heat From Unit	Aeration of Hyd. Fluid	Reservoir Overflows	Struggles to Lift Load	Load Bounces When Cylinder Retracts	Start Solenoid Just Click-Motor Not Engaging	Won't Lift Load (DC Motor Under Load)	Won't Lower	Start Solenoid Stays On	Cylinder Won't Retract (Motor Under Load)
Low Battery Voltage		<input type="checkbox"/>	<input type="checkbox"/>	<input type="checkbox"/>		<input type="checkbox"/>			<input type="checkbox"/>		<input type="checkbox"/>				
Poor Ground Condition		<input type="checkbox"/>	<input type="checkbox"/>	<input type="checkbox"/>		<input type="checkbox"/>			<input type="checkbox"/>		<input type="checkbox"/>				
Check Hand Control											<input type="checkbox"/>		<input type="checkbox"/>		<input type="checkbox"/>
Debris in Load Holding Valve					<input type="checkbox"/>										
Coil Not Energizing			<input type="checkbox"/>	<input type="checkbox"/>								<input type="checkbox"/>	<input type="checkbox"/>		<input type="checkbox"/>
Bad Seals in Cylinder	<input type="checkbox"/>									<input type="checkbox"/>					<input type="checkbox"/>
Loose Inlet				<input type="checkbox"/>			<input type="checkbox"/>			<input type="checkbox"/>					<input type="checkbox"/>
Hoses Connected Backwards										<input type="checkbox"/>					
Pump Not Priming	<input type="checkbox"/>		<input type="checkbox"/>												
Clogged Orifice				<input type="checkbox"/>									<input type="checkbox"/>		<input type="checkbox"/>
Rust in Motor		<input type="checkbox"/>													
Check for Additional Valving On or Connected to Cylinder					<input type="checkbox"/>										<input type="checkbox"/>
Directional Valve Not Shifting Properly			<input type="checkbox"/>	<input type="checkbox"/>					<input type="checkbox"/>				<input type="checkbox"/>		<input type="checkbox"/>
Bad Start Solenoid											<input type="checkbox"/>		<input type="checkbox"/>	<input type="checkbox"/>	
Dirty Contacts in Hand Control				<input type="checkbox"/>							<input type="checkbox"/>	<input type="checkbox"/>			
Reservoir More Than ½ Full with Cylinder Fully Extended								<input type="checkbox"/>							