

# FLEET ENGINEERS

1800 EAST KEATING AVENUE  
MUSKEGON, MI 49442  
PH: 1-800-333-7890 • F: 231-777-2720

Installation Sheet #INS-01017

## Spray Master® FR-22 Fender Installation Instructions

### NOTE:

These instructions for installing Spray Master® FR-22 fenders are intended to be a general guide to help the installer. Because of the large number of possible mounting configurations, the installer is responsible for the installation design and for providing adequate clearance around the tire carrier (i.e. tire clearance, trailer clearance, etc.) This product may not fit all truck models or types of suspensions. Check truck or trailer manufacturer for suspension travel specifications. Modifications to the brackets and/or the fenders may be required. Any modifications are at the discretion, responsibility and risk of the installer.

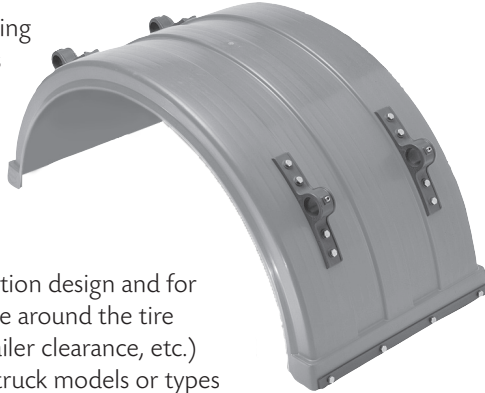

### Step 1

**Position fender over tires.** Use a 2x4 block or other suitable spacer to achieve desired clearance around tires. (S.A.E. Recommendation is 3" minimum).

### NOTE:

If you have an air suspension make sure there is tire clearance when the suspension is deflated.

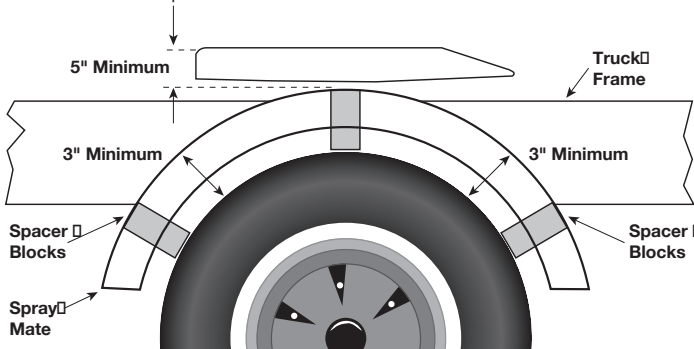

### Step 2

Assemble the Spray Master® FR-22 mounting clamps by inserting the threaded T-nuts into the clamps from the inside and pushing them into place.

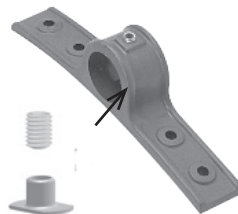

### Step 3

**Insert the mounting tubes through the mount supports.** Position the tube mounts approximately 12-18" from the ends of the Spray Master® FR-22, keeping them as square to the fender and truck frame as possible. Move the mount up and down on the fender. Select a space to drill a proper size mounting bolt hole/holes or see if an existing hole could be used.

### NOTE:

Be sure to follow truck or trailer manufactures recommended procedures for drilling any required holes in the frame.

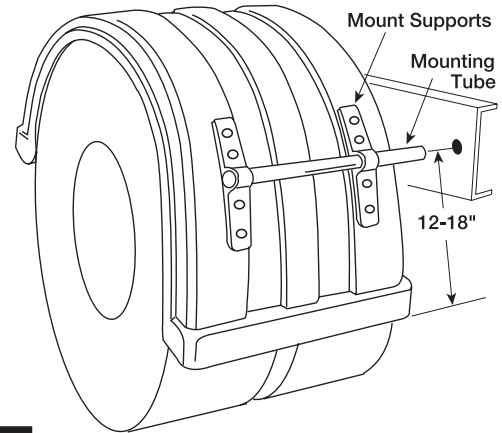

### Step 4

Bolt the mounting tubes to the truck or trailer frame using the appropriate torque for the size and grade of mounting bolts:

|           |              |           |              |
|-----------|--------------|-----------|--------------|
| 3/8-16 G8 | 50 Ft. Lbs.  | 3/8-16 G5 | 38 Ft. Lbs.  |
| 5/8-11 G8 | 245 Ft. Lbs. | 5/8-11 G5 | 175 Ft. Lbs. |
| 3/4-10 G8 | 425 Ft. Lbs. | 3/4-10 G5 | 300 Ft. Lbs. |

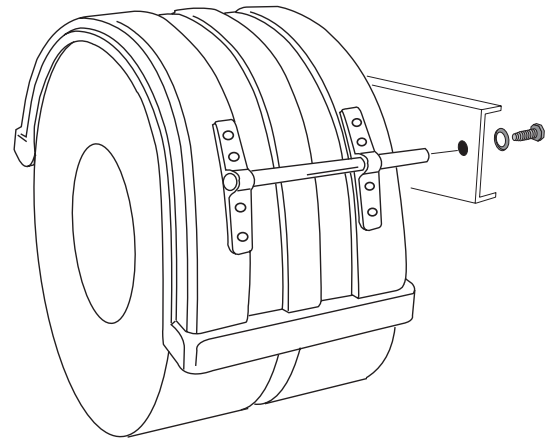

### Step 5

Move the fender into the desired position, adjusting spacers to hold the fender firmly against the mount supports.

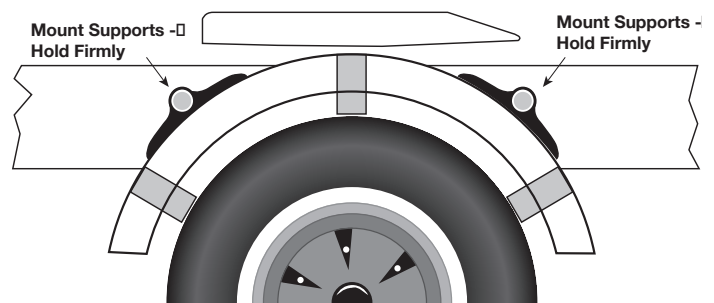

## Step 6

Slide the mount supports on the mounting tubes so they line up with the support strap that fits between ribs 4 and 5 counting in from the outside edge of the fender (approx. 4-7/8" in from the outside edge of the fender).

Now tighten the mount support set screw to

48 in. lbs.  
+/- 3in. lbs.  
or 4 ft. lbs.

**CAUTION: Do not over tighten.**

### NOTE:

The channels between ribs 4 and 5 is larger than the other spaces.

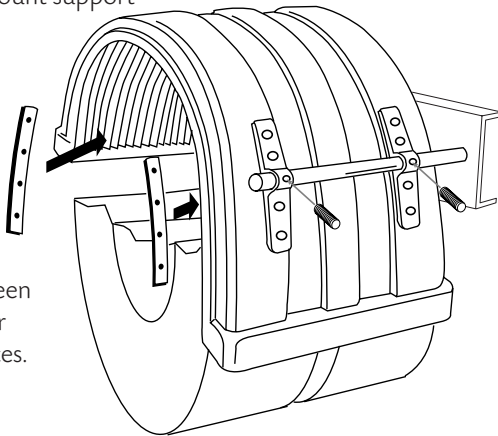

## Step 7

Spot the mounting bolt holes through the mount supports. Now drill 13/32 in. dia. holes through the fender.

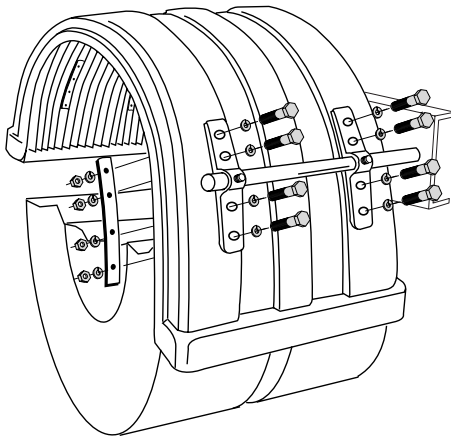

## Step 8

Fasten the mount support, fender and support strap together with the supplied hardware.

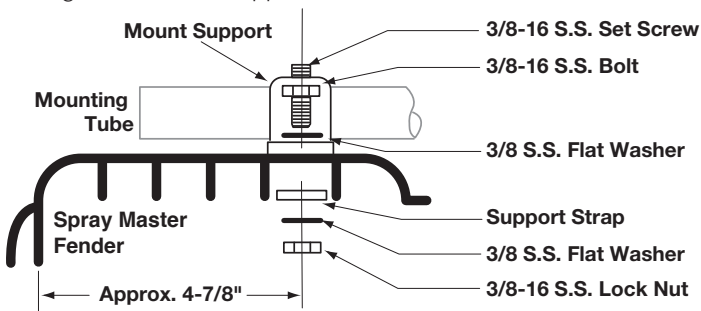

### NOTE:

Flap weights are not recommended and may void the warranty.

Painting Spray Master® fenders IS NOT recommended and may void the warranty. If painting is desired, a Flex Agent **MUST** be added to the paint!



## Spray Master® FR-22 Optional Accessories

### Mounting Options



### Conspicuity End Mount Plate

part #031-01583

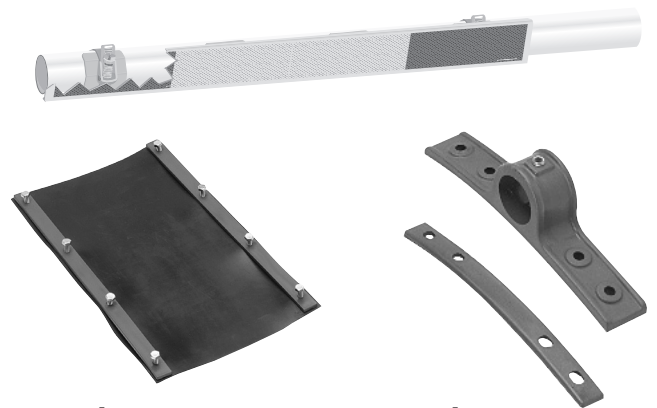

### Fender Connector

part #031-00828

### Fender Support

part #031-00823



### Curved Brush

part #031-01536

### Flap Reinforcing Strap

part #033-04139