

BLANK VIEW

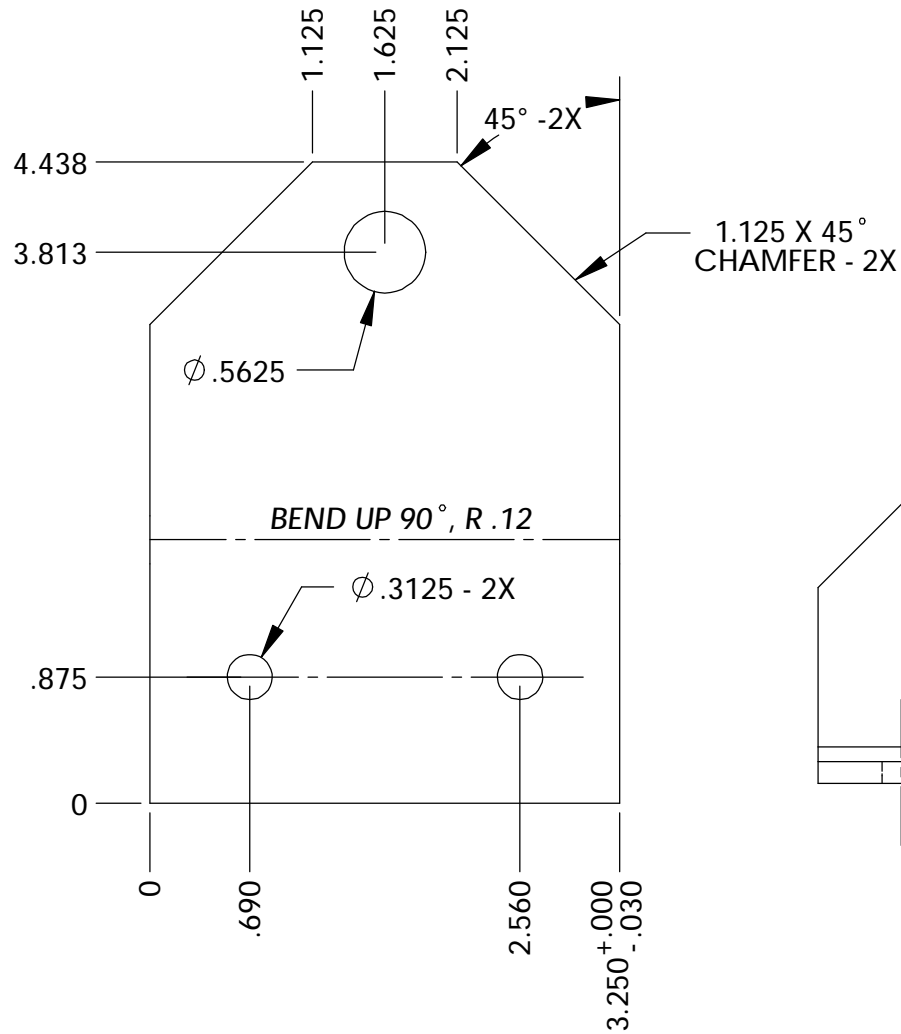

FORMED VIEW

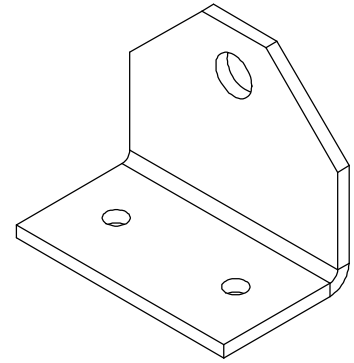
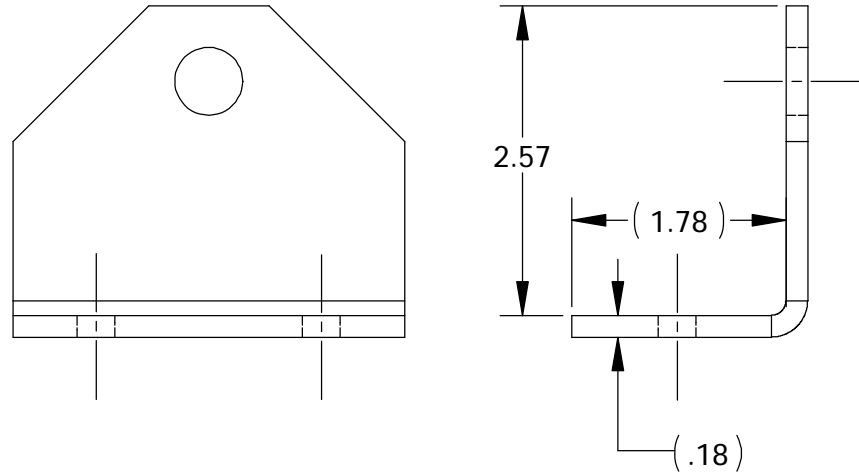

NOTE:

- 1.) TUMBLE
- 2.) USE DIE# PP-85

ALL DIMENSIONS ARE IN INCHES UNLESS OTHERWISE STATED
 TOLERANCES EXCEPT AS NOTED
 DECIMALS:
 .X ±0.100
 .XX ±0.060
 .XXX ±0.030
 .XXXX ±0.010
 ANGLES:
 ±1°
 ALL FORMED ANGLES
 EQUAL 90° UNLESS
 NOTED OTHERWISE
 () INDICATES REFERENCE

THE INFORMATION IN THIS DRAWING IS THE SOLE PROPERTY OF KARAVAN TRAILERS, INC. ANY REPRODUCTION IN PART OR WHOLE WITHOUT THE WRITTEN PERMISSION OF KARAVAN TRAILERS, INC. IS PROHIBITED.

APPROVED BY:
 DRAWN BY:
 DATE: 01-12-94
 SHEET: 1 OF 1
 SCALE: N/A

KARAVAN

TITLE: BUNK BRACKET
 (2.57" PIVOT)
 MAT'L: 7GA H.R.P.O. SHEET
 FINISH: - Z
 DWG. #: 100-00406

E	12431	JRN	02-20-03	ADDED +.000 -.030 TOLERANCE TO 3.250 DIMENSION
D	11324	ALT	02-01-00	SHEAR DIMENSIONS - NOW THREE DECIMAL PLACES (+/- .030) WAS TWO DECIMAL PLACES (+/- .060)
DWG. REV.	ECR/NDR NUMBER	REVISED BY	DATE	DESCRIPTION

First Piece - In Process Inspection Sheet

Vendor _____

Description: **Bunk Bracket**

Part # **100-00406**

Rev. **E**

QA Approval: K. Baumhardt

JOB# _____

Characteristic	Tol.	Method	Freq.	1st Piece	A/R	2	A/R	3	A/R	4	A/R	5	A/R	6	A/R	7	A/R	Inspected By/Date:	
LASER																			1 /
7 GA	.171- .187	Mic.	1st/Last Piece																2 /
H.R.P.O.	NA	Visual	1st/Last Piece																3 /
4.438	±.030	Caliper	1st/Last Piece																4 /
3.250	+ .000 - .030	Caliper	1st/Last Piece																5 /
Ø.5625	±.010	Caliper	1st/Last Piece																6 /
Ø.3125 - 2X	±.010	Caliper	1st/Last Piece																7 /
FORM																			
2.57	± .060	Caliper	1:100																
Inspect parts for scratches, dents, gouges, etc.	NA	Visual	Every piece																
No slugs left in lasered holes.	NA	Visual	Every piece																