

FLAT VIEW

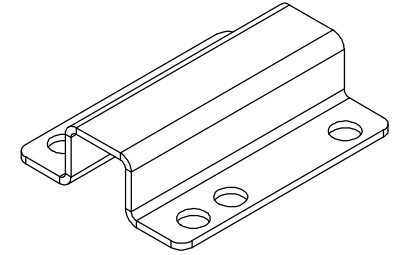

FORMED VIEWS

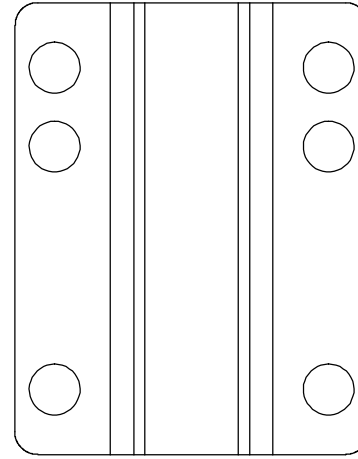
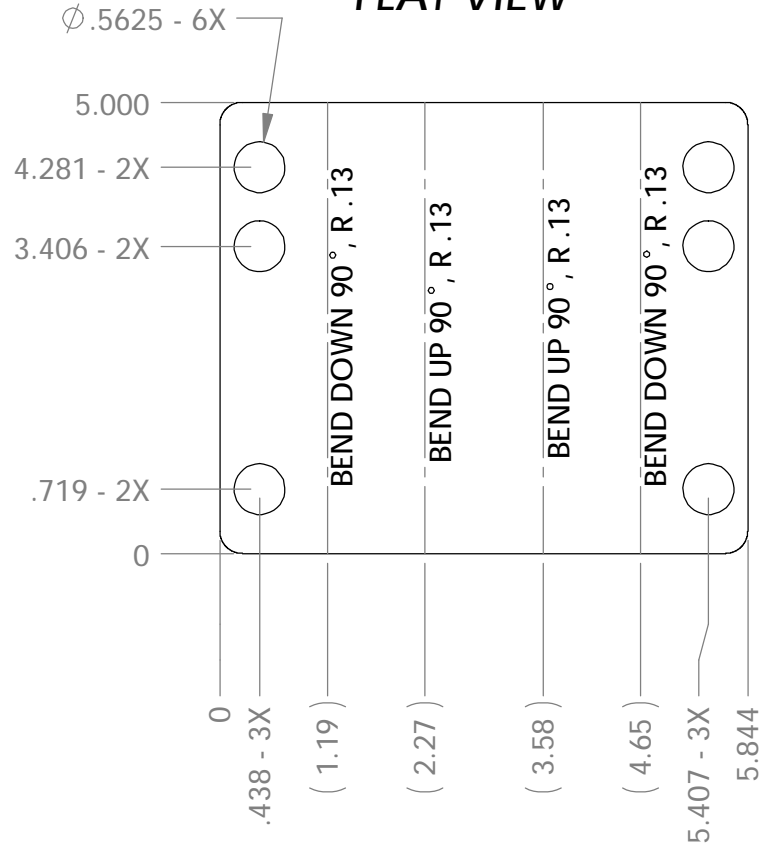
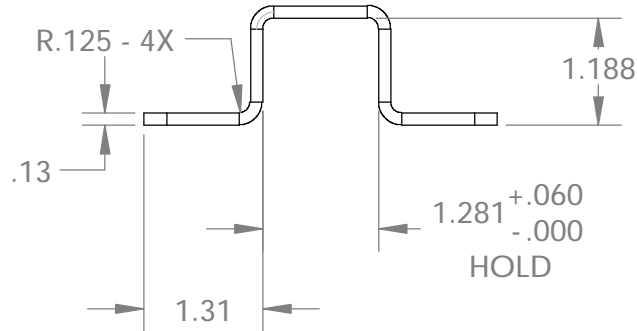

ALL DIMENSIONS ARE IN INCHES
UNLESS OTHERWISE STATED
TOLERANCES EXCEPT AS NOTED
DECIMALS:

.X ± 0.100
.XX ± 0.060
.XXX ± 0.030
.XXXX ± 0.010

ANGLES:
 $\pm 1^\circ$

ALL FORMED ANGLES
EQUAL 90° UNLESS
NOTED OTHERWISE

() INDICATES REFERENCE

THE INFORMATION IN THIS DRAWING IS THE SOLE
PROPERTY OF KARAVAN TRAILERS, INC. ANY
REPRODUCTION IN PART OR WHOLE WITHOUT
THE WRITTEN PERMISSION OF KARAVAN TRAILERS,
INC. IS PROHIBITED.

APPROVED BY:

DRAWN BY:
JOEL NEHRING

DATE: 08-24-05

SHEET: 1 OF 1

SCALE: N/A

KARAVAN

TITLE: GUIDE ON BRACKET

MAT'L: 10 GA. SHEET

FINISH: -GL

DWG. #: 100-02554

DWG. REV.	ECR/NDR NUMBER	REVISED BY	DATE	DESCRIPTION
B	13430	CR	02-03-06	MADE ALL DIMS. 3 PLACE, ADDED (2) HOLES @ 3.406, 5.844 WAS 6.50, 5.407 WAS 6.07, R.125 - 4X WAS R.25 - 4X, 1.281 WAS 1.531.
A	13278	JRN	09-02-05	DRAWING CREATED

First Piece - In Process Inspection Sheet

Vendor _____

Description: **Guide On Bracket**

Part # **100-02554** Rev. **B**

QA Approval: S. Mudra

JOB# _____

Characteristic	Tol.	Method	Freq.	1st Piece	A/R	2	A/R	3	A/R	4	A/R	5	A/R	6	A/R	7	A/R	Inspected By/Date:
LASER																		
10 GA.	.126 - .142	Mic	1st Piece															1 /
H.R.P.O.	NA	Visual	1st Piece															2 /
5.000	±.030	Caliper	1st Piece															3 /
5.844	±.030	Caliper	1st Piece															4 /
Ø.5625 - 6X	±.010	Caliper	1st Piece															5 /
FORM																		
1.31	±.060	Caliper	1:100															6 /
1.188	±.030	Caliper	1:100															7 /
1.281	+ .060 - .000	Caliper	1:100															
R .125 - 4X	NA	Radius Gage	1st Piece															
Inspect parts for scratches, dents, gouges, etc.	NA	Visual	Every piece															
No slugs left in lasered holes.	NA	Visual	Every piece															