

ITEM NO.	PART NO.	DESCRIPTION	QTY.
1	100-00089	BACKING PLATE	2
2	100-00492	SPRING HANGER	2
3	100-00982	FENDER BRACKET R.H.	1
4	100-00983	FENDER BRACKET L.H.	1
5	221-00014		1

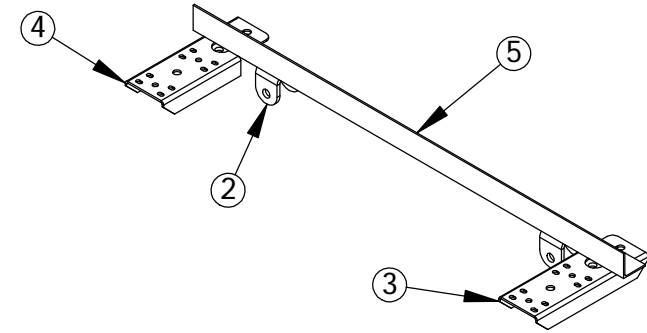

DETAIL A

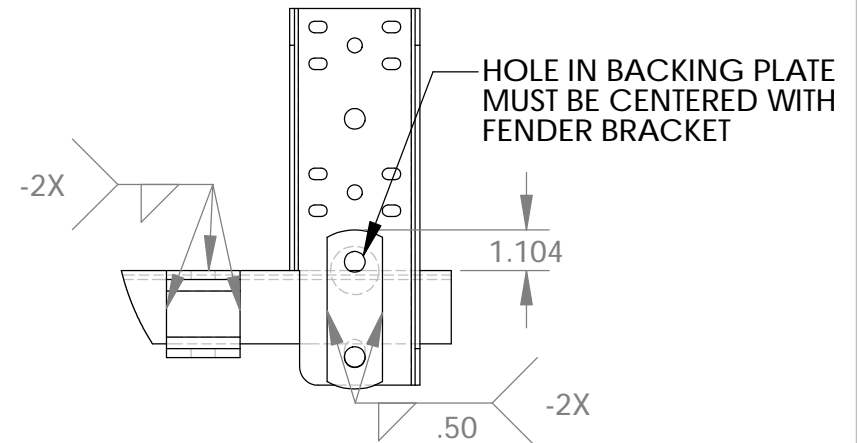

ALL DIMENSIONS ARE IN INCHES
UNLESS OTHERWISE STATED
TOLERANCES EXCEPT AS NOTED

DECIMALS:
.X ±0.100
.XX ±0.060
.XXX ±0.030
.XXXX ±0.010

ANGLES:
±1°

ALL FORMED ANGLES
EQUAL 90° UNLESS
NOTED OTHERWISE

() INDICATES REFERENCE

THE INFORMATION IN THIS DRAWING IS THE SOLE
PROPERTY OF KARAVAN TRAILERS, INC. ANY
REPRODUCTION IN PART OR WHOLE WITHOUT
THE WRITTEN PERMISSION OF KARAVAN TRAILERS,
INC. IS PROHIBITED

APPROVED BY:

DRAWN BY:

DATE: 10-27-97

SHEET: 1 OF 1

SCALE: N/A



TITLE: 14" FENDER WELDMENT

MAT'L: SEE B.O.M.

FINISH: -ZN

DWG. #: 300-01000

DWG. REV.	ECR/NDR NUMBER	REVISED BY	DATE	DESCRIPTION
E	12483	CR	09-10-03	ADDED 1.104 DIMENSION
D	12539	JRN	07-15-03	(39.75) WAS (40.00), 6.75 WAS 6.88, 2.63 WAS 2.75

OBSOLETE PER ECR#14157 ON 03-24-2008

First Piece - In Process Inspection Sheet

Vendor _____

Description: **14" Fender Weldment**

Part # **300-01000**

Rev. **E**

QA Approval: K. Baumhardt

JOB# _____

Characteristic	Tol.	Method	Freq.	1st Piece	A/R	2	A/R	3	A/R	4	A/R	5	A/R	6	A/R	Last piece	A/R	Inspected By:	
WELD																		1	/
26.250	+0.000 -0.060	Tape	2x per shift															2	/
6.75	± .060	Tape	2x per shift															3	/
34.500	±0.030	Tape	2x per shift															4	/
2.63	± .060	Tape	2x per shift															5	/
DETAIL A																		6	/
1.104	±0.030	Caliper	2x per shift															7	/
Hole in backing plate must be centered with fender bracket	NA	Visual	Every piece																
Weld per print	NA	Visual	Every piece																
Remove all visible weld splatter, every piece	NA	Visual	Document 4x per shift																