

FORM VIEW

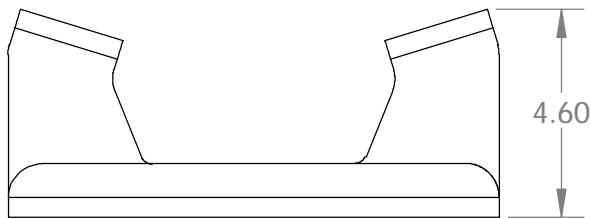
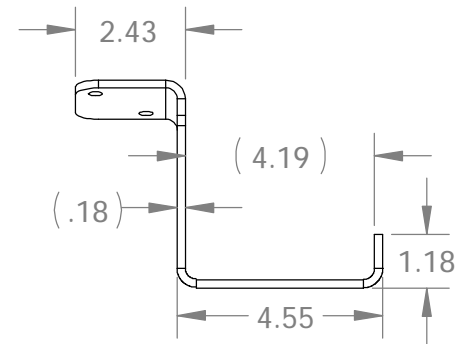

ALL DIMENSIONS ARE IN INCHES
UNLESS OTHERWISE STATED
TOLERANCES EXCEPT AS NOTED
DECIMALS:

.X ±0.100
.XX ±0.060
.XXX ±0.030
.XXXX ±0.010

ANGLES:
±1°

ALL FORMED ANGLES
EQUAL 90° UNLESS
NOTED OTHERWISE

() INDICATES REFERENCE

THE INFORMATION IN THIS DRAWING IS THE SOLE
PROPERTY OF KARAVAN TRAILERS, INC. ANY
REPRODUCTION IN PART OR WHOLE WITHOUT
THE WRITTEN PERMISSION OF KARAVAN TRAILERS,
INC. IS PROHIBITED.

APPROVED BY:

DRAWN BY:

JOEL NEHRING

DATE:

01-09-06

SHEET:

1 OF 1

SCALE:

N/A

KARAVAN

TITLE:

BUNK BRACKET

MAT'L:

7GA HRPO SHEET

FINISH:

-BL, -GL

DWG. #:

100-02586-D

DWG. REV.	ECR/NDR NUMBER	REVISED BY	DATE	DESCRIPTION
D	15417	LJW	11-29-11	10.875 OVERALL WIDTH WAS 11.50, 4.60 WAS 4.69, 2.43 WAS 2.69, ADDED .3125 HOLES (4X)
C	14658	JCR	06-18-08	CHANGED HOLE DIMENSION TO .4063

First Piece - In Process Inspection Sheet

Vendor _____

Description: **Bunk Bracket**

Part # **100-02586** Rev. **D**

QA Approval: K. Hopf

JOB# _____

Characteristic	Tol.	Method	Freq.	1st Piece	A/R	2	A/R	3	A/R	4	A/R	5	A/R	6	A/R	7	A/R	Inspected By/Date:
LASER																		
7 GA.	.171-.187	Mic.	1st/Last Piece															1 /
H.R.P.O.	NA	Visual	1st/Last Piece															2 /
11.561	±.030	Caliper	1st/Last Piece															3 /
10.875	±.030	Caliper	1st/Last Piece															4 /
Ø.3125 - 4X	±.010	Caliper	1st/Last Piece															5 /
Ø.5000 - 4X	±.010	Caliper	1st/Last Piece															6 /
Ø.5625 - 2X	±.010	Caliper	1st/Last Piece															7 /
FORM																		
2.43	± .060	Caliper	1:100															
1.18	± .060	Caliper	1:100															
4.55	± .060	Caliper	1:100															
4.60	± .060	Caliper	1:100															
Inspect parts for scratches, dents,	NA	Visual	Every piece															
No slugs left in lasered holes.	NA	Visual	Every piece															