

FORMED VIEWS

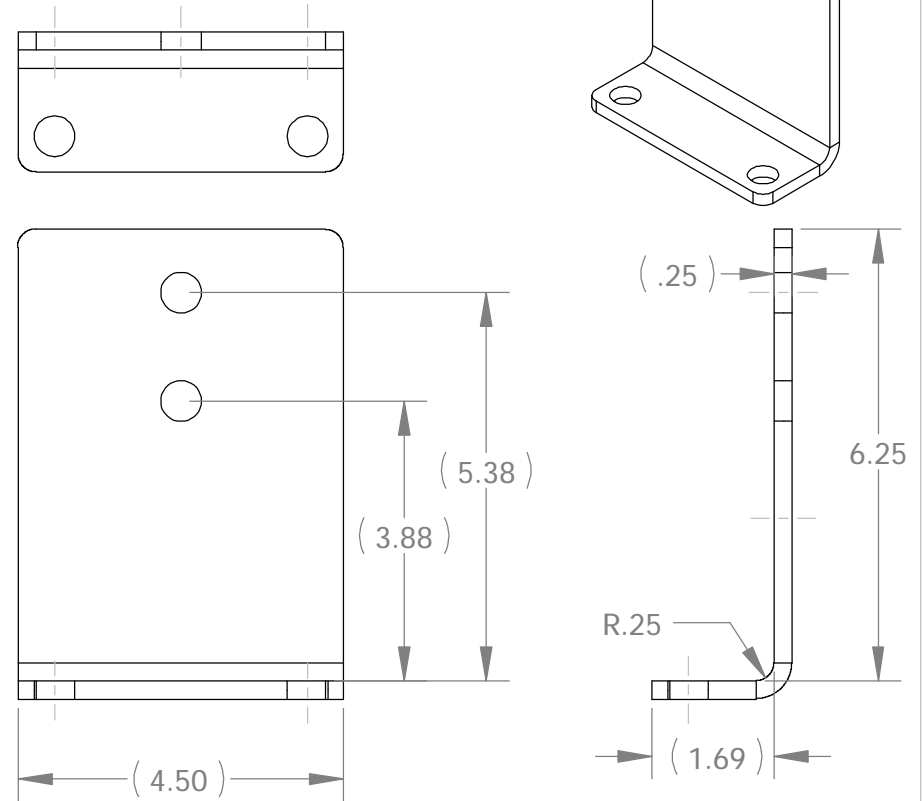

ALL DIMENSIONS ARE IN INCHES
UNLESS OTHERWISE STATED
TOLERANCES EXCEPT AS NOTED
DECIMALS:

.X ±0.100
.XX ±0.060
.XXX ±0.030
.XXXX ±0.010

ANGLES:
±1°

ALL FORMED ANGLES
EQUAL 90° UNLESS
NOTED OTHERWISE

() INDICATES REFERENCE

THE INFORMATION IN THIS DRAWING IS THE SOLE
PROPERTY OF KARAVAN TRAILERS, INC. ANY
REPRODUCTION IN PART OR WHOLE WITHOUT
THE WRITTEN PERMISSION OF KARAVAN TRAILERS,
INC. IS PROHIBITED.

APPROVED BY:

DRAWN BY:

KEVIN BLANK

DATE:

03-23-06

SHEET:

1 OF 1

SCALE:

N/A

KARAVAN

TITLE:

BUNK BRACKET

MAT'L:

.25" SHEET

FINISH:

-GL

DWG. #:

100-02678-A

DWG. REV.	ECR/NDR NUMBER	REVISED BY	DATE	DESCRIPTION
A	13455	KDB	03-23-06	DWG CREATED

First Piece - In Process Inspection Sheet

Vendor _____

Description: **Bunk Bracket**

Part # **100-02678**

Rev. **A**

QA Approval: K. Boomsma

JOB# _____

Characteristic	Tol.	Method	Freq.	1st Piece	A/R	2	A/R	3	A/R	4	A/R	5	A/R	6	A/R	7	A/R	Inspected By/Date:	
LASER																			
.25"	.242 - .258	Mic.	1 per bundle															1	/
8.000	± .030	Caliper	1st pc.															2	/
4.500	± .030	Caliper	1st pc.															3	/
Ø.5625 - 4X	± .010	Caliper	1st pc.															4	/
FORM																			
6.25	± .060	Caliper	1:50															5	/
R.25	NA	Radius Gauge	1st pc.															6	/
90°	± 1°	Protractor	1:50															7	/
Inspect parts for scratches, dents, gouges, etc.	NA	Visual	Every piece																
No slugs left in lasered holes.	NA	Visual	Every piece																