

ITEM NO.	PART NUMBER	DESCRIPTION	QTY.
1	210-00025	.375" FLAT WASHER	2
2	210-00076	.375"-16 CENTERLOCK HEX NUT	2
3	210-00172	.375"-16 X 3.75" HX HD BOLT	2
4	310-03900	BUNK ASSY	1

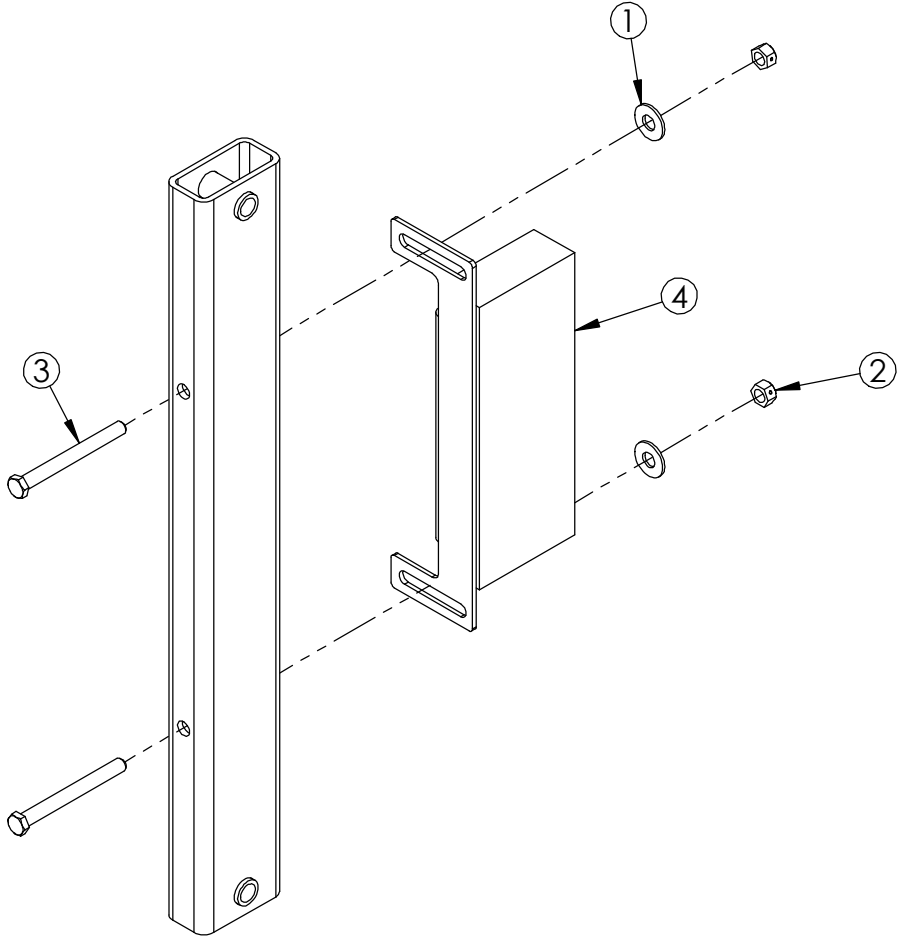

ALL DIMENSIONS ARE IN INCHES
UNLESS OTHERWISE STATED
TOLERANCES EXCEPT AS NOTED

DECIMALS:

.X ±0.100
.XX ±0.060
.XXX ±0.030
.XXXX ±0.010

ANGLES:

±1°

ALL FORMED ANGLES
EQUAL 90° UNLESS
NOTED OTHERWISE

() INDICATES REFERENCE

THE INFORMATION IN THIS DRAWING IS THE SOLE
PROPERTY OF KARAVAN TRAILERS, INC. ANY
REPRODUCTION IN PART OR WHOLE WITHOUT
THE WRITTEN PERMISSION OF KARAVAN TRAILERS,
INC. IS PROHIBITED.

APPROVED BY:

DRAWN BY:

TODD VAN HERWAARDEN

DATE:

02-07-18

SHEET:

1 OF 1

SCALE:

N/A

KARAVAN

TITLE:

PONTOON TRAVEL KIT (KPSHD)

MAT'L:

SEE B.O.M.

FINISH:

N/A

DWG. #:

320-03212-A

DWG. REV.	ECR/NDR NUMBER	REVISED BY	DATE	DESCRIPTION
A	15958	TVH	02-07-18	ASSEMBLY DRAWING CREATED