

ITEM NO.	PART NUMBER	DESCRIPTION	QTY
1	210-00015	.50"-13 X 6.00" HX HD BOLT	6
2	210-00061	.50"-13 CENTERLOCK HEX NUT	6
3	210-00240	.50" SAE FLAT WASHER ZINC	6
4	229-90239-MFG	TIE DOWN	6

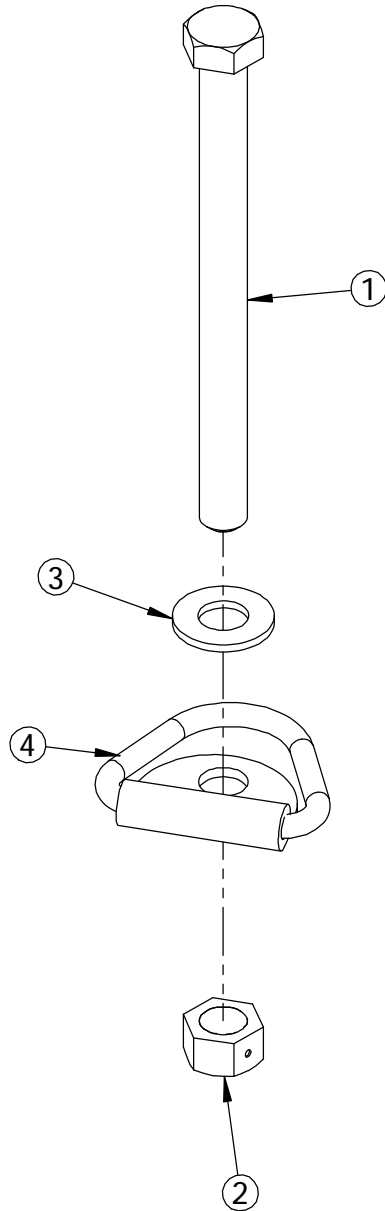

ALL DIMENSIONS ARE IN INCHES
UNLESS OTHERWISE STATED
TOLERANCES EXCEPT AS NOTED

DECIMALS:

.X ±0.100
.XX ±0.060
.XXX ±0.030
.XXXX ±0.010

ANGLES:
±1°

ALL FORMED ANGLES
EQUAL 90° UNLESS
NOTED OTHERWISE

() INDICATES REFERENCE

THE INFORMATION IN THIS DRAWING IS THE SOLE
PROPERTY OF KARAVAN TRAILERS, INC. ANY
REPRODUCTION IN PART OR WHOLE WITHOUT
THE WRITTEN PERMISSION OF KARAVAN TRAILERS,
INC. IS PROHIBITED.

APPROVED BY:

DRAWN BY:

TODD VAN HERWAARDEN

DATE:

03-19-15

SHEET:

1 OF 1

SCALE:

N/A

KARAVAN

TITLE:

TIE-DOWN KIT

MAT'L:

SEE B.O.M.

FINISH:

-NA

DWG. #:

320-03017-B

B	15770	JRS	11-14-17	229-90239 REPLACED 229-90228
A	15770	TVH	03-19-15	DRAWING CREATED
DWG. REV.	ECR/NDR NUMBER	REVISED BY	DATE	DESCRIPTION