

ITEM NO.	PART NUMBER	DESCRIPTION	QTY.
1	210-00025	.375" FLAT WASHER	4
2	210-00031	.375"-16 X 2.031" X 3.75" U-BOLT	2
3	210-00076	.375"-16 CENTERLOCK HEX NUT	4
4	310-02292	GUIDE-ON ASSY.	1

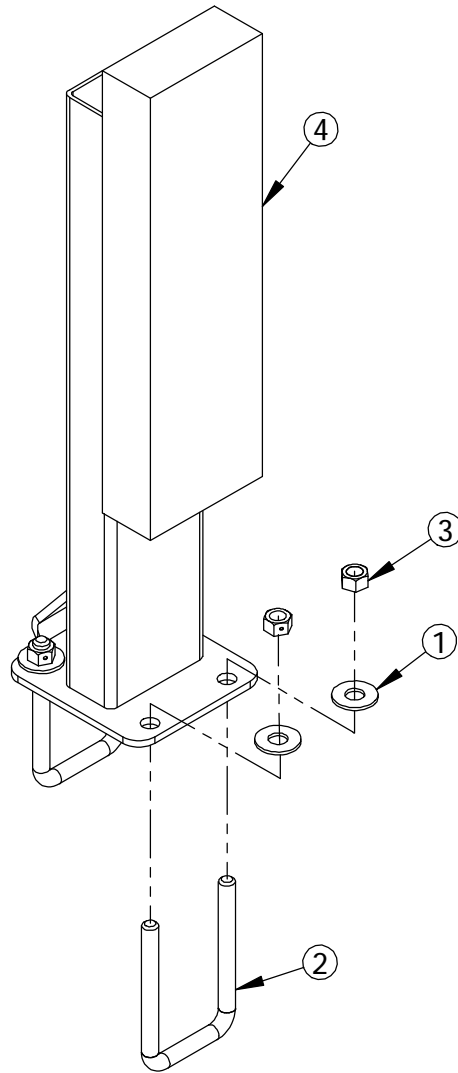

ALL DIMENSIONS ARE IN INCHES
UNLESS OTHERWISE STATED
TOLERANCES EXCEPT AS NOTED
DECIMALS:

.X ±0.100
.XX ±0.060
.XXX ±0.030
.XXXX ±0.010

ANGLES:
±1°

ALL FORMED ANGLES
EQUAL 90° UNLESS
NOTED OTHERWISE

() INDICATES REFERENCE

THE INFORMATION IN THIS DRAWING IS THE SOLE
PROPERTY OF KARAVAN TRAILERS, INC. ANY
REPRODUCTION IN PART OR WHOLE WITHOUT
THE WRITTEN PERMISSION OF KARAVAN TRAILERS,
INC. IS PROHIBITED.

APPROVED BY:

DRAWN BY:

NICK ARNDT

DATE:

05-26-06

SHEET:

1 OF 1

SCALE:

N/A

KARAVAN

TITLE:

GUIDE ON KIT

MAT'L:

SEE B.O.M.

FINISH:

@ASSEMBLY

DWG. #:

320-02095

DWG. REV.	ECR/NDR NUMBER	REVISED BY	DATE	DESCRIPTION
C	15036	KMH	04-19-11	210-00076 REPLACED 210-00048
B	14311	DLC	10-03-07	310-02292 WAS 310-01888