



*Doing Our Best to Provide You the Best*

BH20044, Rev 0  
06/21

---

## **BRAKE ACTUATOR DA70**

---

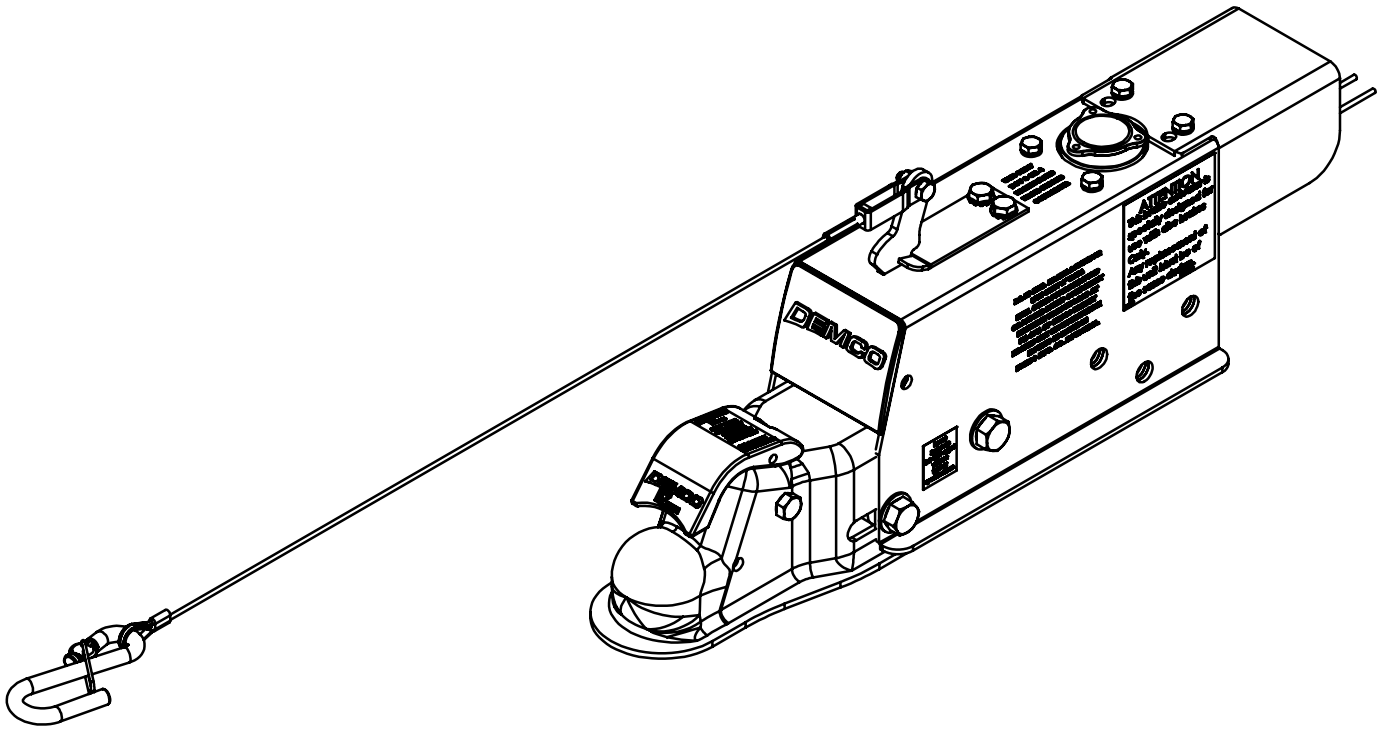

**OPERATOR MANUAL**

**Model DA70 is a hydraulic surge brake actuator for trailers with two or four wheels. When brakes are applied on the towing vehicle, forward inertia of trailer toward towing vehicle applies brakes on trailer in direct relation to manner brakes are applied on towing vehicle. Brake towing vehicle hard and brakes on trailer are applied hard. Master cylinder push rod spring assembly protects system from hydraulic pressure overload.**

### WARRANTY POLICY, OPERATOR MANUALS & REGISTRATION

Go online to [www.demco-products.com](http://www.demco-products.com) to review Demco warranty policies, operator manuals and register your Demco product.



### **WARNING: To Prevent Serious Injury or Death**

- **Review following instructions before installation and use of hydraulic brake actuator.**
- **Dealers or distributors must review these instructions with ultimate user.**
- **Failure to follow these instructions, or failure to properly maintain braking system after installation, can result in loss of braking action.**

### Table of Contents

General information.....	2
Safety, Signal Words .....	3
Equipment Safety Guidelines .....	3
Remember .....	3
Safety Sign Locations.....	4
Safety Sign Care .....	4
Before Operation .....	5
During Operation.....	5
Following Operation.....	6
Highway and Transport Operations.....	6
Performing Maintenance.....	6-7
Bolt Torque.....	7
DA70 Brake Actuator Parts Breakdown and Parts List .....	8
Repair Kit Parts List.....	9
Actuator Installation and Maintenance.....	10-11
Actuator Trouble Shooting Guide .....	11

**TAKE NOTE! THIS SAFETY ALERT SYMBOL FOUND THROUGHOUT THIS MANUAL IS USED TO CALL YOUR ATTENTION TO INSTRUCTIONS INVOLVING YOUR PERSONAL SAFETY AND SAFETY OF OTHERS. FAILURE TO FOLLOW THESE INSTRUCTIONS CAN RESULT IN INJURY OR DEATH.**



**THIS SYMBOL MEANS  
ATTENTION  
BECOME ALERT  
YOUR SAFETY IS INVOLVED!**

### **SIGNAL WORDS**

Note use following signal words **DANGER, WARNING, and CAUTION** with safety messages. Appropriate signal word for each has been selected using following guidelines:

#### **DANGER:**

Indicates an imminently hazardous situation that, if not avoided, will result in serious injury or death. This signal word is to be limited to most extreme situations typically for machine components which, for functional purposes, cannot be guarded.

If you have questions not answered in this manual, require additional copies, or if your manual is damaged, please contact your dealer or Demco, P.O. Box 189, 4010 320th Street, Boyden, IA 51234

ph: (712) 725-2311 Toll Free: 1-800-543-3626 Fax: (712) 725-2380 <http://www.demco-products.com>

#### **WARNING:**

Indicates a potentially hazardous situation that, if not avoided, could result in serious injury or death, and includes hazards that are exposed when guards are removed. It may also be used to alert against unsafe practices.

#### **CAUTION:**

Indicates a potentially hazardous situation that, if not avoided, may result in minor or moderate injury. It may also be used to alert against unsafe practices.



### **EQUIPMENT SAFETY GUIDELINES**

Every year many accidents occur which could have been avoided by a few seconds of thought and a more careful approach to handling equipment. You the operator, can avoid many accidents by observing and following precautions in this section. To avoid personal injury, study the following precautions and insist those working with you, or you yourself, follow them.

In order to provide a better view, certain illustrations in this manual may show an assembly with a safety shield removed. However, equipment should never be operated in this condition. Keep all shields in place. If shield removal becomes necessary for repairs, replace shield prior to use.

Replace any caution, warning, danger or instruction safety decal that is not readable or is missing. Location of such decals is indicated in this booklet.

Do not attempt to operate this equipment under the influence of alcohol or drugs.

Review safety instructions with all users.

Operator should be a responsible adult. **DO NOT ALLOW PERSONS TO OPERATE OR ASSEMBLE THIS UNIT UNTIL THEY HAVE DEVELOPED A THOROUGH UNDERSTANDING OF SAFETY PRECAUTIONS AND HOW IT WORKS.**

Do not paint over, remove, or deface any safety signs or warning decals on your equipment. Observe all safety signs and practice instructions on them.

Never exceed limits of a piece of machinery. If its ability to do a job, or to do so safely is in question-**DON'T TRY IT.**



### **REMEMBER**

Your best assurance against accidents is a careful and responsible operator. If there is any portion of this manual or function you do not understand, contact your local authorized dealer or manufacturer.



## SAFETY SIGN LOCATIONS

Types of safety sign and locations on equipment are shown in illustration below. Good safety requires that you familiarize yourself with various safety signs, type of warning, and area or particular function related to that area, that requires your SAFETY AWARENESS.

### DRUM BRAKES

**Preset Fasteners DO NOT adjust without factory specifications.**

This decal is located in the position shown on both sides of the actuator. The replacement part number for two decals is BH21004.

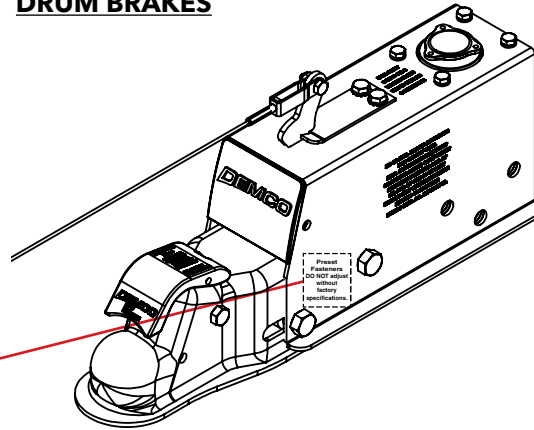

### DISC BRAKES

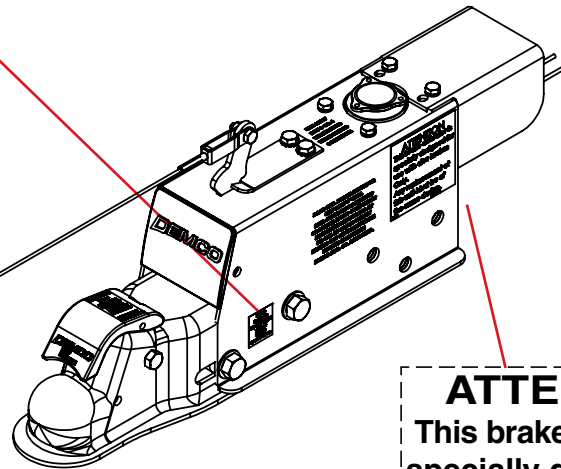

This decal is located in the position shown on both sides of the actuator. The replacement part number for one decal is BD21001.

**ATTENTION**  
**This brake actuator is specially designed for use with disc brakes ONLY.**  
**Any replacement of this unit MUST be of the same design.**

REV 1  
BD21001



## SAFETY SIGN CARE

- Keep safety signs clean and legible at all times.
- Replace safety signs that are missing or have become illegible.
- Replacement parts that displayed a safety sign should also display safety sign.
- Safety signs are available from your distributor, dealer parts department, or factory.

### **How to install safety signs:**

- Be sure that installation area is clean and dry.
- Decide on exact position before you remove backing paper.
- Remove smallest portion of split backing paper.
- Align decal over specified area and carefully press small portion with exposed sticky backing in place.
- Slowly peel back remaining paper and carefully smooth remaining portion of decal into place.
- Small air pockets can be pierced with a pin and smoothed out using piece of decal backing paper.



### **BEFORE OPERATION:**

- Carefully study and understand this manual.
- Always wear protective clothing and substantial shoes.
- Give equipment a visual inspection for any loose bolts, worn parts, or cracked welds, and make necessary repairs. Follow maintenance safety instructions included in this manual.
- Be sure there are no tools lying on or in equipment.
- Do not use equipment until you are sure that area is clear, especially around children and animals.
- Don't hurry learning process or take equipment for granted. Ease into it and become familiar with your new equipment.
- Practice operation of your equipment and its attachments. Completely familiarize yourself and other operators with its operation before using.
- Make sure that brakes are evenly adjusted.
- Make sure tow rating on vehicle is high enough for what it is towing.
- Do not allow anyone to stand between tongue or hitch and towing vehicle when backing up to equipment.
- Securely attach to towing vehicle. Use appropriately sized hitch ball and/or hitch pin with a mechanical retainer and attach safety chains.
- Criss cross chains under tongue and secure to draw bar cage, mounting loops, or bumper frame.



### **DURING OPERATION**

- **SAFETY CHAINS** If equipment is going to be transported on a public highway, safety chains should be obtained and installed. Always follow state and local regulations regarding safety chains and auxiliary lighting when towing equipment on a public highway. Be sure to check with local law enforcement agencies for your own particular regulations. Only safety chains (not an elastic or nylon/plastic tow straps) should be used to retain connection between towing and towed equipment in event of separation of primary attaching system.
- Install safety chains by criss crossing chains under tongue and secure to draw bar cage, mounting loops, or bumper frame.
- **When attaching the emergency cable Allow adequate slack to keep from activating brakes due to interference from parts of the coupler or other attachments on the towing vehicle. Each vehicle tongue configuration is different and therefore each should be handled individually to keep the routing free from entanglements and securely attached to perform as designed in case of emergency disconnection from the towing vehicle.**
- Beware of bystanders, **PARTICULARLY CHILDREN!** Always look around to make sure it is safe to start engine of towing vehicle or move equipment. This is particularly important with higher noise levels, as you may not hear people shouting.
- **NO PASSENGERS ALLOWED-** Do not carry passengers anywhere on or in equipment.
- Do not clean, lubricate, or adjust your equipment while it is moving.
- When halting operation, even periodically, set towing vehicles parking brake, shut off engine, and **remove the ignition key.**
- Be extra careful when using on inclines.
- **MANEUVER TOWING UNIT AT SAFE SPEEDS.**
- Avoid loose gravel, rocks, and holes, they can be dangerous for equipment operation or movement.
- Allow for overall length when making turns.
- Keep all bystanders and pets clear of work area.
- Operate towing vehicle from operators seat only.
- Never leave running equipment attachments unattended.
- As a precaution, always recheck hardware on equipment following every 100 hours or 50 miles. Correct all problems. Follow maintenance safety procedures.



### **FOLLOWING OPERATION**

- Following operation, or when unhitching, stop towing vehicle, set brakes, shut off the engine and **remove ignition key**.
- Store unit in an area away from human activity.
- Do not permit children to play on or around stored unit.
- Make sure all parked units are on a hard, level surface and engage all safety devices.
- Wheel chocks may be needed to prevent unit from rolling.



### **HIGHWAY AND TRANSPORT OPERATIONS**

- Adopt safe driving practices:
  - Always drive at a safe speed relative to local conditions and ensure that your speed is low enough for an emergency stop.
  - Reduce speed prior to turns to avoid risk of overturning.
  - Always keep towing vehicle in gear to provide engine braking when going downhill. Do not coast.
  - Do not drink and drive!
- Comply with state and local laws governing highway safety on public roads.
- Use approved accessory lighting, flags and necessary warning devices to protect operators of other vehicles on highway during transport. Various safety lights and devices are available from your dealer.
- Local laws should be checked for all highway lighting and marking requirements.
- Plan your route to avoid heavy traffic.
- Be a safe and courteous driver. Always yield to oncoming traffic in all situations, including narrow bridges, intersections, etc.
- Be observant of bridge loading ratings. Do not cross bridges rated lower than the gross weight at which you are operating.
- Watch for obstructions overhead and side to side while transporting.
- Always operate equipment in a position to provide maximum visibility at all times. Make allowances for increased length and weight of equipment when making turns and/or stopping.



### **PERFORMING MAINTENANCE**

- Good maintenance is your responsibility. Poor maintenance is an invitation to trouble.
- Make sure there is plenty of ventilation. Never operate engine of towing vehicle in a closed building. Exhaust fumes may cause asphyxiation.
- Before working on this unit, stop towing vehicle, set parking brakes, shut off engine and **remove ignition key**.
- Be certain all moving parts and attachments have come to a complete stop before attempting to perform maintenance.
- Always use safety supports and block wheels. Never use a jack to support unit.

- Always use proper tools or equipment for job at hand.
- Use extreme caution when making adjustments.
- Follow torque chart in this manual when tightening bolts and nuts.
- Openings in skin and minor cuts are susceptible to infection from brake fluid.  
**Without immediate medical treatment, serious infection and reactions can occur.**
- Replace **all shields** and **guards** after servicing and before moving.
- After servicing, be sure all tools, parts and service equipment are removed.
- Do not allow grease or oil to build up on the actuator.
- When replacing bolts, refer to owners manual.
- Refer to bolt torque chart for head identification marking.
- Where replacement parts are necessary for periodic maintenance and servicing, genuine factory replacement parts must be used to restore your equipment to original specifications. Manufacturer will not claim responsibility for use of unapproved parts or accessories and other damages as a result of their use.
- If equipment has been altered in any way from original design, manufacturer does not accept any liability for injury or warranty.
- A fire extinguisher and first aid kit should be kept readily accessible while performing maintenance on this equipment



**Torque Specifications**

Tighten all bolts to torques specified in chart unless otherwise noted. Check tightness of bolts periodically, using bolt chart as guide. Replace hardware with same grade bolt.

NOTE: Unless otherwise specified, high-strength Grade 5 hex bolts are used throughout assembly of equipment.

Torque figures indicated are valid for non-greased or non-oiled threads and heads unless otherwise specified. Therefore, do not grease or oil bolts or capscrews unless otherwise specified in this manual. When using locking elements, increase torque values by 5%.

\* GRADE or CLASS value for bolts and capscrews are identified by their head markings.

**Bolt Torque for Standard bolts \***

"A"	GRADE 2		GRADE 5		GRADE 8	
	lb-ft	(N.m)	lb-ft	(N.m)	lb-ft	(N.m)
1/4"	6	(8)	9	(12)	12	(16)
5/16"	10	(13)	18	(25)	25	(35)
3/8"	20	(27)	30	(40)	45	(60)
7/16"	30	(40)	50	(70)	80	(110)
1/2"	45	(60)	75	(100)	115	(155)
9/16"	70	(95)	115	(155)	165	(220)
5/8"	95	(130)	150	(200)	225	(300)
3/4"	165	(225)	290	(390)	400	(540)
7/8"	170	(230)	420	(570)	650	(880)
1"	225	(300)	630	(850)	970	(1310)

**Bolt Torque for Metric bolts \***

"A"	CLASS 8.8		CLASS 9.8		CLASS 10.9	
	lb-ft	(N.m)	lb-ft	(N.m)	lb-ft	(N.m)
6	9	(13)	10	(14)	13	(17)
7	15	(21)	18	(24)	21	(29)
8	23	(31)	25	(34)	31	(42)
10	45	(61)	50	(68)	61	(83)
12	78	(106)	88	(118)	106	(144)
14	125	(169)	140	(189)	170	(230)
16	194	(263)	216	(293)	263	(357)
18	268	(363)	--	--	364	(493)
20	378	(513)	--	--	515	(689)
22	516	(699)	--	--	702	(952)
24	654	(886)	--	--	890	(1206)

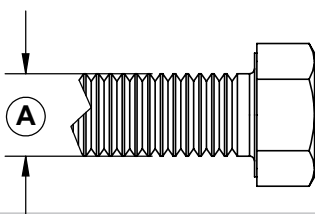

**GRADE-2**

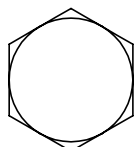

**GRADE-5**

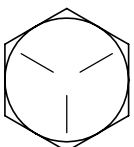

**GRADE-8**

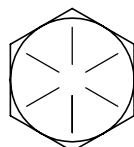

**CLASS 8.8**

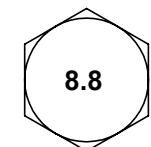

**CLASS 9.8**

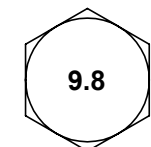

**CLASS 10.9**



# PARTS BREAKDOWN

## 8705001 DRUM BRAKE 8705101 DISC BRAKE

Do not tighten these bolts. They are factory torqued and must remain loose enough to allow free coupler movement.

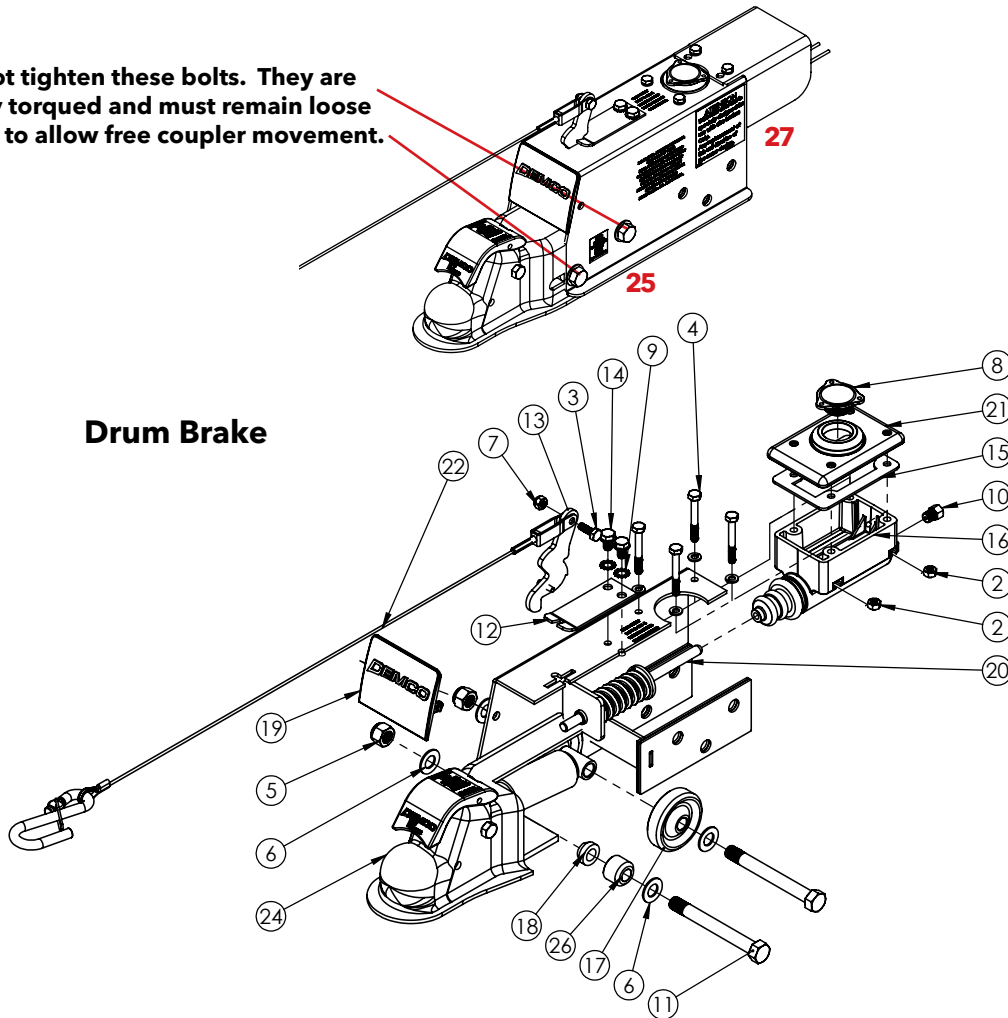

**Drum Brake**

**Disc Brake**

REF NO.	PART NO.	QTY	DESCRIPTION
1	00057	4	WASHER 1/4" SPRING LOCK
2	00062	4	NUT .25NC HEX
3	00068	1	HBOLT .2500-20
4	00618	4	1/4"NC X 2.00 HEX HEAD BOLT GR.5
5	02178	2	NUT 1/2"NC LOCK NYLON INSERT
6	02384	4	1/2" X 14GA MACHINE WASHER
7	02772	1	NUT 1/4" LOCK NYLON INSERT
8	03876	1	MASTER CYLINDER CAP ASSEMBLY
9	05424	2	WASHER 5/16" EXTERNAL TOOTH LOCK
10	05679	1	BRAKE FITTING .125 FULL FLOW <b>DRUM</b>
11	05684	2	1/2"-13UNC SPECIAL HEX BOLT
12	05693-95	1	SPRING SAFETY LEVER
13	05951	1	EMERGENCY LEVER
14	05960	2	BOLT 5/16" X 1/2" HEX WASHER HD SELF TAPPING
15	09153	1	CORK GASKET F/ MASTER CYLINDER
16	10616	1	MASTER CYLINDER <b>DRUM</b>
-	35693	1	MASTER CYLINDER PREASSY <b>DISC</b>
17	12103	2	BACK ROLLER
18	12151	2	ROLLER SPACER

Please order replacement parts by PART NO. & DESCRIPTION

REF NO.	PART NO.	QTY	DESCRIPTION
19	12187	1	DEMCO LOGO FRONT COVER
20	12193	1	PUSHROD ASSY
21	12557	1	CAP F/ MASTER CYLINDER
22	14091	1	SAFETY CABLE ASSY
23	17236-95	1	DA70 OUTER CASE
24	35906	1	7000# 2" COUPLER W/ SHOCK
25	BH21004	2	DECAL
26	SB23278	2	ROLLER
27	BD21001	2	DECAL
28	12267-95	1	SOLENOID COVER <b>DISC</b>

Please order replacement parts by PART NO. & DESCRIPTION

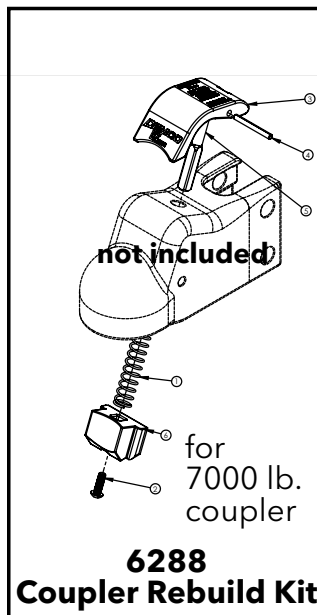
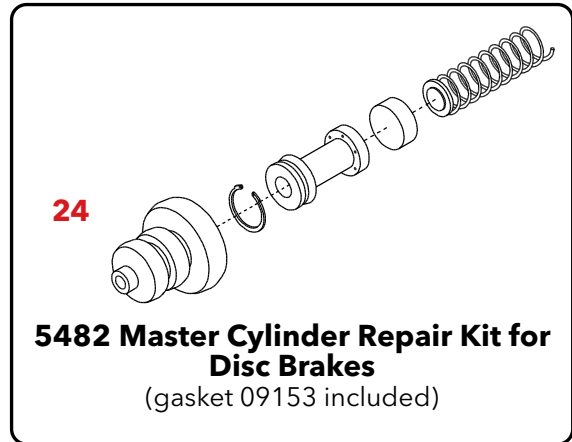
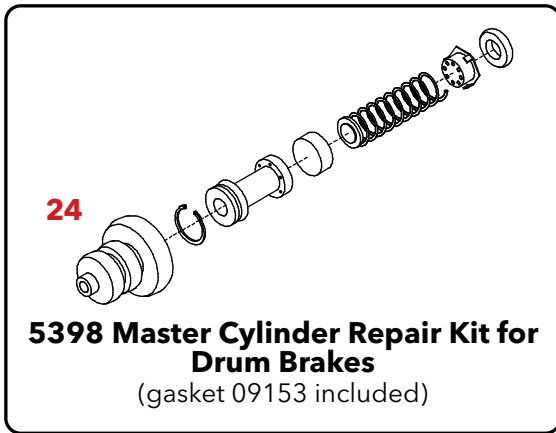

REF NO.	PART NO.	QTY	DESCRIPTION
-	<b>5398</b>	-	Master Cylinder Repair Kit w/gasket
-	<b>5400</b>	-	Emergency Lever Replace Kit ( incl. 05951 & 05693)
-	<b>5482</b>	-	Master Cylinder Repair Kit w/gasket
-	<b>6288</b>	-	Coupler Rebuild Kit (ez-latch)
<b>Please order replacement parts by PART NO. &amp; DESCRIPTION</b>			

### DEMCO MODEL DA70 BRAKE ACTUATOR



#### **WARNING To Prevent Serious Injury Or Death:**

- Review all of the following instructions before installation and use of hydraulic brake actuator.
- Dealers or Distributors must review these instructions with ultimate user.
- Failure to follow these instructions, or failure to properly maintain braking system after installation, can result in loss of braking action which could cause severe property damage, personal injury or death.



#### **WARNING**

**To avoid personal injury or death, do not exceed lowest of (1) the rated capacity of Model DA70 actuator, or (2) rated capacity of ball and hitch being used, or (3) trailer's Gross Vehicle Weight Rating (GVWR).**

**Model DA70 brake actuator has a maximum load rating of 6000 lbs. GVWR and 600 lbs. tongue load.**



#### **CAUTION**

**To avoid personal injury or death Do not weld on the outer case without disassembling actuator. The excessive heat may cause the actuator not to function properly**

SPECIAL NOTE - WHEN PRESSURE BLEEDING BRAKES IT IS STILL NECESSARY TO SHORT STROKE THE MASTER CYLINDER SEVERAL TIMES TO ELIMINATE TRAPPED AIR BUBBLES.

#### **Elevate tongue on trailer 4-6 inches**

Refer to actuator parts breakdown page to locate referenced part numbers associated with procedures below: Visually inspect actuator to ensure the inner coupler (#1) is fully extended.

#### **\*Failure to perform this function will prevent proper and complete bleeding of system\***

- Loosen or remove two 5/16" bolts (#14) that hold the lever guide and flat emergency lever spring (#12). Remove master cylinder fill cap (#8).
- Using short strokes, pull forward on emergency lever (#13), pumping master cylinder until brake fluid in master cylinder reservoir (#16) stops bubbling.
- Attach a bleeder hose to a bleeder valve on one of the wheels (starting at wheel farthest from master cylinder) and submerge other end into a transparent container partially filled with brake fluid to prevent possible splashing from container.
- Loosen bleeder valve one turn and while watching fluid in container, use emergency lever (#13) to pump fluid as long as bubbles continue to leave submerged hose. When bubbles stop, close bleeder valve, move to next wheel and repeat until all brakes are bled. (Note: Check master cylinder often (every 4-5 strokes) and refill above half full as needed )
- Refill master cylinder and securely attach cap (#8). Reinstall emergency lever spring, lever guide, lock washers and 5/16" hex head bolts. When tightening the bolts, make sure the lever moves freely in the groove in the guide.

Test brakes by pulling emergency lever (#13) forward until it locks into position. Lever will be pointing approximately straight up. Attempt to rotate wheels in a forward direction. If any wheel rotates, brakes assemblies must be adjusted.

Jack up trailer and secure on adequate capacity jack stands. Follow trailer manufacturer's recommendations for lifting and supporting the unit. Make sure the wheel and drum rotates freely.

Remove the adjusting hole cover from the adjusting slot on the bottom of the brake backing plate.

With a screwdriver or standard adjusting tool, rotate the star wheel of the adjuster assembly to expand the brake shoes. Adjust the brake shoes out until the pressure of the linings against the drum makes the wheel very difficult to turn in forward direction.

Back off the adjuster wheel 15-20 clicks. The wheel should turn freely with a possible, slight lining drag.

Replace the adjusting hole cover and lower the wheel to the ground. Repeat the above procedure on all brakes. For best results, the brakes should all be set at the same clearance.

**\*Retest the brakes by locking the emergency lever on and attempt to rotate tires in a forward direction, if any wheel turns there might be trapped air in the system yet.**

**SERVICING THE EMERGENCY LEVER**

If emergency lever (#11) of actuator is applied, it can be disengaged by using a screwdriver to lift upward on front of flat emergency lever spring (#16) while pulling lever forward until released. A thorough inspection of emergency lever, emergency lever spring, and safety cable is required. Damaged parts must be replaced as follows:

- A. Remove Cable (#13) from emergency lever (#11) and flat emergency lever spring (#16), then pull lever out of actuator outer case (#20) through cross-slot in top.
- B. Install new emergency lever through cross-slot in top of outer case. Attach new emergency lever spring.
- C. Bolt emergency cable to emergency lever using bolt & locknut, leave loose to allow fork to pivot on lever.
- D. Add adequate brake fluid to master cylinder and bleed brake system per instructions 4-6 in installation section.

**Actuator Trouble Shooting Guide**

**Symptoms**

**Possible Solutions**

**Brakes Locking Up**

Emergency lever partially pulled

- Release emergency lever.  
(Lever must be in green zone).  
(Emergency cable must have slack)
- Clean/flush or replace orifice
- Clean/flush or replace master cylinder
- Replace brake line or hose.  
Inspect wheel cylinder for rust and proper function
- Check for broken springs  
Check shoe adjustment (too tight)  
Cluster mounting bracket bent  
Trailer must be level or parallel with ground

Debris in master cylinder orifice  
Debris/rust in master cylinder  
Pinched brake line or hose  
Brake cluster hanging up

**Master Cylinder Not Priming**

Master cylinder lever will not pump fluid

- Slide tube must be completely extended
- Check fluid level.  
Clean/flush or replace master cylinder  
Clean/flush or replace orifice  
Inspect line/hoses for blockages.
- Check all line connections for air leaks
- Check fluid level and bleed brakes

Master cylinder orifice plugged  
Brake fluid does not come out of orifice  
Brake fluid does not come out of brake line  
Air in brake lines

**Leaking Master Cylinder**

Brake fluid leaking out of push rod area  
Brake fluid leaks out of gasket area

- Repair or replace master cylinder.  
Damaged gasket. Replace gasket.
- Tighten master cylinder bolts in an alternating sequence  
(10 inch lbs. torque)  
Master cylinder tightened unevenly.
- Replace gasket and tighten bolts alternating sequence.  
Do not overfill master cylinder  
When attaching main brake line to orifice, use line wrench and back-up wrench to prevent over-tightening or damage to threads in master cylinder.

Brake fluid leaks out of gasket area

Brake fluid leaks around orifice

**Brake Testing**

Jack trailer wheels up off ground.  
Spin wheel/wheels. Wheels should spin freely.  
Pull emergency lever on as far forward as possible, wheels should not turn by hand. Release emergency lever.  
Wheels should spin forward without resistance.

# **DEMCO**

4010 320th St., Boyden, IA. 51234

Phone: (712) 725-2311

Fax: (712) 725-2380

Toll Free: 1-800-54DEMCO (1-800-543-3626)

**Demco warranty policies, operator manuals, and product registration  
can be found online:**

**[www.demco-products.com](http://www.demco-products.com)**

